

# SP500 AC Drive

Version 3.1



## Important User Information

Solid-state equipment has operational characteristics differing from those of electromechanical equipment. Safety Guidelines for the Application, Installation and Maintenance of Solid State Controls (publication [SGI-1.1](#) available from your local Rockwell Automation sales office or online at <http://www.rockwellautomation.com/literature/>) describes some important differences between solid-state equipment and hard-wired electromechanical devices. Because of this difference, and also because of the wide variety of uses for solid-state equipment, all persons responsible for applying this equipment must satisfy themselves that each intended application of this equipment is acceptable.

In no event will Rockwell Automation, Inc. be responsible or liable for indirect or consequential damages resulting from the use or application of this equipment.

The examples and diagrams in this manual are included solely for illustrative purposes. Because of the many variables and requirements associated with any particular installation, Rockwell Automation, Inc. cannot assume responsibility or liability for actual use based on the examples and diagrams.

No patent liability is assumed by Rockwell Automation, Inc. with respect to use of information, circuits, equipment, or software described in this manual.

Reproduction of the contents of this manual, in whole or in part, without written permission of Rockwell Automation, Inc., is prohibited.

Throughout this manual, when necessary, we use notes to make you aware of safety considerations.



**WARNING:** Identifies information about practices or circumstances that can cause an explosion in a hazardous environment, which may lead to personal injury or death, property damage, or economic loss.



**ATTENTION:** Identifies information about practices or circumstances that can lead to personal injury or death, property damage, or economic loss. Attentions help you identify a hazard, avoid a hazard, and recognize the consequence.



**SHOCK HAZARD:** Labels may be on or inside the equipment, for example, a drive or motor, to alert people that dangerous voltage may be present.



**BURN HAZARD:** Labels may be on or inside the equipment, for example, a drive or motor, to alert people that surfaces may reach dangerous temperatures.



**ARC FLASH HAZARD:** Labels may be on or inside the equipment, for example, a motor control center, to alert people to potential Arc Flash. Arc Flash will cause severe injury or death. Wear proper Personal Protective Equipment (PPE). Follow ALL Regulatory requirements for safe work practices and for Personal Protective Equipment (PPE).

---

### IMPORTANT

Identifies information that is critical for successful application and understanding of the product.

---

## Document Update

### **Electronic Motor Overload Protection**

This product does not offer speed-sensitive overload protection, thermal memory retention or provisions to act upon motor over-temperature sensing in motors. If such protection is needed in the end-use product, it needs to be provided by additional means.

**Notes:**

## Summary of Changes

---

The information below summarizes the changes made to this manual since its last release (July 1999).

Description of Changes	Page
Added Document Update.	After manual front cover

**Notes:**

# CONTENTS

---

<b>Chapter 1</b>	<b>Introduction</b>	
1.1	Who Should Use This Manual .....	1-1
1.2	Installation Overview .....	1-1
1.3	Requesting Assistance from Reliance Electric .....	1-1
<b>Chapter 2</b>	<b>Learning About the SP500 Drive</b>	
2.1	Standard Features .....	2-1
2.2	Drive Description .....	2-2
2.3	Identifying the Drive by Model Number .....	2-6
	2.3.1 Power Ratings and NEMA Enclosure Ratings .....	2-7
	2.3.2 Enclosure Ratings and Sizes .....	2-8
2.4	Component Locations.....	2-8
2.5	Option Kits .....	2-13
<b>Chapter 3</b>	<b>SP500 System Planning</b>	
3.1	Installation Site Requirements .....	3-1
	3.1.1 Determining the Total Area Required for Installation .....	3-2
	3.1.2 Providing Proper Air Flow Clearances .....	3-4
	3.1.3 Verifying the Drive's Power Loss Rating .....	3-4
3.2	Wiring Requirements .....	3-4
	3.2.1 Verifying Conduit Sizes .....	3-4
	3.2.2 Recommended Power Wire Sizes.....	3-4
	3.2.3 Recommended Control and Signal Wire Sizes .....	3-6
	3.2.4 Recommended Motor Lead Lengths .....	3-6
3.3	Selecting Input AC Line Branch Circuit Fuses.....	3-8
3.4	Installing an Emergency Stop.....	3-9
	3.4.1 Complying with Machinery Safety Standard EN 60204-1:1992 .....	3-9
3.5	Motor Considerations .....	3-9
	3.5.1 Single-Motor Applications.....	3-9
	3.5.2 Multiple-Motor Applications .....	3-10
<b>Chapter 4</b>	<b>Installing the Drive</b>	
4.1	Mounting the Drive .....	4-1
4.2	Routing Wires .....	4-1
4.3	Installing External Components .....	4-6
	4.3.1 Disconnects.....	4-6
	4.3.2 Input AC Line Branch Protection .....	4-6
	4.3.3 Transformers .....	4-6
	4.3.4 Output Contactors .....	4-7
	4.3.5 Mechanical Motor Overload Protection .....	4-7
4.4	Setting the Analog Input Jumper on the Regulator Board .....	4-7
4.5	Preparing the Motor .....	4-8

<b>Chapter 5</b>	<b>Wiring the Drive</b>	
5.1	Input Power Wiring.....	5-1
5.2	Signal and Control Wiring .....	5-3
5.2.1	Analog Speed Reference Wiring .....	5-3
5.2.2	Analog Output Wiring.....	5-4
5.2.3	Digital Input Wiring.....	5-4
5.2.4	Snubber Resistor Wiring.....	5-8
5.2.5	Output Status Relay Wiring .....	5-10
5.3	Output Power Wiring .....	5-10
5.4	Grounding .....	5-11
<b>Chapter 6</b>	<b>Completing the Installation</b>	
6.1	Checking the Installation With the Power Off.....	6-1
6.2	Checking Drive Operation .....	6-2
<b>Chapter 7</b>	<b>Keypad and Display Operation</b>	
7.1	Display Description .....	7-1
7.2	Key Descriptions .....	7-2
7.3	LED Descriptions .....	7-3
7.4	Program Mode .....	7-4
7.5	Monitor Mode .....	7-5
7.5.1	Displaying the Percent Selected Speed Reference.....	7-6
7.5.2	Scaling the RPM Display and Reference Using F-08 .....	7-6
7.6	Drive Control .....	7-6
7.6.1	Changing the Reference Using the Keypad .....	7-7
<b>Chapter 8</b>	<b>Programming Reference</b>	
8.1	Displaying or Changing Parameter Values .....	8-1
8.2	Ensuring Program Security .....	8-3
8.3	Parameter Descriptions.....	8-5
<b>Chapter 9</b>	<b>Troubleshooting Reference</b>	
9.1	Verifying DC Bus Voltage.....	9-1
9.2	Troubleshooting the Drive Using Fault Codes .....	9-3
9.3	Accessing and Clearing the Error Log .....	9-5
9.4	Checking the Drive's Power Module Circuitry with the Power Off.....	9-7
<b>Appendix A</b>	<b>Technical Specifications.....</b>	<b>A-1</b>
<b>Appendix B</b>	<b>Record of User Settings .....</b>	<b>B-1</b>
<b>Appendix C</b>	<b>Alphabetical Listing of Parameters.....</b>	<b>C-1</b>
<b>Appendix D</b>	<b>Compliance with Machinery Safety Standard EN-60204-1:1992 .....</b>	<b>D-1</b>
<b>Appendix E</b>	<b>Compliance with Electromagnetic Compatibility Standards .....</b>	<b>E-1</b>
<b>Appendix F</b>	<b>Replacement Parts.....</b>	<b>F-1</b>
<b>Glossary</b>	.....	<b>Glossary-1</b>
<b>Index</b>	.....	<b>Index-1</b>



# List of Figures

Figure 2.1 – SP500 System Diagram .....	2-3
Figure 2.2 – SP500 System Diagram (Continued) .....	2-4
Figure 2.3 – Regulator Board Component Locations .....	2-5
Figure 2.4 – Identifying the Drive Model Number .....	2-6
Figure 2.5 – Enclosure A Component Locations .....	2-9
Figure 2.6 – Enclosure B Component Locations .....	2-10
Figure 2.7 – Enclosure C Component Locations .....	2-11
Figure 2.8 – Enclosure D Component Locations .....	2-12
Figure 3.1 – Enclosure A Dimensions .....	3-2
Figure 3.2 – Enclosure B Dimensions .....	3-2
Figure 3.3 – Enclosure C Dimensions .....	3-3
Figure 3.4 – Enclosure D Dimensions .....	3-3
Figure 3.5 – How to Measure Motor Lead Lengths .....	3-6
Figure 4.1 – Enclosure A Wire Routing Locations .....	4-2
Figure 4.2 – Enclosure B Wire Routing Locations .....	4-3
Figure 4.3 – Enclosure C Wire Routing Locations .....	4-4
Figure 4.4 – Enclosure D Wire Routing Locations .....	4-5
Figure 4.5 – Jumper J6 Settings for the Analog Input Speed Reference .....	4-8
Figure 5.1 – Typical Electrical Connections.....	5-2
Figure 5.2 – Typical Control Terminal Strip Connections .....	5-3
Figure 5.3 – Analog Speed Reference Wiring Connections .....	5-4
Figure 5.4 – Analog Output Wiring Connections .....	5-4
Figure 5.5 – Two-Wire Start/Stop Sample Control Wiring .....	5-5
Figure 5.6 – Three-Wire Start/Stop Sample Control Wiring.....	5-5
Figure 5.7 – Multi-Speed Preset Sample Control Wiring .....	5-6
Figure 5.8 – Terminal Usage During Multi-Speed Preset Operation .....	5-7
Figure 5.9 – Snubber Resistor Wiring Connections for M/N 1SU2xxxx Drives .....	5-9
Figure 5.10 – Snubber Resistor Wiring Connections for M/N 1SU4xxxx and 1SU5xxxx Drives .....	5-9
Figure 5.11 – Output Status Relay Wiring Connections .....	5-10
Figure 7.1 – SP500 Keypad and Display .....	7-1
Figure 7.2 – SP500 Menu Structure .....	7-4
Figure 7.3 – Example of a Program Mode Display .....	7-5
Figure 7.4 – Example of a Monitor Mode Display .....	7-6
Figure 8.1 – Manual Torque Boost Adjustment Range.....	8-7
Figure 8.2 – Volts/Hertz Curve .....	8-8
Figure 9.1 – DC Bus Terminals on Model 1SU1xxxx and 1SU2xxxx Drives .....	9-2
Figure 9.2 – DC Bus Terminals on Model 1SU4xxxx and 1SU5xxxx Drives (except 1SU4x015, 1SU4x020).....	9-2
Figure 9.3 – DC Bus Terminals on Model 1SU4x015 and 1SU4x020 Drives.....	9-2



## List of Tables

Table 2.1 – SP500 Model Number Notation .....	2-6
Table 2.2 – Power and NEMA Enclosure Ratings .....	2-7
Table 2.3 – SP500 Option Kits .....	2-13
Table 3.1 – Air Flow Clearances.....	3-4
Table 3.2 – Recommended Power Wire Sizes for M/N 1SU1xxxx and 1SU2xxxx Drives.....	3-5
Table 3.3 – Recommended Power Wire Sizes for M/N 1SU4xxxx and 1SU5xxxx Drives.....	3-5
Table 3.4 – Recommended Power Wire Sizes for M/N 1SU4x015 and 1SU4x020 Drives .....	3-5
Table 3.5 – Recommended Power Terminal Tightening Torque .....	3-5
Table 3.6 – Recommended Control and Signal Wire Sizes and Tightening Torque	3-6
Table 3.7 – Motor Lead Lengths.....	3-7
Table 3.8 – Reactors .....	3-7
Table 3.9 – AC Input Line Fuse Selection Values .....	3-8
Table 7.1 – Key Descriptions.....	7-2
Table 7.2 – Drive Status LED Descriptions .....	7-3
Table 7.3 – Monitor Mode LED Descriptions .....	7-3
Table 8.1 – Multi-Speed Presets Digital Inputs.....	8-15
Table 8.2 – Auto-Restartable Faults .....	8-16
Table 9.1 – Drive Faults and Corrective Actions .....	9-3
Table 9.2 – Resistance Checks for Input Diodes.....	9-8
Table 9.3 – Resistance Checks for IGBTs.....	9-8



This chapter describes the manual's intended audience and provides an overview of the SP500 drive's installation process.

### 1.1 Who Should Use This Manual

This manual is intended for qualified electrical personnel responsible for installing, programming, starting up, and maintaining the SP500 drive.

### 1.2 Installation Overview

This manual describes how to install and troubleshoot the SP500 drive. Drive installation consists of the following basic tasks:

- Plan your installation using the guidelines presented in chapter 3. If your installation must be in compliance with Electromagnetic Compatibility Standards, read Appendix E also.
- Mount the drive and install external components according to the guidelines presented in chapter 4.
- Wire the drive's input power, output power, and control signal terminal strip using the instructions in chapter 5.
- Adjust parameter values, if required. The parameters are described in chapter 8. For quick reference, the factory-set values are listed in Appendix B.
- Perform the power-off and power-on checks described in chapter 6 to complete the installation.

If problems occur during drive operation, refer to chapter 9. Appendix F lists the parts of the drive that can be replaced.

Before you begin the installation procedure, become familiar with the drive by reading chapter 2, which provides an overview of the drive and its features, chapter 7, which describes the operation of the keypad and the display, and Appendix A, which lists the drive's technical specifications.

### 1.3 Requesting Assistance from Reliance Electric

If you have any questions or problems with the products described in this instruction manual, contact your local Reliance Electric sales office. For technical assistance, call 1-800-726-8112, Monday through Friday, 8:00 AM to 5:00 PM (EST).



---

## Learning About the SP500 Drive

This chapter describes the SP500 drive and how to identify it based on its model number. This chapter also provides power and enclosure rating information.

### 2.1 Standard Features

The SP500 drive has the following features:

- On-board keypad and display providing:
  - Start/Stop/Reset control
  - Forward/Reverse (reverse-disable selectable)
  - Setpoint adjustment
  - Motor RPM, %load, or output voltage display
  - Drive diagnostics
- 500 millisecond power dip ride-through
- 150% overload for one minute (nominal)
- 0.5 to 240 Hz three-phase voltage output
- NEMA 1 and NEMA 4/12 enclosures
- A snubber resistor braking signal and a scaled voltage analog output (0 to 10 VDC) which is proportional to:
  - Output frequency
  - Output amps
  - Output voltage
  - Selected reference
- Quiet motor operation with high carrier frequency selection
- Drive protection
  - Overcurrent
  - Short circuit
  - Ground fault
  - Overvoltage
  - Undervoltage
  - Overtemperature
- UL/CSA electronic overload that meets NEC/CEC requirements

- User-selectable relay contact for indications of drive running, drive faulted, or drive at selected speed
- User-selectable power-up start, auto-restart, and coast-to-rest or ramp-to-rest stop functions
- User-selectable local or remote operation
- 29 user-adjustable software parameters

## 2.2 Drive Description

The SP500 drive is an AC PWM (pulse-width-modulated) inverter that operates on single- or three-phase power. See figures 2.1 and 2.2. AC input power is applied to the drive's input terminals. Voltage transients are suppressed by three metal-oxide-varistor (MOV) suppressors. These suppressors keep any input voltage transients within the maximum voltage rating of the input diode module.

The input diode module rectifies the incoming AC voltage into a constant DC bus voltage which is filtered by the DC bus capacitor bank. An internal DC-to-DC power supply uses power from the DC bus and provides the necessary voltages required by the drive. Under regulator software control, the IGBT (insulated-gate bipolar-transistor) inverter bridge converts the constant DC voltage into an AC PWM waveform. The regulator switches the IGBT inverter bridge using a 4, 6, or 8 kHz carrier frequency (user-selectable). A low carrier frequency maximizes the power rating of the drive but also increases acoustic noise. A high carrier frequency selection reduces acoustic noise but results in a derating of the drive's efficiency.

The volts per hertz (V/Hz) regulator governs the open-loop operation of the drive for adjustable-speed performance of AC induction and synchronous motors. The regulator maintains a ratio of voltage to output frequency that provides constant or variable torque across a wide speed range. Drive operation can be adjusted by the parameters entered through the keypad. A microprocessor on the Regulator board controls drive regulation. See figure 2.3. The Regulator board accepts internal power feedback signals and an external speed reference signal. The Regulator board provides display data for a four-character display, which is used to indicate drive parameters, parameter values, and fault codes.

The drive can be controlled either locally through the keyboard and display (see section 7) or remotely through the terminal strip (see section 5).

The drive is intended to operate trip-free under any condition. The drive uses selected signals to extend the acceleration (starting) and deceleration (stopping) rates of the motor when an overcurrent condition occurs. When a fault does occur, however, the regulator generates an instantaneous electronic trip (IET) signal to turn the drive off (coast-to-rest). The drive stores an indication or record of the IET fault, which can be viewed on the four-character display. After a fault, the STOP/RESET key or a user-supplied IET RESET pushbutton must be pressed to reset the IET signal and clear the fault from the drive.



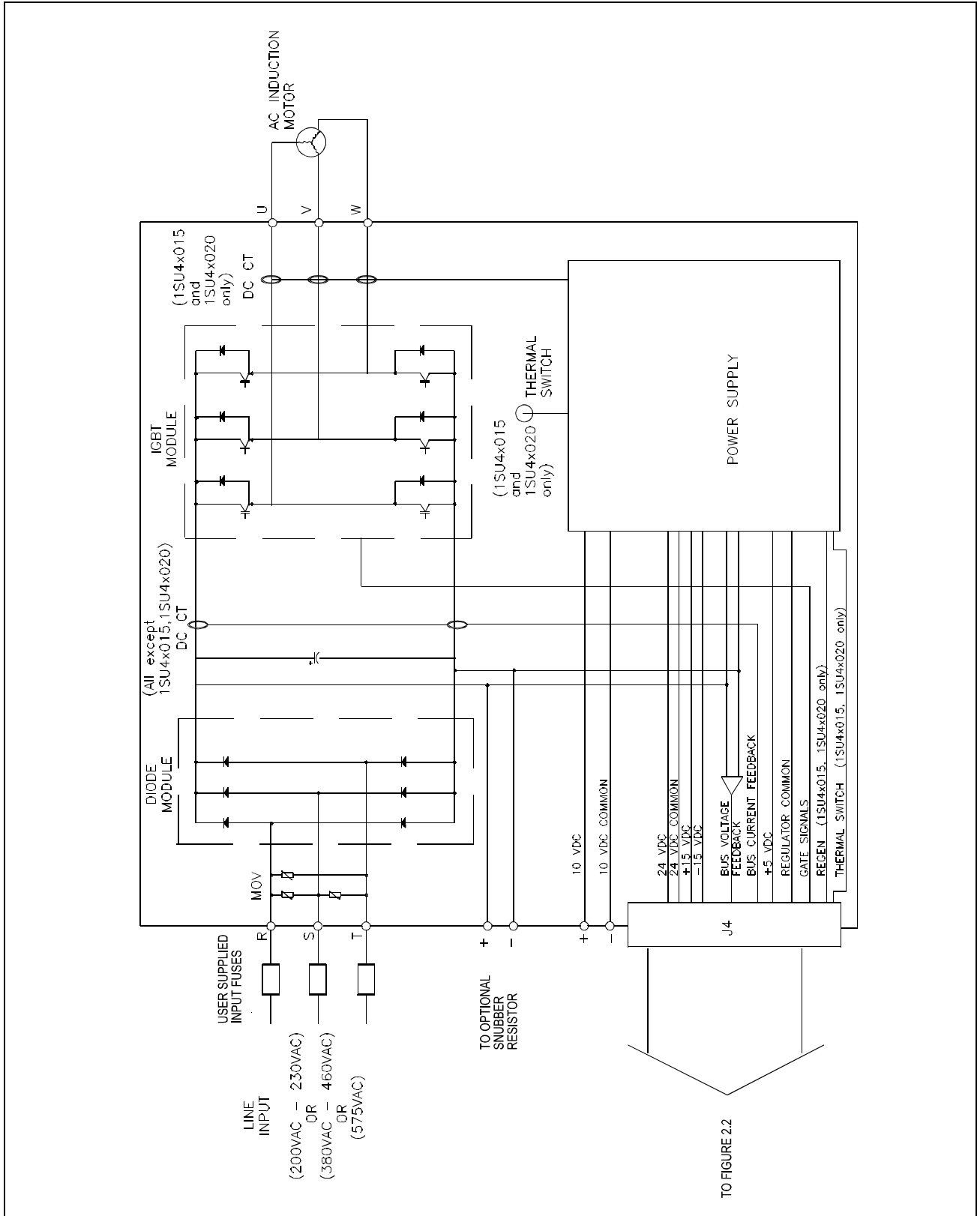

Figure 2.1 – SP500 System Diagram

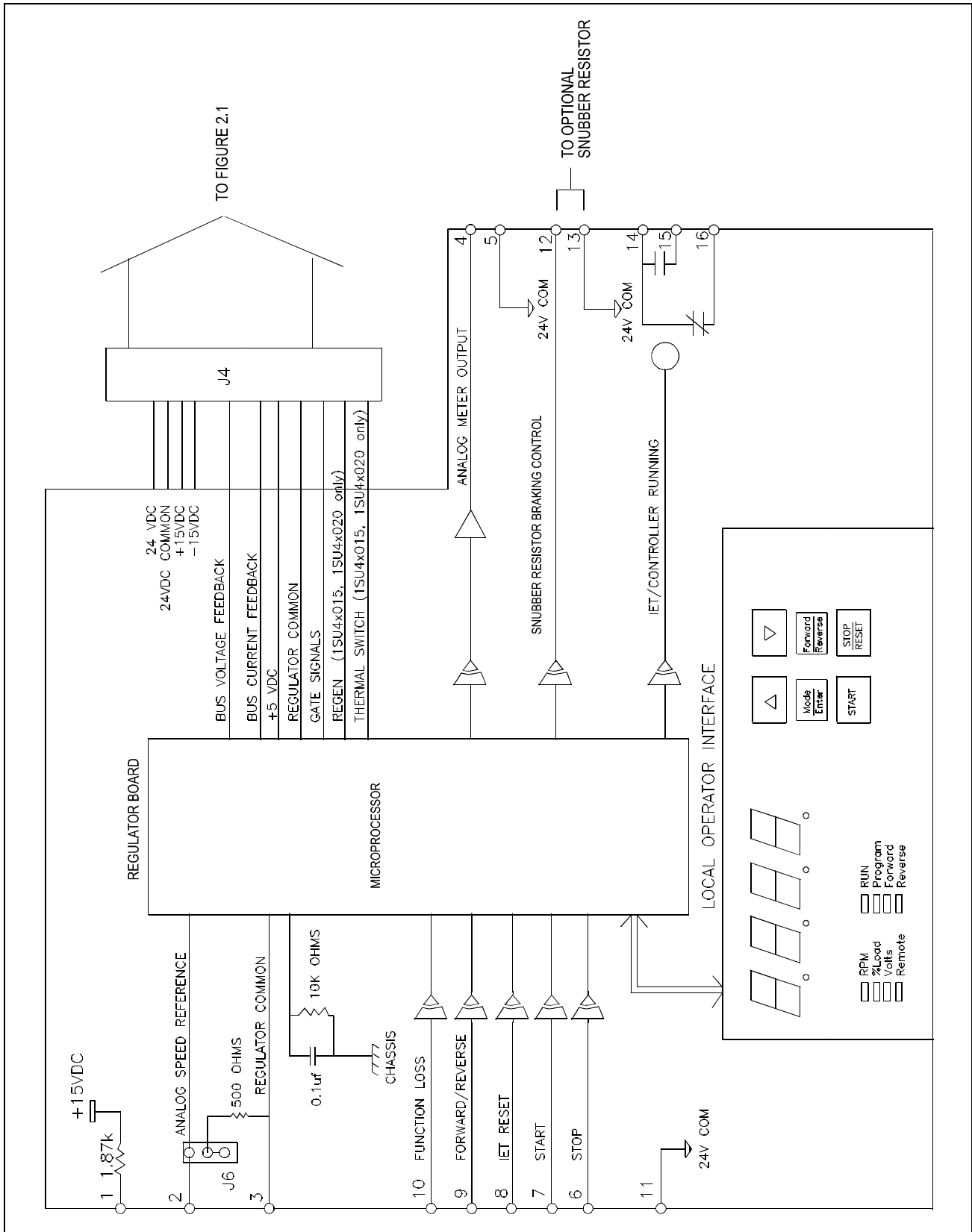

Figure 2.2 – SP500 System Diagram (Continued)

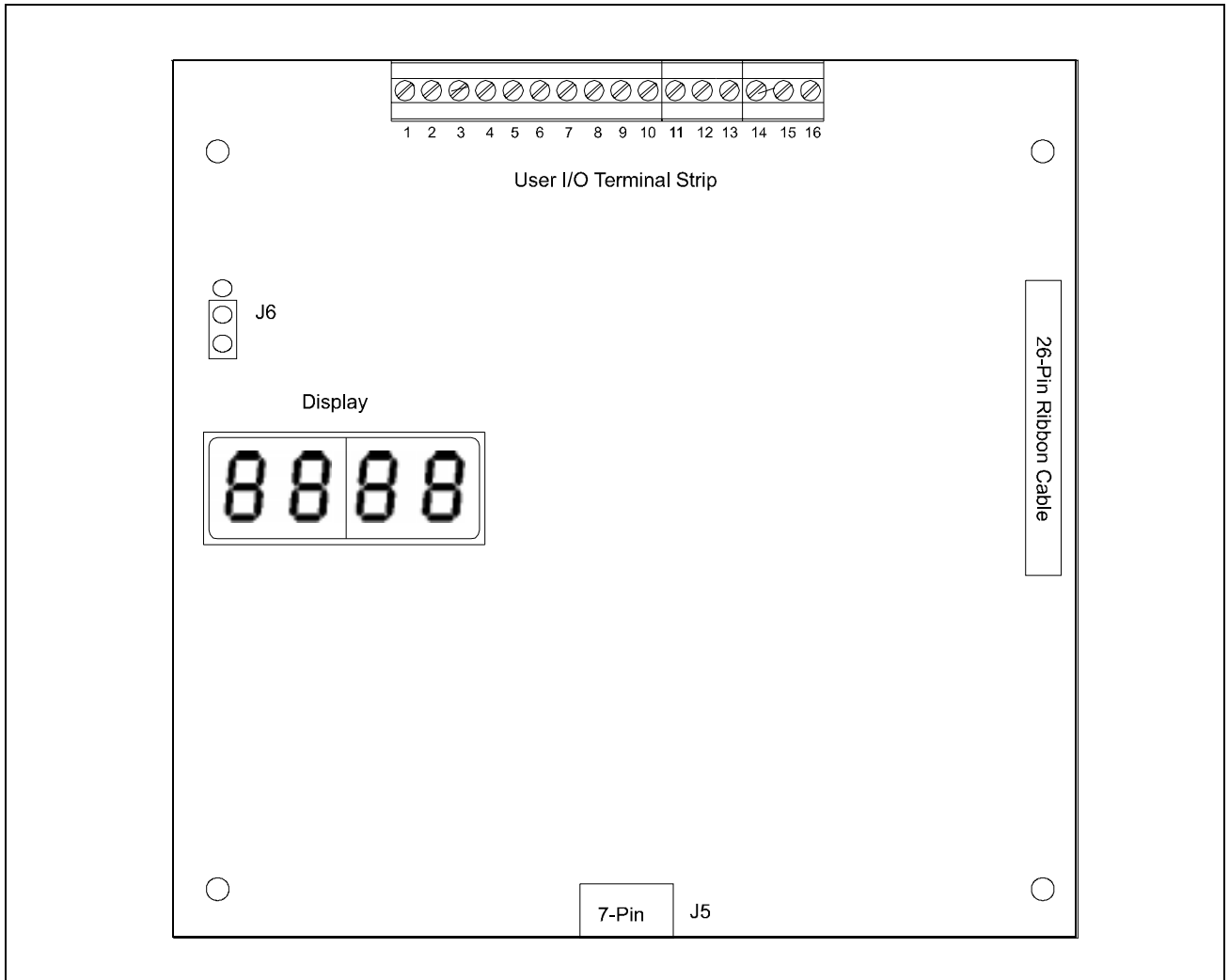

Figure 2.3 – Regulator Board Component Locations

## 2.3 Identifying the Drive by Model Number

A model number identifies each SP500 AC drive. See figure 2.4. This number appears on the shipping label and on the drive's nameplate located on the right side of the drive housing. The drive's model number contains codes that indicate: input voltage range, enclosure rating, and horsepower rating. See section 2.3.1 for more information on the drive power ratings. See section 2.3.2 for more information on the drive enclosure ratings.

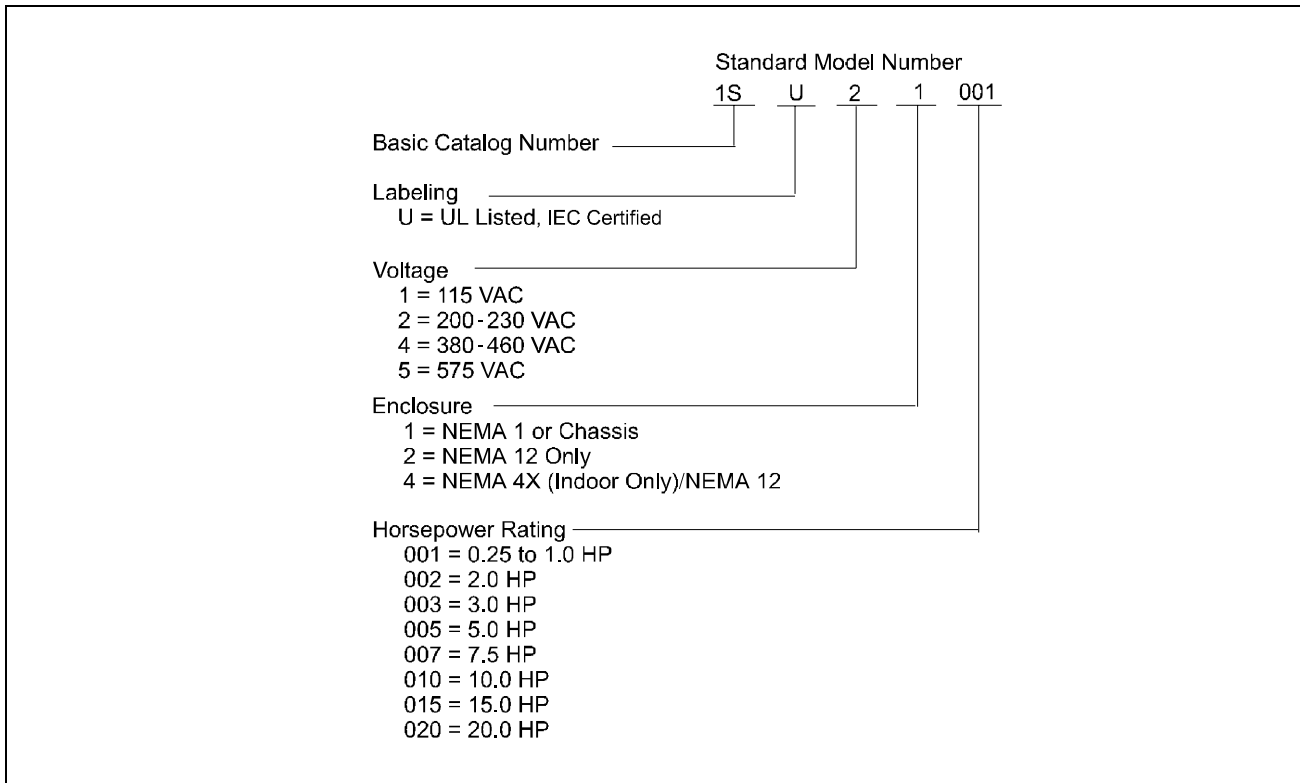

Figure 2.4 – Identifying the Drive Model Number

All SP500 drives described in this instruction manual function in the same manner. To identify the mechanical differences between certain models, the manual uses the notation in table 2.1.

Table 2.1 – SP500 Model Number Notation

Model Notation	Input Voltage	Horsepower
1SU1xxxx	115 VAC	¼ - 1 HP
1SU2xxxx	208 - 230 VAC	1, 2, 3, 5, 7.5, 10 HP
1SU4xxxx	380 - 460 VAC	1, 2, 3, 5, 7.5, 10, 15, 20 HP
1SU5xxxx	575 VAC	1, 2, 3, 5, 7.5, 10 HP

## 2.3.1 Power Ratings and NEMA Enclosure Ratings

Table 2.2 provides SP500 drive power and NEMA enclosure ratings.

Table 2.2 – Power and NEMA Enclosure Ratings

Model Number	Input Power and Horsepower Rating*	NEMA Rating	Enclosure Size**	AC Input Volts	Input Amps	Input KVA	Output Amps*	Power Loss Watts***
1SU11001	Single-Phase - 1 HP	1	A	115	13.1	1.5	6.8	80
1SU14001	Single-Phase - Demo	----	----	115	5.2	0.6	2.0	80
1SU21001	Single-Phase - 1 HP	1	A	200-230	5.0	1.3	1.7	70
1SU24001	Single-Phase - 1 HP	4X/12	A	200-230	5.0	1.3	1.7	70
1SU21002	Single-Phase - 2 HP 4 kHz Carrier 6 kHz Carrier 8 kHz Carrier	1	A	200-230	19.1	4.4	7.5	120
				200-230	17.2	4.0	7.0	120
				200-230	15.3	3.5	6.5	120
1SU21001	Three-Phase - 1 HP	1	A	200-230	7.0	2.8	5.0	70
1SU24001	Three-Phase - 1 HP 4 kHz Carrier 6 kHz Carrier 8 kHz Carrier	4X/12	A	200-230	6.4	2.6	4.5	70
				200-230	5.2	2.0	3.6	70
				200-230	5.2	2.0	3.6	70
1SU21002	Three-Phase - 2 HP 4 kHz Carrier 6 kHz Carrier 8 kHz Carrier	1	A	200-230	9.9	4.0	7.5	70
				200-230	9.3	3.8	7.0	70
				200-230	8.7	3.5	6.5	70
1SU24002	Three-Phase - 2 HP	4X/12	C	200-230	9.9	4.0	7.5	120
1SU21003	Three-Phase - 3 HP	1	C	200-230	12.5	5.0	10.6	210
1SU24003	Three-Phase - 3 HP	4X/12	C	200-230	12.5	5.0	10.6	210
1SU21005	Three-Phase - 5 HP	1	C	200-230	17.2	6.9	14.2	250
1SU24005	Three-Phase - 5 HP	4X/12	C	200-230	17.2	6.9	14.2	250
1SU41001	Three-Phase - 1 HP	1	B	380-460	2.5	2.0	2.1	60
1SU44001	Three-Phase - 1 HP	4X/12	B	380-460	2.5	2.0	2.1	60
1SU41002	Three-Phase - 2 HP	1	B	380-460	4.2	3.3	3.4	100
1SU44002	Three-Phase - 2 HP	4X/12	B	380-460	4.2	3.3	3.4	100
1SU41003	Three-Phase - 3 HP	1	B	380-460	6.4	5.1	5.3	140
1SU44003	Three-Phase - 3 HP	4X/12	B	380-460	6.4	5.1	5.3	140
1SU41005	Three-Phase - 5 HP	1	B	380-460	9.9	8.0	8.2	180
1SU44005	Three-Phase - 5 HP	4X/12	B	380-460	9.9	8.0	8.2	180
1SU41007	Three-Phase - 7.5 HP	1	C	380-460	13.4	10.7	11.1	210
1SU44007	Three-Phase - 7.5 HP	4X/12	C	380-460	13.4	10.7	11.1	210
1SU41010	Three-Phase - 10 HP	1	C	380-460	17.2	13.7	14.2	250
1SU44010	Three-Phase - 10 HP	4X/12	C	380-460	17.2	13.7	14.2	250
1SU41015	Three-Phase - 15 HP	1	D	380-460	25.4	20.2	21.0	375
1SU42015	Three-Phase - 15 HP	12	D	380-460	25.4	20.2	21.0	375
1SU41020	Three-Phase - 20 HP	1	D	380-460	32.7	26.1	27.0	600
1SU42020	Three-Phase - 20 HP	12	D	380-460	32.7	26.1	27.0	600
1SU51001	Three-Phase - 1 HP	1	B	575	2.0	2.0	1.6	50
1SU54001	Three-Phase - 1 HP	4X/12	B	575	2.0	2.0	1.6	50

Table 2.2 - Power and NEMA Enclosure Ratings (Continued)

Model Number	Input Power and Horsepower Rating*	NEMA Rating	Enclosure Size**	AC Input Volts	Input Amps	Input KVA	Output Amps*	Power Loss Watts***
1SU51002	Three-Phase - 2 HP	1	B	575	3.4	3.3	2.7	90
1SU54002	Three-Phase - 2 HP	4X/12	B	575	3.4	3.3	2.7	90
1SU51003	Three-Phase - 3 HP	1	B	575	5.2	5.1	4.3	120
1SU54003	Three-Phase - 3 HP	4X/12	B	575	5.2	5.1	4.3	120
1SU51005	Three-Phase - 5 HP	1	B	575	7.5	7.5	6.2	150
1SU54005	Three-Phase - 5 HP	4X/12	B	575	7.5	7.5	6.2	150
1SU51007	Three-Phase - 7.5 HP	1	C	575	10.9	10.9	9.0	180
1SU54007	Three-Phase - 7.5 HP	4X/12	C	575	10.9	10.9	9.0	180
1SU51010	Three-Phase - 10 HP	1	C	575	14.5	14.4	12.0	250
1SU54010	Three-Phase - 10 HP	4X/12	C	575	14.5	14.4	12.0	250

\* To properly size the drive for motor nameplate horsepower and amps, refer to section 3.5 for more information. Derating for 4, 6, 8kHz carrier frequencies is not required except for the units indicated.

\*\* Refer to section 2.3.2 for more information on enclosure sizes.

\*\*\* Full-load at all carrier frequencies. Refer to section 3.1.3 for more information.

## 2.3.2 Enclosure Ratings and Sizes

Each of the SP500 drives have one of the following NEMA ratings:

NEMA Rating	Description
1	Vented. For general-purpose indoor applications.
4X/12	Not vented. Supplied with base and keypad gaskets. For use in indoor environments that require a water-tight and dust-tight enclosure. An enclosure with this NEMA rating encompasses both ratings (4X and 12).
12	Intended for use in indoor environments that require a dust-tight and drip-tight enclosure.

See table 2.2 for a listing of drive model numbers and their individual NEMA ratings.

For clarity in this manual, SP500 drive enclosures are identified by size as enclosures A through D. Refer to table 2.2 for a listing of the drive model numbers and their individual enclosure sizes. Refer to section 3.1.1 for the dimensions of enclosures A through D.

## 2.4 Component Locations

Figures 2.5 through 2.8 show the main components of the SP500 drives (enclosures A through D). Appendix F lists replacement parts.

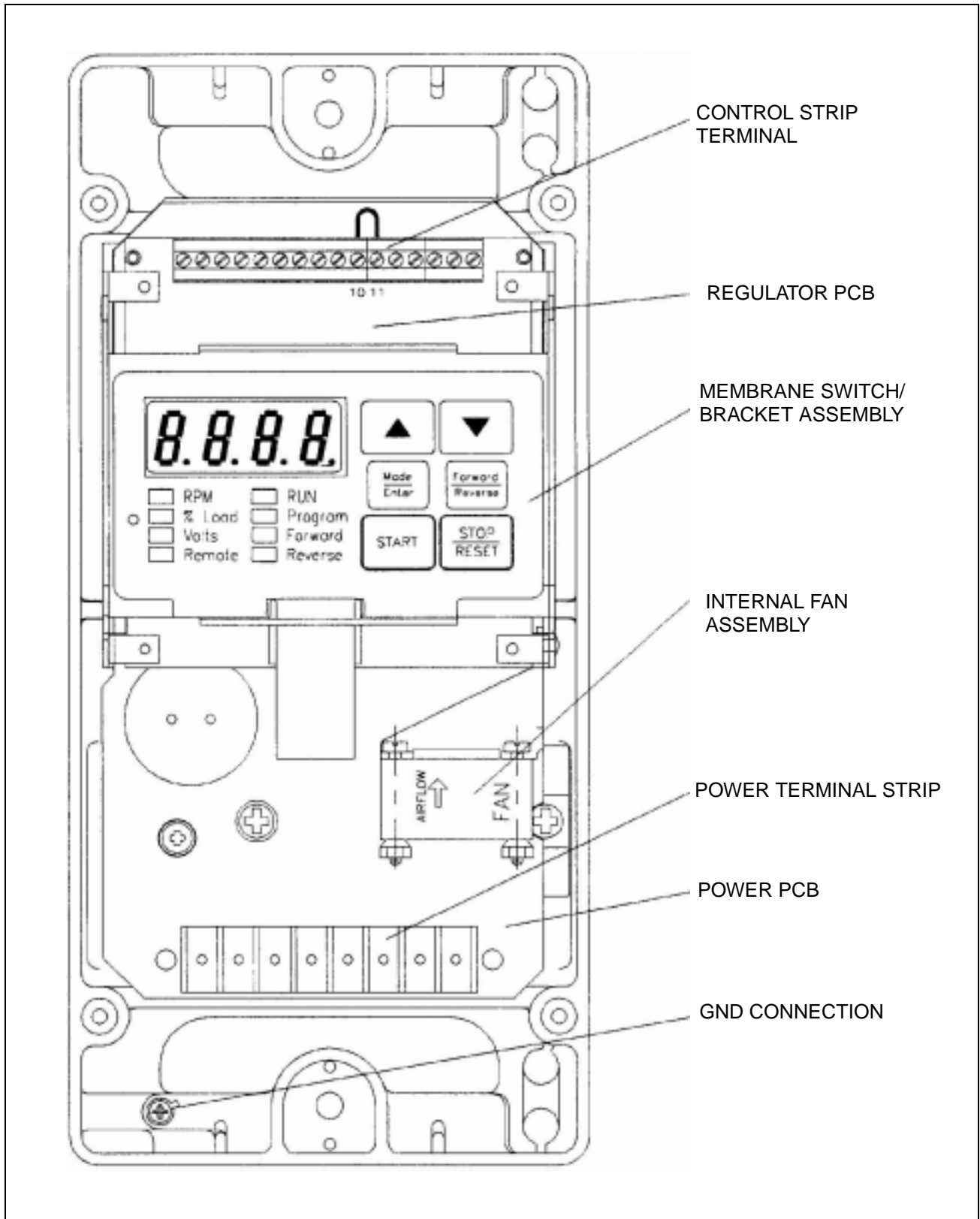

Figure 2.5 – Enclosure A Component Locations

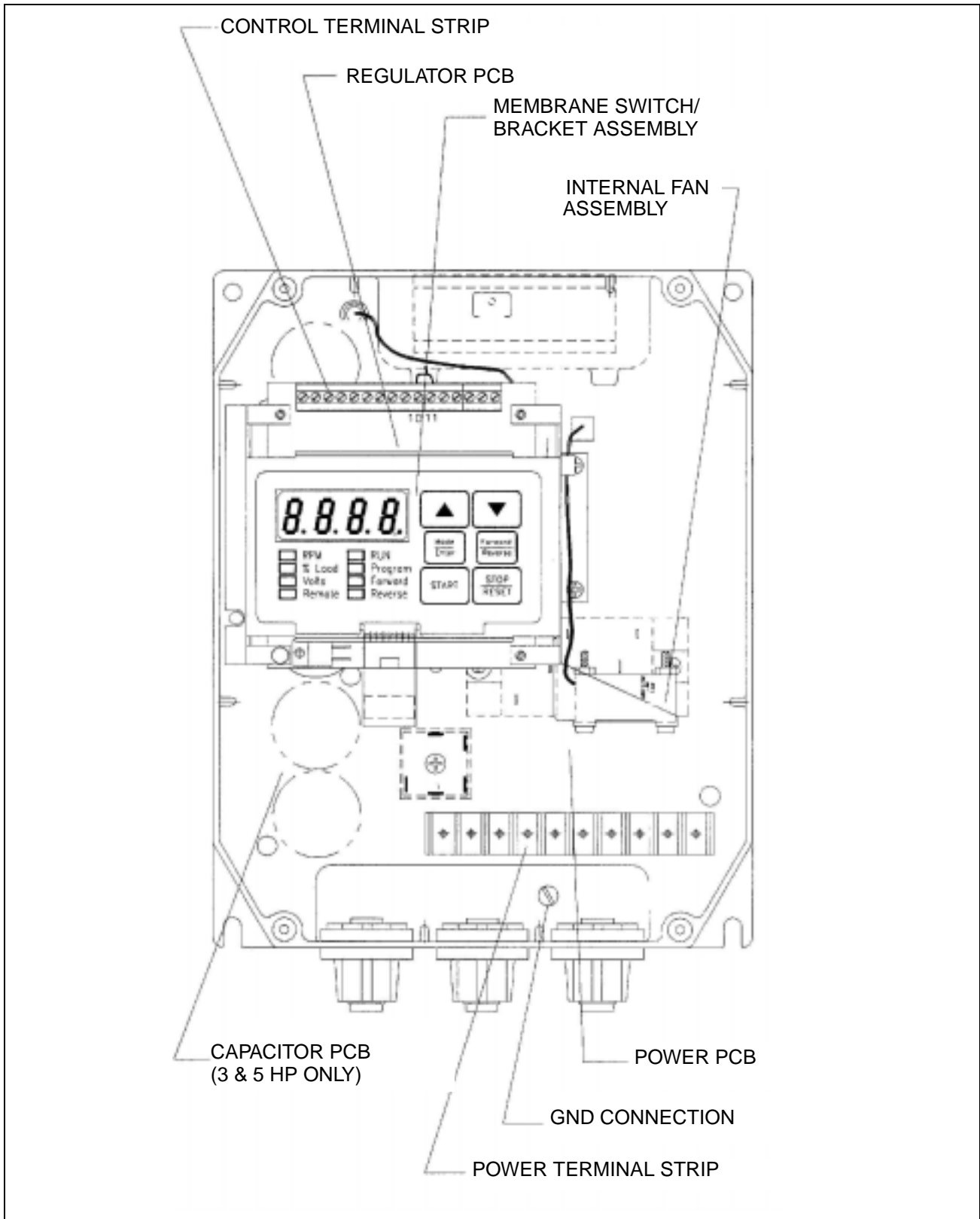

Figure 2.6 – Enclosure B Component Locations



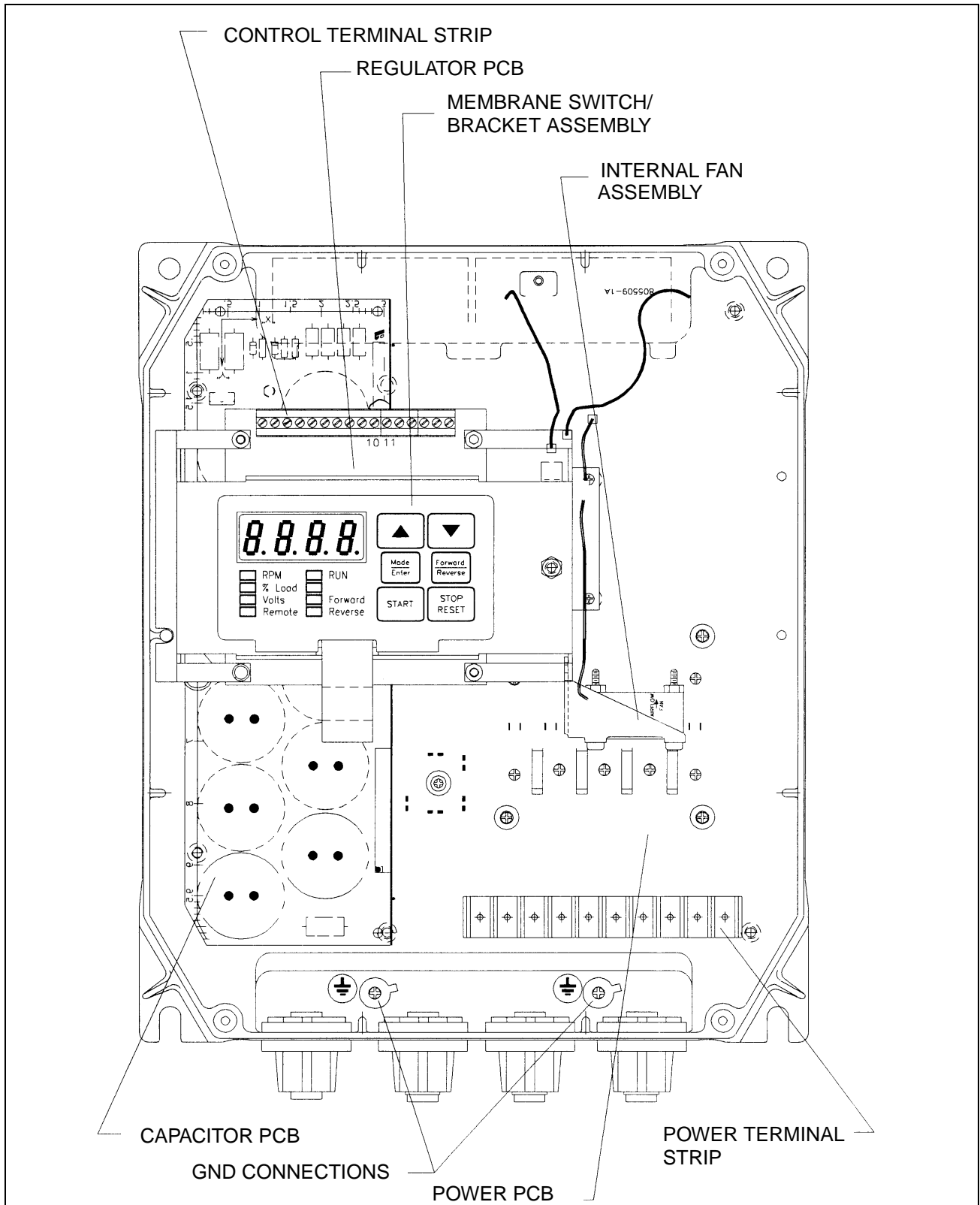

Figure 2.7 – Enclosure C Component Locations

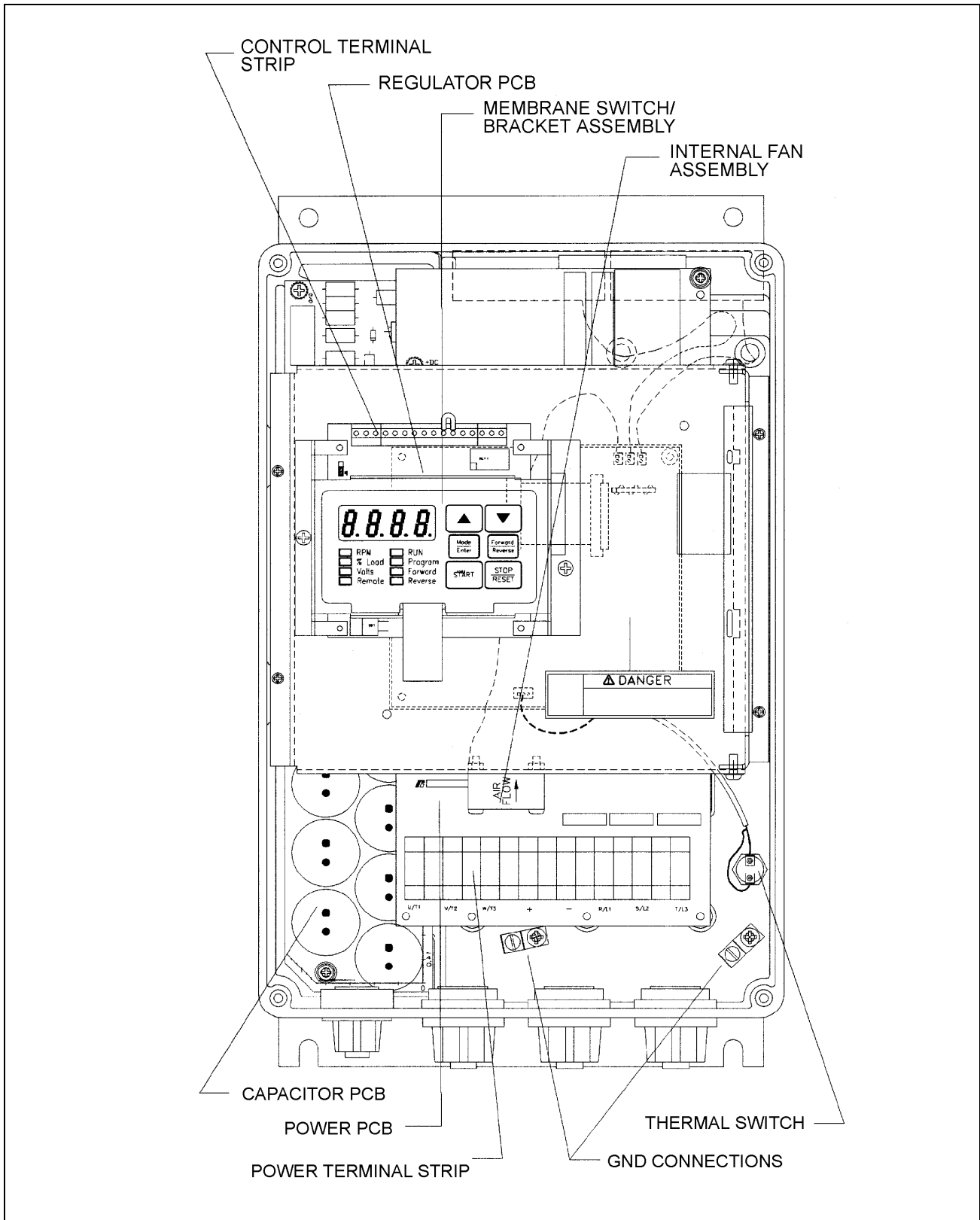

Figure 2.8 – Enclosure D Component Locations

## 2.5 Option Kits

Table 2.3 provides a listing of the available SP500 option kits.

Table 2.3 – SP500 Option Kits

<b>Option Kit Description</b>	<b>Option Kit Model Number</b>	<b>Instruction Manual</b>
Low Energy Snubber Resistor Braking Kit for M/N 1SU2xxxx Drives	2DB2005	D2-3178
Low Energy Snubber Resistor Braking Kit for M/N 1SU4xxxx Drives*	2DB4010	D2-3179
Low Energy Snubber Resistor Braking Kit for M/N 1SU4x015 and 1SU4x020 Drives	2SR40700 2SR41800	D2-3291
Low Energy Snubber Resistor Braking Kit for M/N 1SU5xxxx Drives*	2DB5010	D2-3180

\*Snubber resistor braking kits for M/N 1SU4xxxx and 1SU5xxxx drives require connection to the snubber resistor braking 10V power supply. See section 5.2.4 for more information.



## SP500 System Planning

This chapter provides information that you must consider when planning an SP500 drive installation. Installation site, wiring, and motor application requirements are included.



**ATTENTION:** Only qualified electrical personnel familiar with the construction and operation of this equipment and the hazards involved should install, adjust, operate, or service this equipment. Read and understand this manual and other applicable manuals in their entirety before proceeding.

**ATTENTION:** Use of power correction capacitors on the output of the drive can result in erratic operation of the motor, nuisance tripping, and/or permanent damage to the drive. Remove power correction capacitors before proceeding.

**ATTENTION:** The user is responsible for conforming with all applicable local, national, and international codes.

### 3.1 Installation Site Requirements

It is important to properly plan before installing an SP500 drive to ensure that the drive's environment and operating conditions are satisfactory. Note that no devices are to be mounted behind the drive. This area must be kept clear of all control and power wiring. Read the following recommendations before continuing with the drive installation.

Before deciding on an installation site, consider the following guidelines:

- The area chosen should allow the space required for proper airflow as specified in sections 3.1.1 and 3.1.2.
- Do not install the drive above 1000 meters (3300 feet) without derating output power. For every 91.4 meters (300 feet) above 1000 meters (3300 feet), derate the output current by 1%.
- Verify that the drive location will meet the following environmental conditions:
  - Operating temperature (ambient): 0 to +40°C (32 to 104°F)
  - Storage temperature (ambient): -40 to +65°C (-40 to +149°F)
  - Humidity: 5 to 95% (non-condensing)
- Verify that NEMA 1 drives can be kept clean, cool, and dry.
- Be sure NEMA 1 drives are located away from oil, coolants, or other airborne contaminants.
- Verify that the AC power distribution system meets the service conditions specified in table A.1.

### 3.1.1 Determining the Total Area Required for Installation

Figures 3.1 to 3.4 provide drive dimensions for enclosures A through D as an aid in calculating the total area required by the SP500 drives. Appendix A lists drive weights

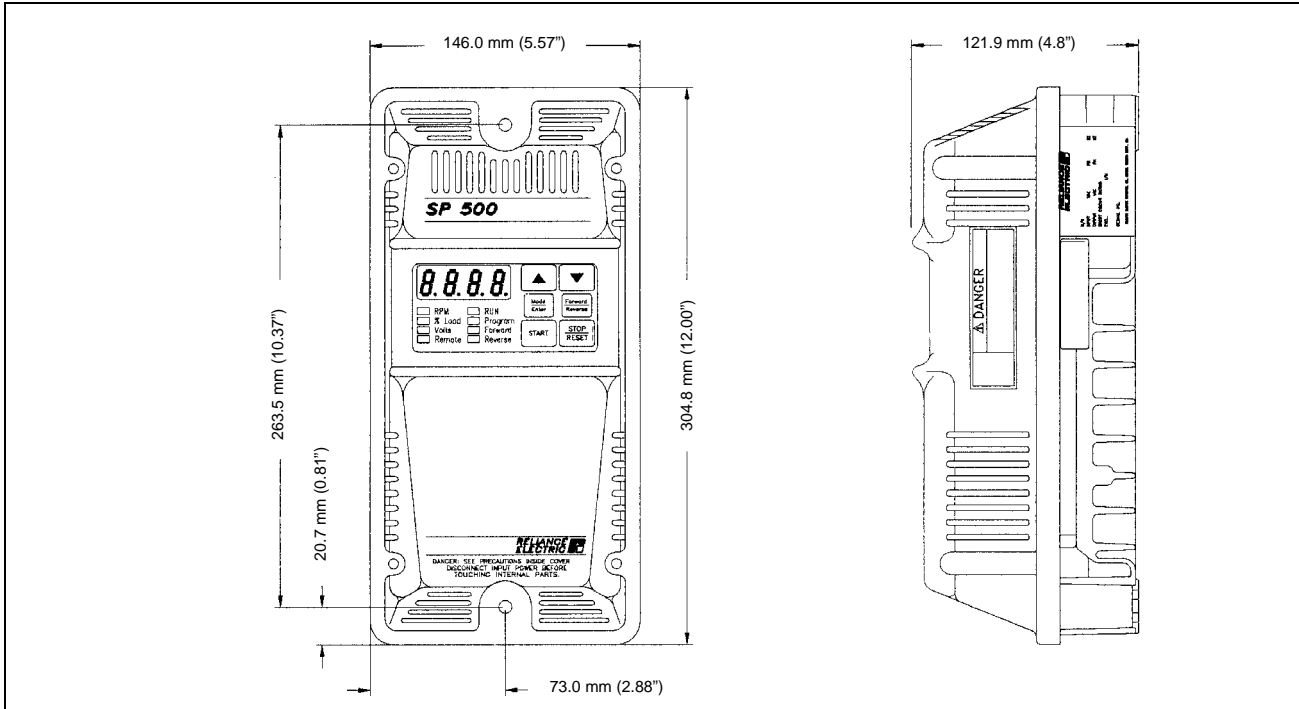

Figure 3.1 – Enclosure A Dimensions

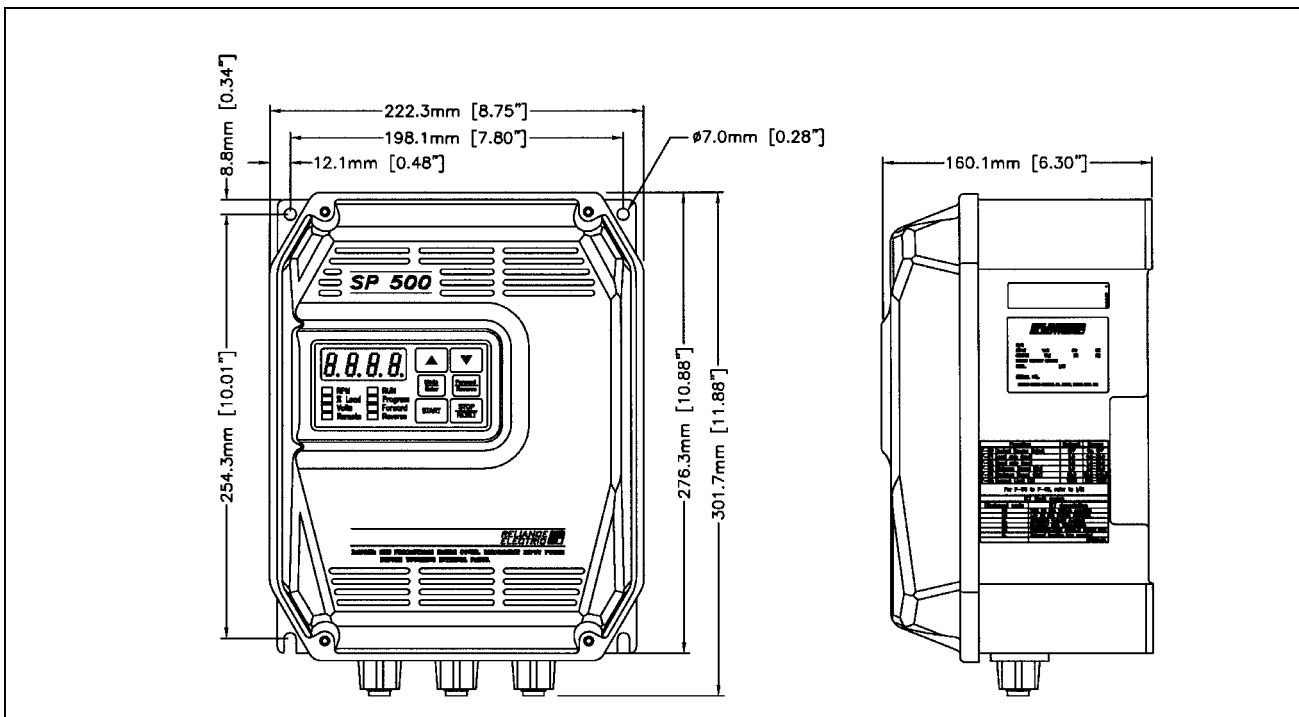

Figure 3.2 – Enclosure B Dimensions

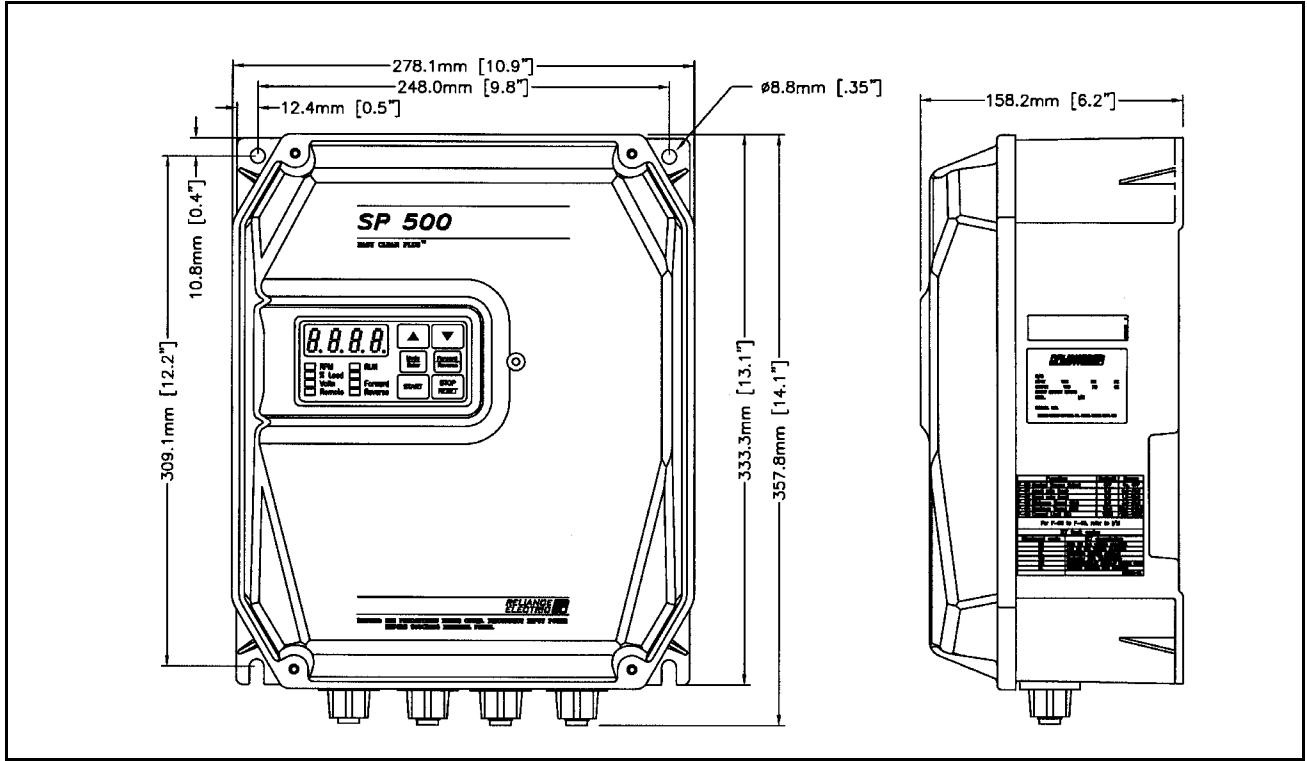

Figure 3.3 – Enclosure C Dimensions

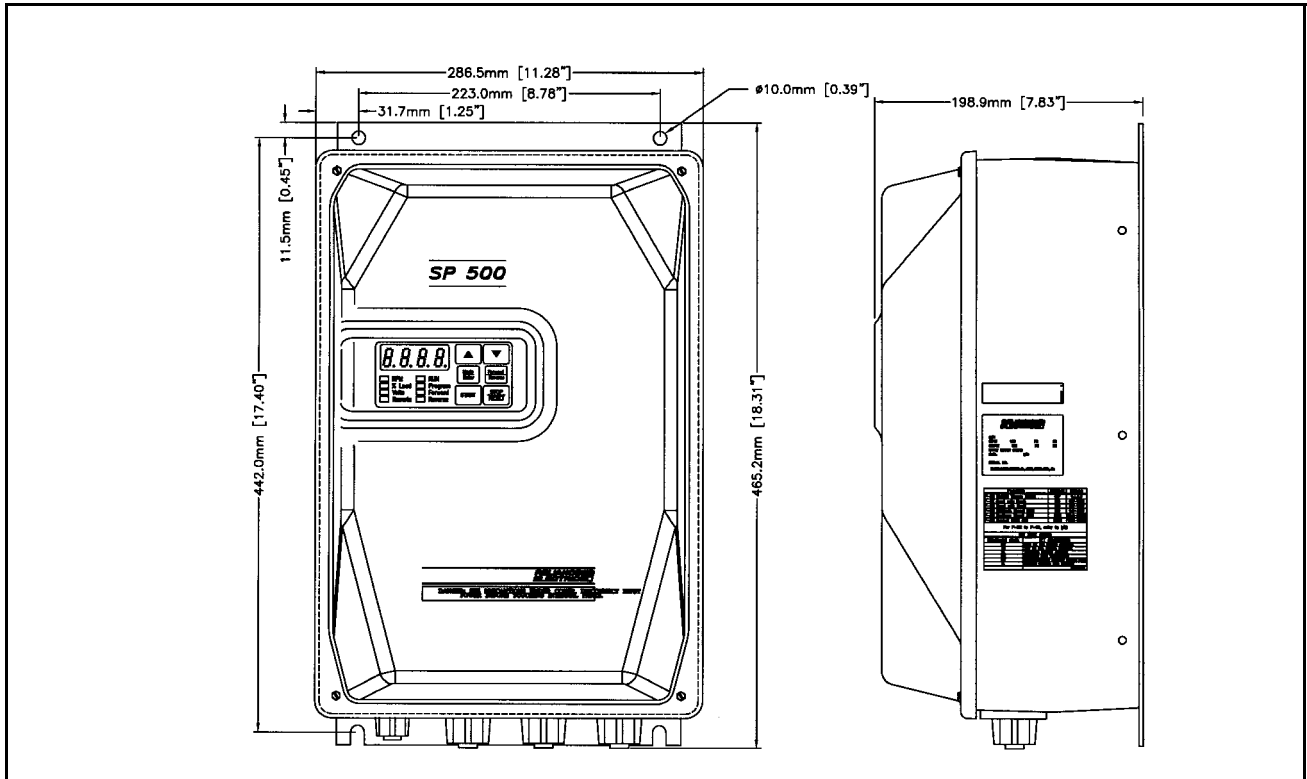

Figure 3.4 – Enclosure D Dimensions

### 3.1.2 Providing Proper Air Flow Clearances

Be sure there is adequate clearance for air ventilation around the drive. For best air movement, do not mount SP500 drives directly above each other. Note that no devices are to be mounted behind the drive. This area must be kept clear of all control and power wiring. See table 3.1 for a listing of the recommended air flow clearances.

Table 3.1 – Air Flow Clearances

	Enclosure			
	A	B	C	D
Minimum distance from the sides of the drive if adjacent to non-heat producing equipment	51 mm (2")	102 mm (4")	102 mm (4")	102 mm (4")
Minimum distance from the top and bottom of the drive if adjacent to non-heat producing equipment	102 mm (4")	102 mm (4")	102 mm (4")	102 mm (4")
Minimum distance from the sides of the drive if adjacent to other drives	51 mm (2")	102 mm (4")	102 mm (4")	102 mm (4")
Minimum distance from the top and bottom of the drive if adjacent to other drives	254 mm (10")	254 mm (10")	254 mm (10")	102 mm (4")

### 3.1.3 Verifying the Drive's Power Loss Rating

When installing an SP500 drive inside of another enclosure, you should consider the drive's watts loss rating shown in table 2.2. This table lists the typical full load power loss watts value under all operating carrier frequencies. Ensure adequate ventilation is provided based on the drive's watts loss rating.

## 3.2 Wiring Requirements

Evaluate the following areas of drive wiring before you do the installation: size of available conduit, size of power and control wiring, and motor lead lengths.

### 3.2.1 Verifying Conduit Sizes

It is important to determine the size of the conduit openings accurately so that the wire planned for a specific entry point will fit through the opening. Figures 4.1 through 4.4 show conduit opening sizes.

### 3.2.2 Recommended Power Wire Sizes

Size input power wiring according to applicable codes to handle the drive's continuous-rated input current. Size output wiring according to applicable codes to handle the drive's continuous-rated output current. Tables 3.2, 3.3, and 3.4 provide recommended power wiring sizes. Use only copper wire with a minimum temperature rating of 60/75°C. Table 3.5 contains the recommended tightening torque values for all power wiring terminals.



Table 3.2 – Recommended Power Wire Sizes for M/N 1SU1xxxx and 1SU2xxxx Drives

Type of Wiring	Terminals	Size of Wire (maximum)*
AC Input Power	R, S, T	14 AWG, 2 (mm <sup>2</sup> )
Output Power	U, V, W	14 AWG, 2 (mm <sup>2</sup> )
DC Bus	–, +	14 AWG, 2 (mm <sup>2</sup> )
Ground	GND	14 AWG, 2 (mm <sup>2</sup> )

\*Except for M/N 1SU21002 (single-phase input), 1SU21005, and 1SU24005, for which 12 AWG, 3 (mm<sup>2</sup>) wire is recommended.

Table 3.3 – Recommended Power Wire Sizes for M/N 1SU4xxxx and 1SU5xxxx Drives

Type of Wiring	Terminals	Size of Wire (maximum)*
AC Input Power	R(L1), S(L2), T(L3)	14 AWG, 2 (mm <sup>2</sup> )
Output Power	U(T1), V(T2), W(T3)	14 AWG, 2 (mm <sup>2</sup> )
DC Bus	–, +	14 AWG, 2 (mm <sup>2</sup> )
Snubber Resistor	+10 VDC, 10 COM	14 AWG, 2 (mm <sup>2</sup> )
Ground	GND	14 AWG, 2 (mm <sup>2</sup> )

\* Except for M/N 1SU41010 and 1SU44010, for which 12 AWG, 3 (mm<sup>2</sup>) wire is recommended.

Table 3.4 – Recommended Power Wire Sizes for M/N 1SU4x015 and 1SU4x020 Drives

Type of Wiring	Terminals	Size of Wire (maximum)
AC Input Power	R/L1, S/L2, T/L3	12 AWG, 3 (mm <sup>2</sup> )
Output Power	U/T1, V/T2, W/T3	12 AWG, 3 (mm <sup>2</sup> )
DC Bus	–, +	12 AWG, 3 (mm <sup>2</sup> )
Snubber Resistor	–, +	12 AWG, 3 (mm <sup>2</sup> )
Ground	GND	12 AWG, 3 (mm <sup>2</sup> )

Table 3.5 – Recommended Power Terminal Tightening Torque

Drives	Terminals	Maximum Tightening Torque
All	All power wires	1.08 Newton-meters (9.5 in-lb)

### 3.2.3 Recommended Control and Signal Wire Sizes

Table 3.6 shows the recommended wire sizes to connect I/O signals to the terminal strip on the Regulator board. The minimum wire insulation rating is 600V. Operator controls can be up to 303 meters (1000 feet) from the SP500 drive. All signal wires should be twisted-pair.

Table 3.6 – Recommended Control and Signal Wire Sizes and Tightening Torque

Drives	Terminals	Minimum Wire Size	Maximum Wire Size	Maximum Tightening Torque
All	1–16	20 AWG, 0.5 (mm <sup>2</sup> )	14 AWG, 2 (mm <sup>2</sup> )	0.5 Newton-meters (4.5 in-lb)

### 3.2.4 Recommended Motor Lead Lengths

The following motor lead lengths are recommended to reduce line disturbances and noise. See figure 3.5.

- For applications using one motor, motor lead length should not exceed 76 meters (250 feet).
- For applications with multiple motors, total motor lead length should not exceed 76 meters (250 feet).

When total lead length exceeds 76 meters (250 feet), nuisance trips can occur, caused by capacitive current flow to ground. Note that these capacitively-coupled currents should be taken into consideration when working in areas where drives are running. If the motor lead length must exceed these limits, the addition of output line reactors or other steps must be taken to correct the problem. See tables 3.7 and 3.8. Note that the motor lead lengths shown in table 3.7 are maximum distances. Your application may be restricted to a shorter motor lead length due to:

- the type of wire
- the placement of the wire (for example, in conduit or a cable tray)
- the type of line reactor
- the type of motor

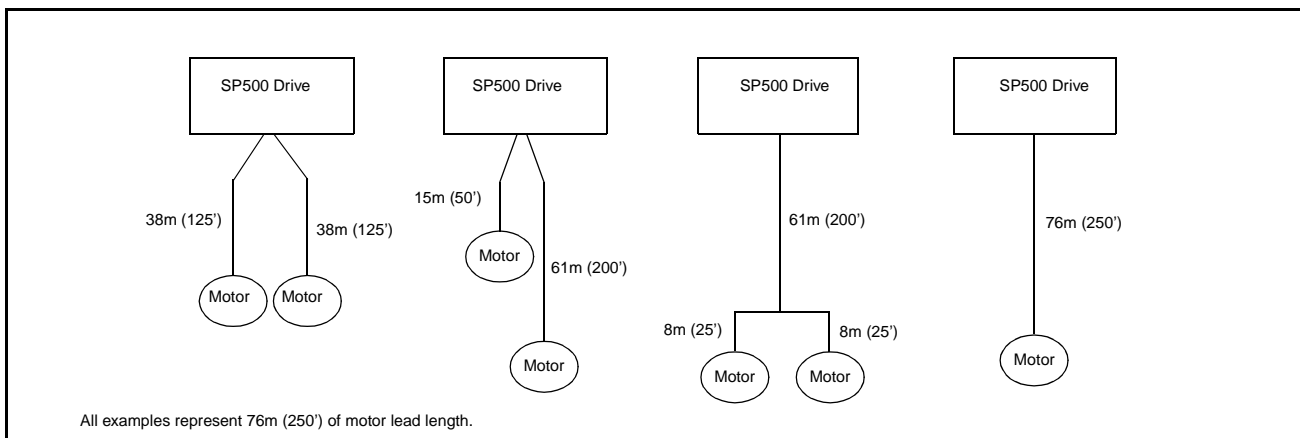

Figure 3.5 – How to Measure Motor Lead Lengths

Table 3.7 – Motor Lead Lengths

SP500 HP Rating	Filter Type	Maximum Lead Length in Feet with 230 VAC Motor			Maximum Lead Length in Feet with 460 VAC Motor			Maximum Lead Length in Feet with 575 VAC Motor		
		Carrier Frequency			Carrier Frequency			Carrier Frequency		
		4 kHz	6 kHz	8 kHz	4 kHz	6 kHz	8 kHz	4 kHz	6 kHz	8 kHz
1	None	500	500	500	250	250	250	150	150	150
2		500	500	500	350	350	350	250	200	200
3		1000	1000	1000	400	400	400	250	200	200
5		1000	1000	1000	500	500	500	250	200	200
7.5 to 10		N/A	N/A	N/A	500	500	500	250	250	250
15 to 20		N/A	N/A	N/A	500	500	500	N/A	N/A	N/A
1	A 5% MTE reactor/filter at the drive.	A reactor/filter is not required. Above lead lengths are maximum distances.			500	500	500	500	500	500
2					500	500	500	500	500	500
3					1000	1000	1000	1000	1000	1000
5					1000	1000	1000	1000	1000	1000
7.5 to 10		N/A	N/A	N/A	1000	1000	1000	1000	1000	1000
15 to 20		N/A	N/A	N/A	1000	1000	1000	N/A	N/A	N/A

- Note that the lead lengths listed are valid with Reliance Electric inverter duty motors.
- N/A indicates that the drive does not have this rating or it is not applicable.

Table 3.8 – Reactors

SP500 HP Rating	230 Volt 5% MTE Reactor	480 Volt 5% MTE Reactor	600 Volt 5% MTE Reactor
1	RL-00402	RL-00202	RL-00203
2		RL-00403	RL-00404
3		RL-00403	RL-00404
5		RL-00803	RL-00804
7.5		RL-01203	RL-00803
10		RL-01803	RL-01203
15		RL-02503	
20		RL-03503	

- MTE standard reactors can be used on SP500 drives with carrier frequency settings up to 8 kHz.
- All reactors listed are UL-recognized (UL-506 File #E53094) and CSA certified (CSA File #LR29753).

### 3.3 Selecting Input AC Line Branch Circuit Fuses



**ATTENTION:** Most codes require that upstream branch circuit protection be provided to protect input power wiring. Install the fuses recommended in table 3.9. Do not exceed the fuse ratings.

Input line branch circuit protection fuses must be used to protect the input power lines. See figure 5.1. Table 3.9 shows recommended fuse values. These fuse ratings are applicable for one drive per branch circuit. No other load may be applied to that fused circuit. Note that contactors and circuit breakers are not recommended for AC input line branch protection.

Table 3.9 – AC Input Line Fuse Selection Values

Model Number	Fuse Rating*		Model Number	Fuse Rating*		Model Number	Fuse Rating*
1SU11001	20A		1SU41001	6A		1SU51001	4A
1SU14001	12A		1SU44001	6A		1SU54001	4A
			1SU41002	8A		1SU51002	7A
1SU21001	10A		1SU44002	8A		1SU54002	7A
1SU24001	10A		1SU41003	12A		1SU51003	10A
1SU21002	30A		1SU44003	12A		1SU54003	10A
			1SU41005	25A		1SU51005	15A
1SU21001	12A		1SU44005	25A		1SU54005	15A
1SU24001	12A		1SU41007	25A		1SU51007	20A
1SU21002	20A		1SU44007	25A		1SU54007	20A
1SU24002	20A		1SU41010	35A		1SU51010	25A
1SU21003	25A		1SU44010	35A		1SU54010	25A
1SU24003	25A		1SU41015	45A			
1SU21005	35A		1SU42015	45A			
1SU24005	35A		1SU41020	55A			
			1SU42020	55A			

\* Recommended fuse type: UL Class J, 600V, time-delay, or equivalent.

## 3.4 Installing an Emergency Stop



**ATTENTION:** The user must provide an external, hardwired emergency stop circuit outside of the drive circuitry. This circuit must disable the system in case of improper operation. Uncontrolled machine operation may result if this procedure is not followed.

Depending upon the requirements of the application, the SP500 drive can be programmed to provide either a coast-to-rest (default) or a ramp-to-rest (user-option) operational stop without physical separation of the power source from the motor. Refer to sections 5.2 and 8.3 (parameter F-16) for more information on how to program an operational stop.

In addition to the operational stop, users must provide a hardwired emergency stop external to the drive. The emergency stop circuit must contain only hardwired electromechanical components. Operation of the emergency stop must not depend on electronic logic (hardware or software) or on the communication of commands over an electronic network or link.

### 3.4.1 Complying with Machinery Safety Standard EN 60204-1:1992

This section applies to users who must comply with machinery safety standard EN 60204-1:1992, part 9.2.5.4, Emergency Stop.

The SP500 drive coast-to-rest stop is a category 0 operational stop. The ramp-to-rest stop is a category 1 operational stop.

The required external hardwired emergency stop must be either a category 0 or 1 stop, depending on the user's risk assessment of the associated machinery. In order to fully comply with machinery safety standard EN 60204-1:1992, part 9.2.5.4, at least one of the two stop methods must be a category 0 stop. Refer to Appendix D for more information.

## 3.5 Motor Considerations

To obtain motor nameplate horsepower, the drive's output current rating at the selected carrier frequency should be equal to or greater than motor nameplate current. If the motor nameplate current rating is higher than the drive's output current rating, derate motor horsepower by the ratio of the drive's output ampere rating (at the selected carrier frequency) to the motor nameplate current. Note that this approximation is only accurate if the drive and the motor have nearly the same rating.

### 3.5.1 Single-Motor Applications

Size the drive and motor for the load and speed requirements of the specific application.

The motor's operating current must not exceed the drive's rated output current (at the selected carrier frequency). In addition, the motor's horsepower rating (for example, 1, 2, 3, 5, 7, 10, 15, and 20 HP) must not be more than one horsepower range larger than the drive's horsepower rating.

If the motor will be operated below one-half of its rated speed, the motor overload relay may not protect the motor because of reduced cooling action due to the reduced speed. A motor thermostat, internal to the motor, should be installed to monitor the actual temperature of the windings.

### 3.5.2 Multiple-Motor Applications

One drive can run two or more motors. Adhere to the following requirements to assure correct drive operation in this case:

- When starting and stopping all the motors at the same time (using the drive for starting and stopping), the sum of the full-load sine wave currents of all the motors must be equal to or less than the maximum sine wave output current at the selected carrier frequency for the drive.

For example:

$$\begin{array}{ccccccc} I_{FLA} & + & I_{FLA} & + & I_{FLA} & = & I_{TLA} \\ \text{(Motor 1)} & & \text{(Motor 2)} & & \text{(Motor 3)} & & \text{(Total Load)} \end{array}$$

Where:  $I_{TLA} \leq 100\%$  rated drive output at the selected carrier frequency

- When one or more of the motors connected to the output of the drive are to start independently (using a secondary switching device to add or remove the motor from the circuit):

Any motor that starts or stops while the drive is running must have a current rating less than 10% of the maximum sine wave current rating of the drive at the selected carrier frequency.

The sum of the maximum full-load sine wave currents of all the motors connected continuously to the drive must be less than the maximum output current rating under all conditions.

Note that each motor requires separate thermal overload protection (for example, a motor relay or a motor thermostat).

## Installing the Drive

This chapter shows how to mount the SP500 drive and its external components. Also shown are the entry areas for routing wiring in and out of the drive.

### 4.1 Mounting the Drive

Attach the drive to the selected flat, vertical surface using the mounting holes provided. Enclosure A drives have two mounting holes, which are accessible after the cover is removed. Enclosure B, C, and D drives have four mounting holes. In order to maintain a flat mounting surface and to ensure that bolt tightness is maintained, use washers under the bolt heads. Refer to figures 3.1 through 3.4 for drive mounting dimensions. Use the following user-supplied mounting bolts and washers:

- Enclosure A drives: two M6 (1/4")
- Enclosure B drives: four M8 (5/16")
- Enclosure C drives: four M8 (5/16")
- Enclosure D drives: four M8 or M10 (5/16" or 3/8")

### 4.2 Routing Wires

All wiring should be installed in conformance with the applicable local, national, and international codes (e.g., NEC/CEC). Signal wiring, control wiring, and power wiring must be routed in separate conduits to prevent interference with drive operation. Do not route wires behind the drive. Use grommets when hubs are not provided to guard against wire chafing. Figures 4.1 through 4.4 show the wire routing, grounding terminal, and power terminal strips of the SP500 drives.



**ATTENTION:** Do not route signal and control wiring in the same conduit with power wiring. This can cause interference with drive operation.

Do not route more than three sets of motor leads through a single conduit. This will minimize cross-talk that could reduce the effectiveness of noise reduction methods. If more than three drive/motor connections per conduit are required, you must use shielded cable. If possible, each conduit should contain only one set of motor leads.



**ATTENTION:** Unused wires in conduit must be grounded at both ends to avoid a possible shock hazard caused by induced voltages. Also, if a drive sharing a conduit is being serviced or installed, all drives using this conduit should be disabled to eliminate the possible shock hazard from cross-coupled motor leads.





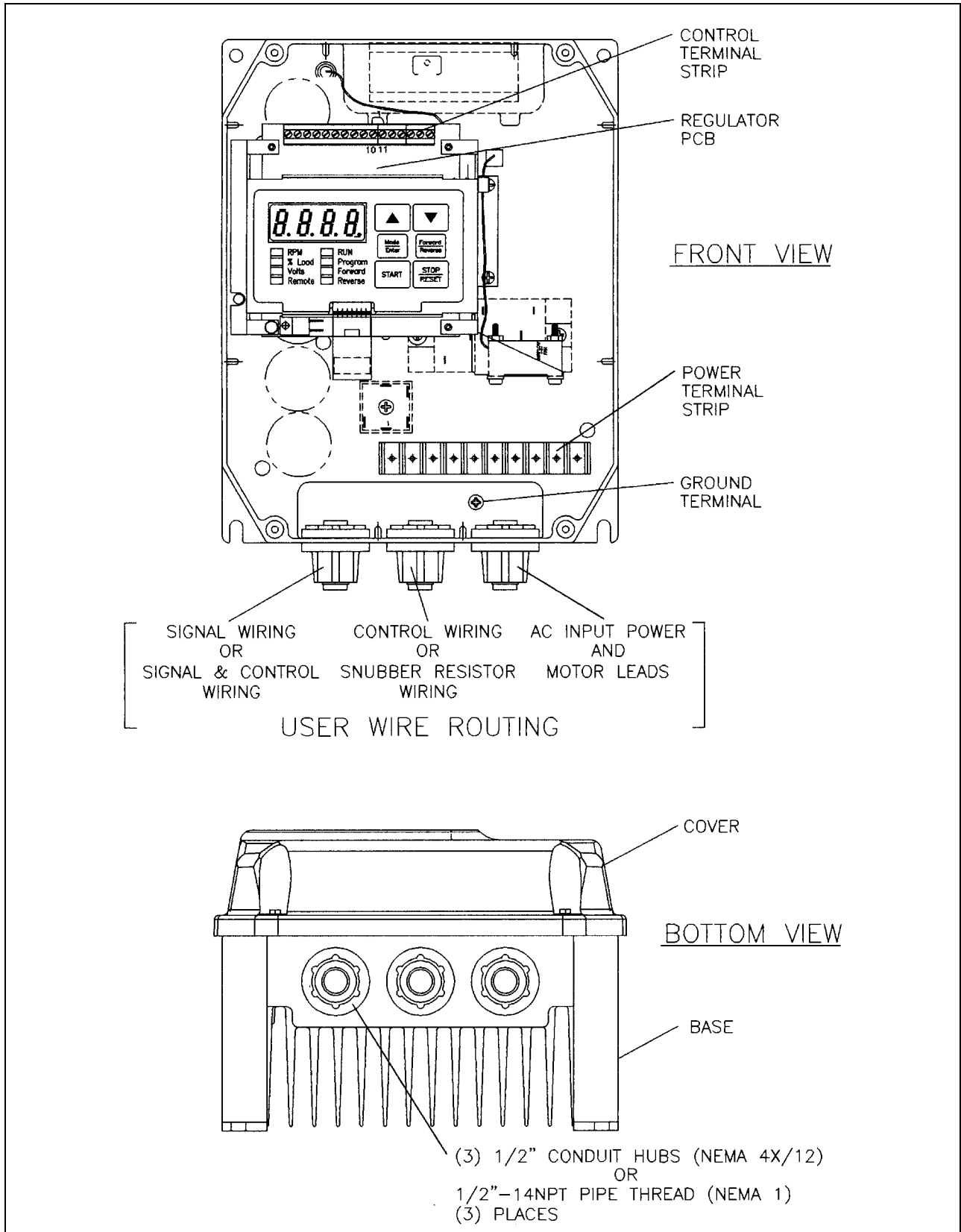

Figure 4.2 – Enclosure B Wire Routing Locations

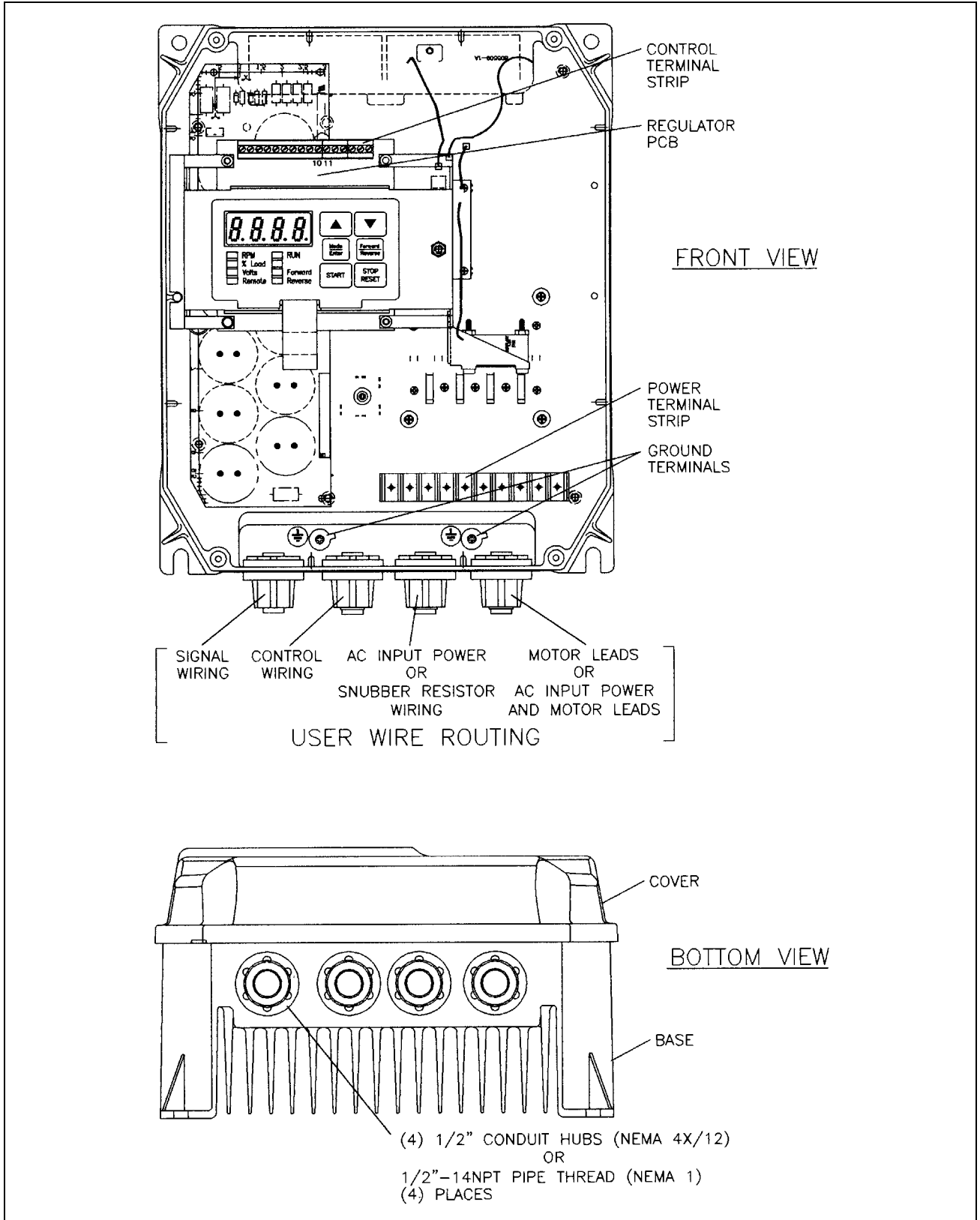

Figure 4.3 – Enclosure C Wire Routing Locations

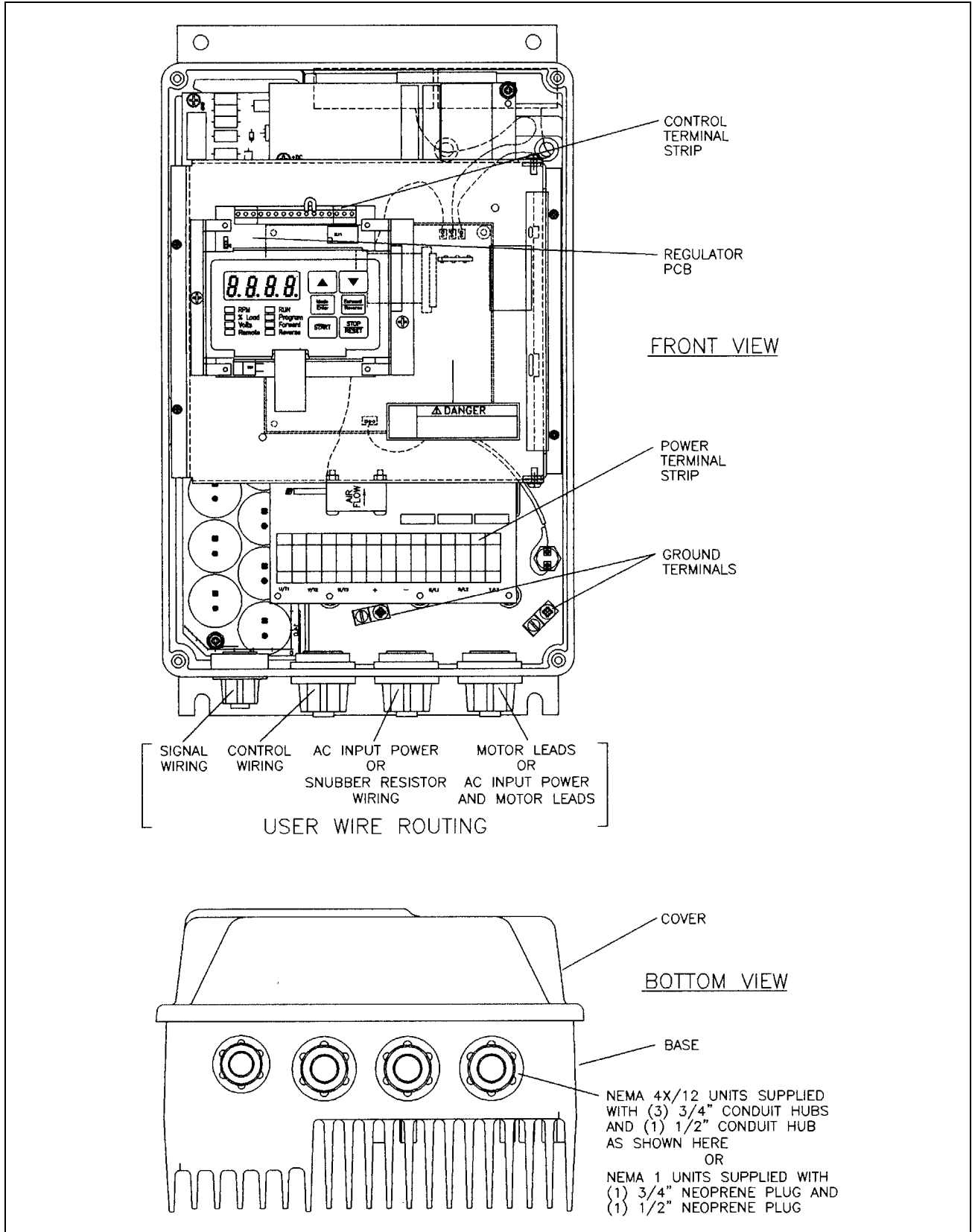

Figure 4.4 – Enclosure D Wire Routing Locations

## 4.3 Installing External Components

Install the input power and output power components that are located outside of the SP500 enclosure. See figure 5.1. The following sections describe disconnect, transformer, and AC line branch protection installation.

### 4.3.1 Disconnects

An input disconnect (for example, a switch or circuit breaker) must be installed in the line before the drive input terminals in accordance with local, national, and international codes (e.g., NEC/CEC). Size the disconnect according to the inrush current as well as any additional loads the disconnect might supply. Coordinate the trip rating for the current (10 to 12 times the full load current) with that of the input isolation transformer, if used. Refer to section 4.3.3 for additional information.

### 4.3.2 Input AC Line Branch Protection



**ATTENTION:** Most codes require that upstream branch protection be provided to protect input power wiring.

User-supplied branch circuit protection fuses must be installed according to the applicable local, national, and international codes (for example, NEC/CEC). The fuses must be installed in the line before the drive's AC input terminals. Table 3.9 provides fuse values.

### 4.3.3 Transformers



**ATTENTION:** Distribution capacity above the maximum recommended system KVA rating (100 KVA for 115/230 VAC, 1000 KVA for 460/575 VAC) requires the use of an isolation transformer, a line reactor, or other means of adding similar impedance to the drive's input power wiring.

**ATTENTION:** When the AC line is shared directly with other SCR-rectified drives, an optional snubber resistor braking kit might be required to alleviate excess DC bus voltage

Input isolation transformers may be needed to help eliminate the following:

- Damaging line voltage transients.
- Line noise from the drive back to the incoming power source.
- Damaging currents that could develop if a point inside the drive becomes grounded.

Observe the following guidelines when installing an isolation transformer:

- A power disconnecting device must be installed between the power line and the primary of the transformer. If the power disconnecting device is a circuit breaker, the circuit breaker trip rating must be coordinated with the inrush current (10 to 12 times the full load current) of the transformer.

- Do NOT use an input isolation transformer rated more than 100 KVA for 230 VAC (or 1000 KVA for 460 VAC) with less than 5% impedance directly ahead of the drive without additional impedance between the drive and the transformer.

If your SP500 application requires the use of an output transformer, contact Reliance Electric for assistance.

#### 4.3.4 Output Contactors



**ATTENTION:** Any disconnecting means wired to drive output terminals U, V, and W must be capable of disabling the drive if opened during drive operation. If opened during drive operation, the drive will continue to produce output voltage between U, V, W. An auxiliary contact must be used to simultaneously disable the drive or output component damage may occur.

Output contactors provide a positive means of disconnecting the motor from the drive. If your SP500 application requires the use of output contactors, contact Reliance Electric for assistance.

#### 4.3.5 Mechanical Motor Overload Protection

To provide the motor with overload protection, local, national, and international codes (for example, NEC/CEC) require that a motor thermostat, internal to the motor, be installed or an electronic thermal motor overload relay, sized to protect the motor, be installed between the motor and the drive's output terminals.

The Electronic Thermal Overload parameter (F-14) may be used in place of the electronic thermal motor overload relays in single motor applications. Note, however, that temperature-sensing devices integral to the motor are the best way of thermally-protecting AC motors under all conditions. Parameter F-14 must be enabled to provide overload protection. Refer to section 8.3 for the parameter description.

In multiple motor applications, each motor must have its own user-supplied overload protection.

### 4.4 Setting the Analog Input Jumper on the Regulator Board

SP500 drives have an analog speed reference input. This is a jumper-selectable 0 to 10 VDC or 0 to 20 mA input with programmable gain and offset adjustments (parameters F-11 and F-12). Jumper J6 on the Regulator board is set to match the type of incoming analog signal, either voltage or current. See figures 2.2, 4.5, and 5.3. Refer to section 5.2.1 for more information.

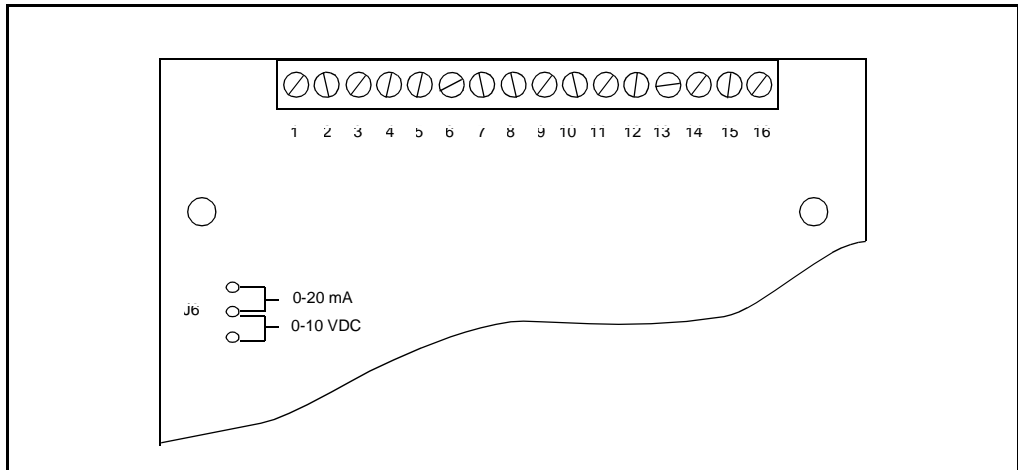

Figure 4.5 – Jumper J6 Settings for the Analog Input Speed Reference

Use the following procedure to set jumper J6:



**ATTENTION:** DC bus capacitors retain hazardous voltages after input power has been disconnected. After disconnecting input power, wait five (5) minutes for the DC bus capacitors to discharge and then check the voltage with a voltmeter to ensure the DC bus capacitors are discharged before touching any internal components.

- Step 1. Turn off and lock out input power. Wait five minutes.
- Step 2. Remove the cover from the drive by unscrewing the four cover screws.
- Step 3. Verify that the DC bus voltage is zero by following the procedure in section 9.1.
- Step 4. Locate jumper J6 on the Regulator board. Refer to figure 2.3.
- Step 5. Move the jumper to the desired setting as shown in figure 4.5.
- Step 6. Reattach the cover.
- Step 7. Reapply input power.
- Step 8. Verify that parameters F-11 and F-12 are correctly set.

Note that if the setting of jumper J6 is changed, the regulator software will not automatically detect it. Verify that parameters F-11 (gain) and F-12 (offset) are set correctly before starting the drive.

## 4.5 Preparing the Motor

Follow these guidelines when preparing to install the motor:

- Verify that the motor is the appropriate size to use with the drive.
- Verify that the total motor lead length does not exceed the values given in section 3.2.4.
- Follow the instructions in the motor instruction manual when installing the motor.

- Verify that the motor is properly aligned with the application's machine to minimize unnecessary motor loading due to shaft misalignment.
- If the motor is accessible when it is running, install a protective guard around all exposed rotating parts.





This chapter describes how to wire the SP500 drive including: input wiring, control and signal wiring, output wiring, and grounding.

### 5.1 Input Power Wiring

Use the following steps to connect AC input power to the drive:

- Step 1. Verify that the AC input power to the drive corresponds to the drive's nameplate voltage and frequency.
- Step 2. Wire the AC input power leads by routing them according to the type of enclosure. See figures 4.1 through 4.4. See tables 3.2 through 3.4 for recommended wire sizes.



**ATTENTION:** Do not route signal and control wiring with power wiring in the same conduit. This can cause interference with drive operation.

- Step 3. Connect the AC input power leads to terminals R,S,T on the power terminal strip. See figure 5.1.
- Step 4. Tighten terminals R and S (single-phase input) or terminals R,S,T (three-phase input) to the proper torque as shown in table 3.5.

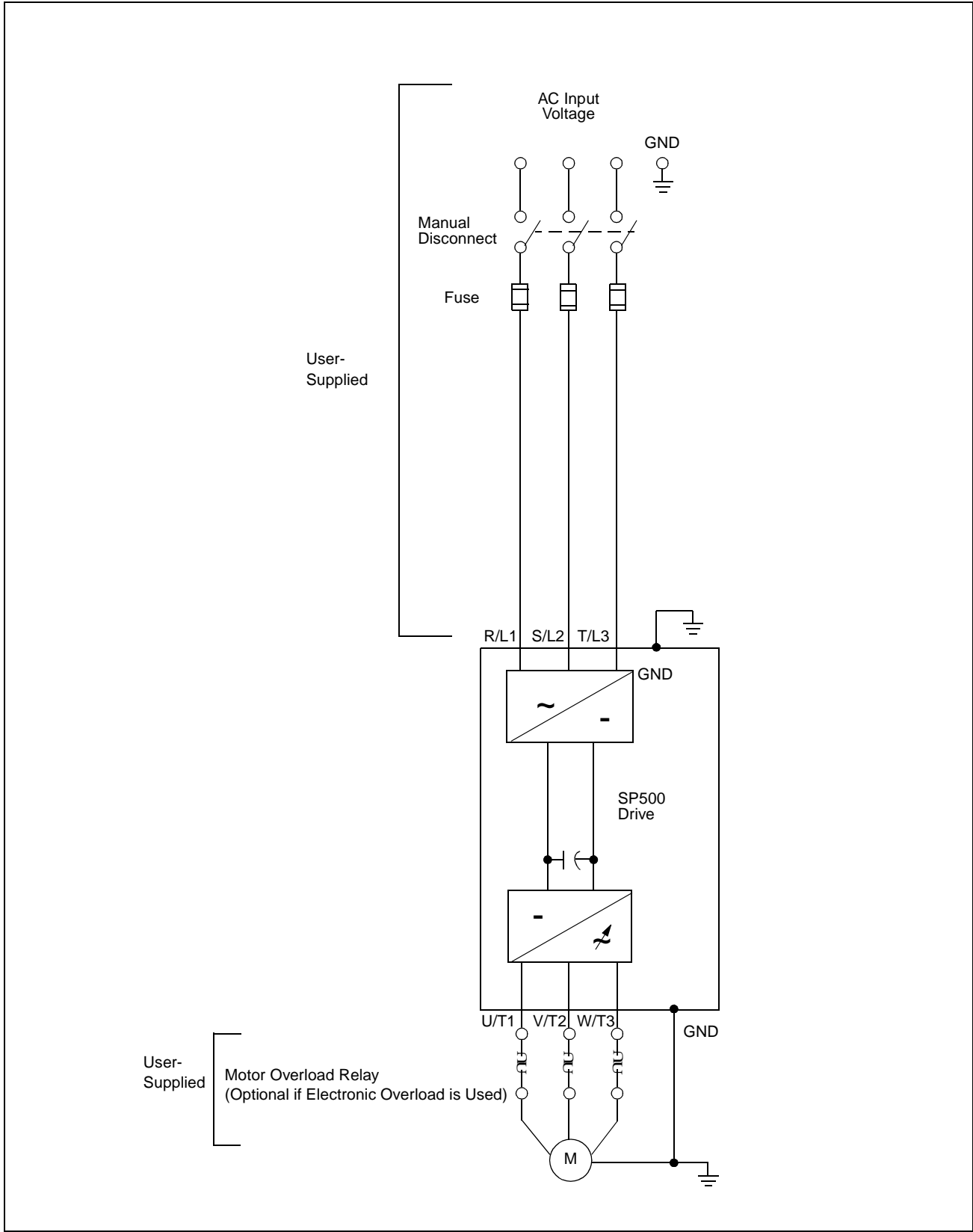

Figure 5.1 – Typical Electrical Connections

## 5.2 Signal and Control Wiring

The terminal strip on the Regulator board provides terminals for connecting signal (for example, external speed reference and analog output) and control (for example, stop, start, and function loss) wiring. See figure 5.2. Terminals for the following wire connections are provided:

- Terminals 1-3: analog speed reference connections
- Terminals 4-5: analog output connections
- Terminals 6-11: digital input connections
- Terminals 12-13: snubber resistor connections
- Terminals 14-16: output status connections

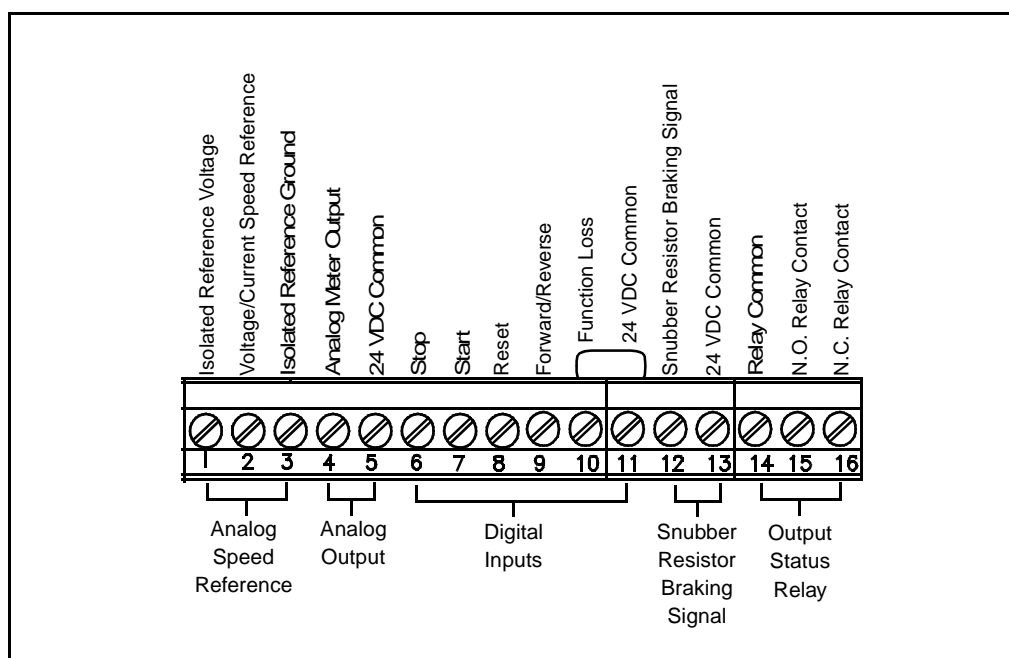

Figure 5.2 – Typical Control Terminal Strip Connections

### 5.2.1 Analog Speed Reference Wiring

Analog speed reference input wiring connects to terminals 1 through 3 on the Regulator board's terminal strip. See figure 5.3. This reference signal is jumper-selectable for either a 0 to 10 VDC or 0 to 20 mA input. The setting of jumper J6 on the Regulator board determines whether the input reference is a voltage or current signal. This reference signal can be provided by either a user-supplied 5K ohm potentiometer or an external 0-10 VDC/0-20 mA supply. See section 4.4 for more information.

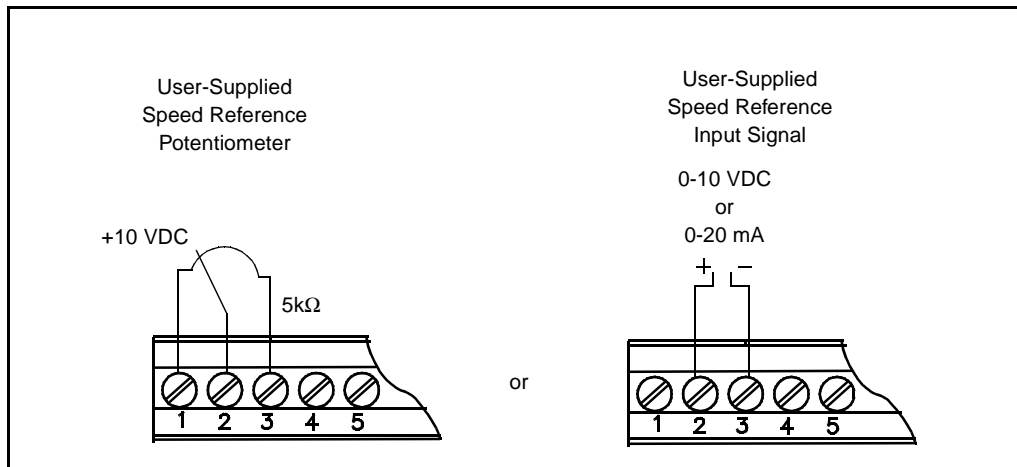

Figure 5.3 – Analog Speed Reference Wiring Connections

## 5.2.2 Analog Output Wiring

Analog output wiring connects to terminals 4 and 5 on the Regulator board's terminal strip. See figure 5.4. This is a scaled 0 to 10 VDC output signal that is proportional to either current speed, percent of load, calculated output voltage, or percent of the selected reference value, whichever is selected through parameter F-29. This output signal is available during both local and remote operation.

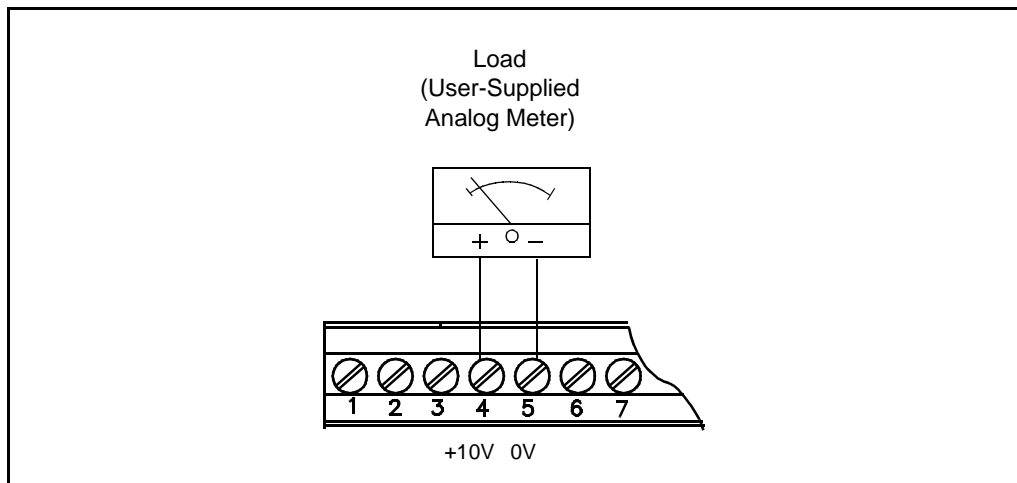

Figure 5.4 – Analog Output Wiring Connections

## 5.2.3 Digital Input Wiring

Digital input wiring connects to terminals 6 through 11 on the Regulator board's terminal strip. The drive has a 24 VDC power supply that provides the required voltage for control signals. Enabling or disabling a control signal requires that a contact (switch) be opened or closed.

**Important:** The 24 VDC power supply is unregulated and will nominally supply 24 VDC. It is not to be used with any external devices other than the inputs to the drive.

## Start and Stop Control Wiring

Start and stop control wiring connects to terminals 6, 7, and 11. See figures 5.5 and 5.6. Note that these start/stop wiring connections are not to be used in multi-speed preset applications which are discussed in the following section.

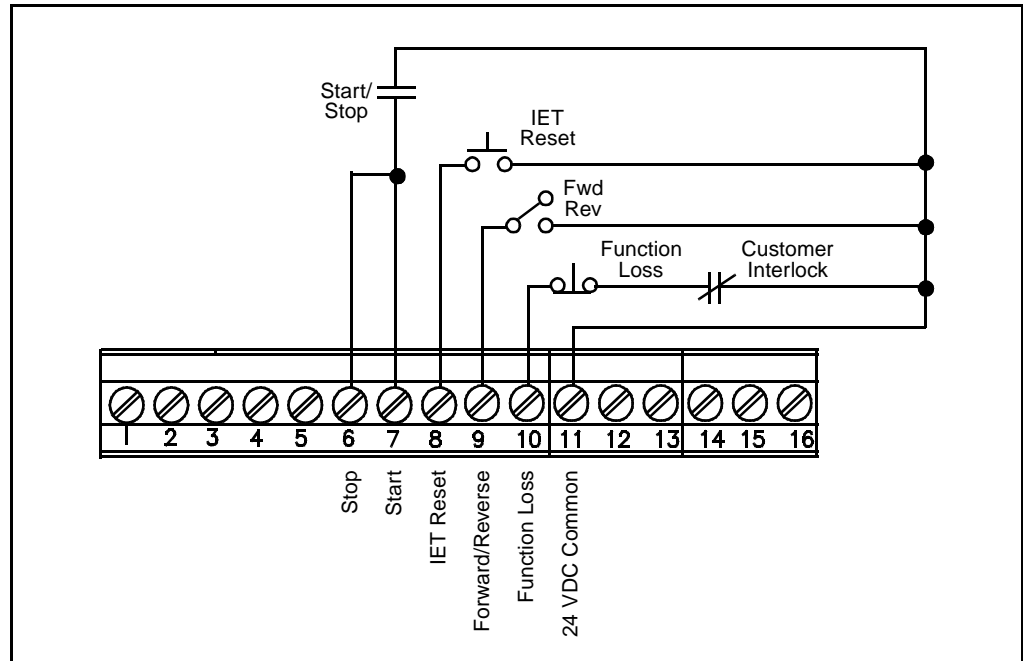

Figure 5.5 – Two-Wire Start/Stop Sample Control Wiring

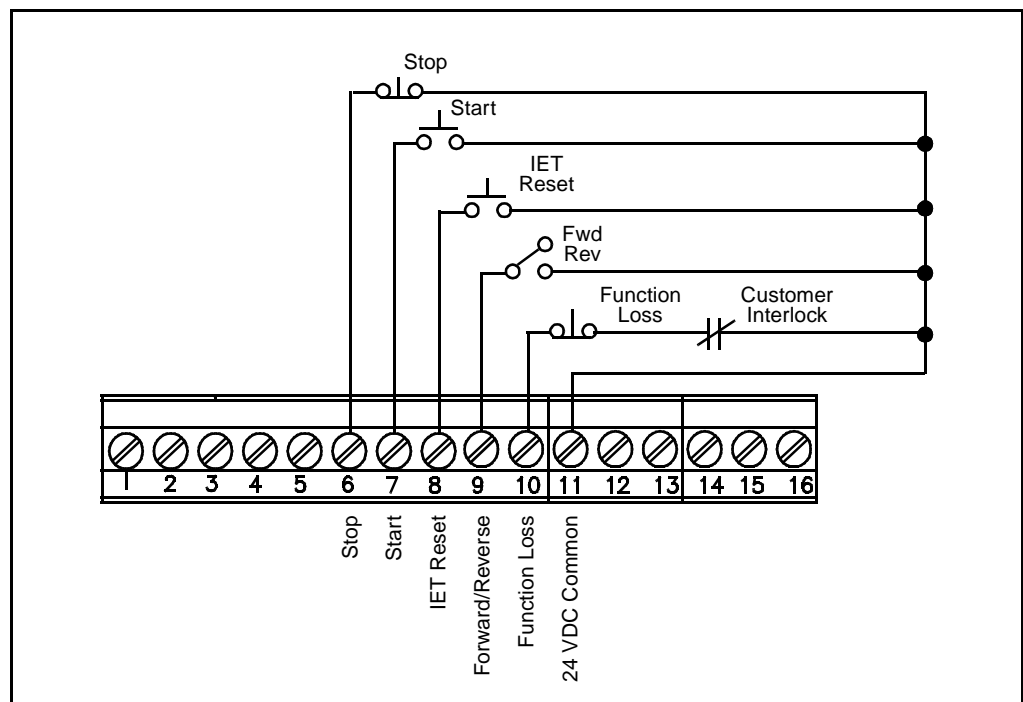

Figure 5.6 – Three-Wire Start/Stop Sample Control Wiring

## Multi-Speed Preset Wiring

Multi-speed preset wiring connects to terminals 6 through 8, and 11. See figure 5.7. When control type 3 is selected through parameter F-00, remote terminal strip control is enabled with multi-speed presets. This mode of operation changes the functionality of terminals 6 through 8 and may be used in place of 2- and 3-wire start/stop wiring. See figure 5.8.

When you enable multi-speed preset operation, the state of terminals 7 and 8 determine the source of the speed reference:

Terminal 7	Terminal 8	Speed Reference Source
0	0	Terminal Strip Analog Input
0	1	Multi-Speed Preset 1 (Parameter F-23)
1	0	Multi-Speed Preset 2 (Parameter F-24)
1	1	Multi-Speed Preset 3 (Parameter F-25)

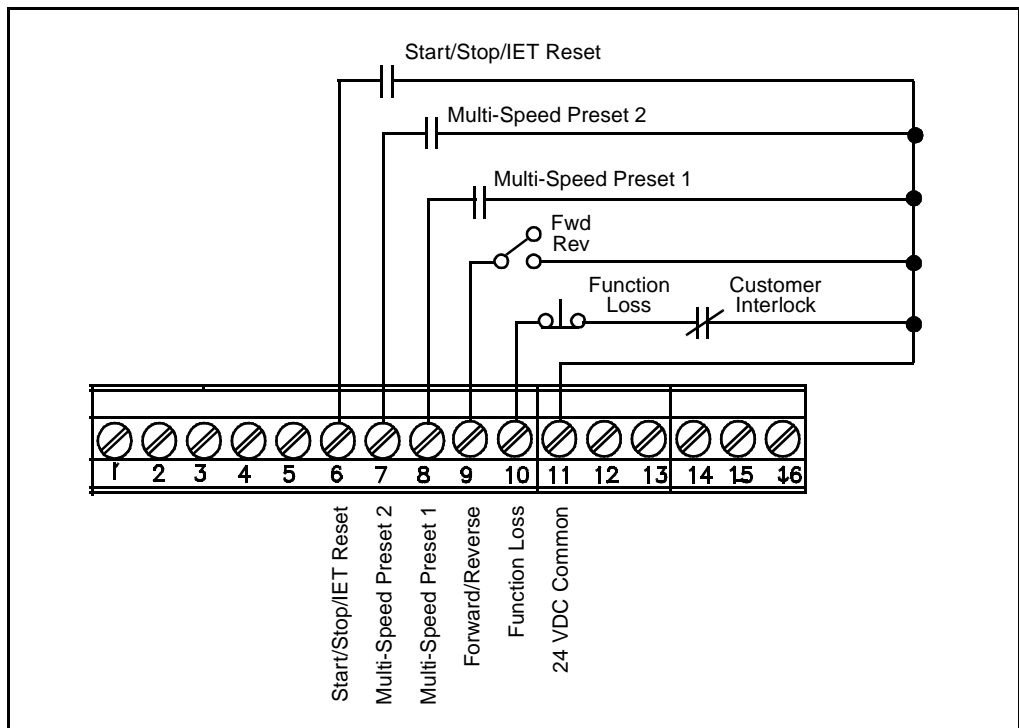

Figure 5.7 – Multi-Speed Preset Sample Control Wiring

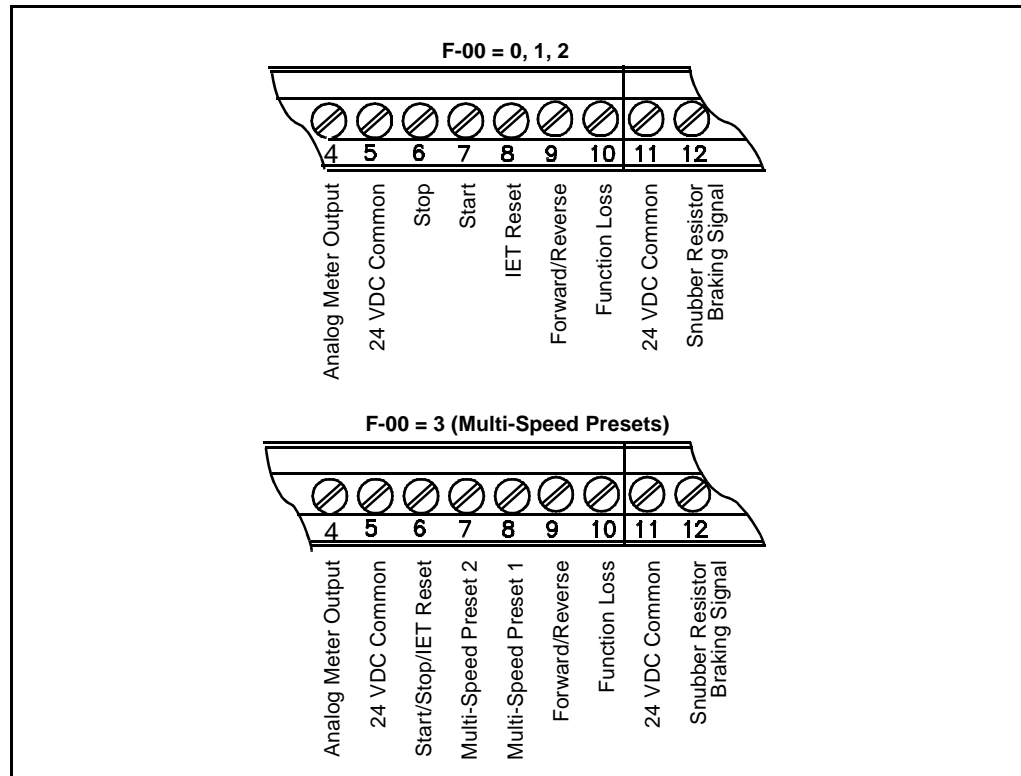

Figure 5.8 – Terminal Usage During Multi-Speed Preset Operation

### IET Reset Control Wiring

IET reset control wiring connects to terminals 8 and 11. See figures 5.5 and 5.6. Note that these reset wiring connections are not to be used in multi-speed preset applications. See figures 5.7 and 5.8.

### Forward/Reverse Control Wiring

Forward/reverse control wiring connects to terminals 9 and 11. See figures 5.5 through 5.7. Note that the setting of the forward/reverse switch is ignored when parameter F-17 is equal to 1 (disable reverse operation).

### Function Loss Control Wiring



**ATTENTION:** The user must provide an external, hardwired emergency stop circuit outside of the drive circuitry. This circuit must disable the system in case of improper operation. Uncontrolled machine operation may result if this procedure is not followed.

Function loss control wiring connects to terminals 10 and 11. See figures 5.5 through 5.7. Typically, a function loss input is a maintained, normally-closed pushbutton.

A signal must be present at terminal 10 for the drive to run. A factory-installed jumper connects terminals 10 and 11 which provides that signal. Remove this jumper if a function loss input, a coast-stop pushbutton, or another external interlock (for example, a motor thermostat) is used. Removing the jumper allows the drive to stop when the contact is open.

## 5.2.4 Snubber Resistor Wiring

Snubber resistor wiring connects to terminals 12 and 13 on the Regulator board's terminal strip. See figures 5.9 and 5.10.

Drive Model Number	Snubber Resistor Terminals	Control Terminal Strip Connections	Power Terminal Strip Connections
1SU2xxxx	1 (+) 2 (-)  147 (+) 45 (-)	12 13  N/A	N/A  (+) DC Bus (-) DC Bus
1SU4xxxx & 1SU5xxxx	1 (+) 2 (-)  147 (+) 45 (-)  13 (+) 14 (-)	12 13  N/A  N/A	N/A  (+) DC Bus (-) DC Bus  (+) 10V (-) 10 COM
1SU4x015 & 1SU4x020	Refer to instruction manual D2-3291.		



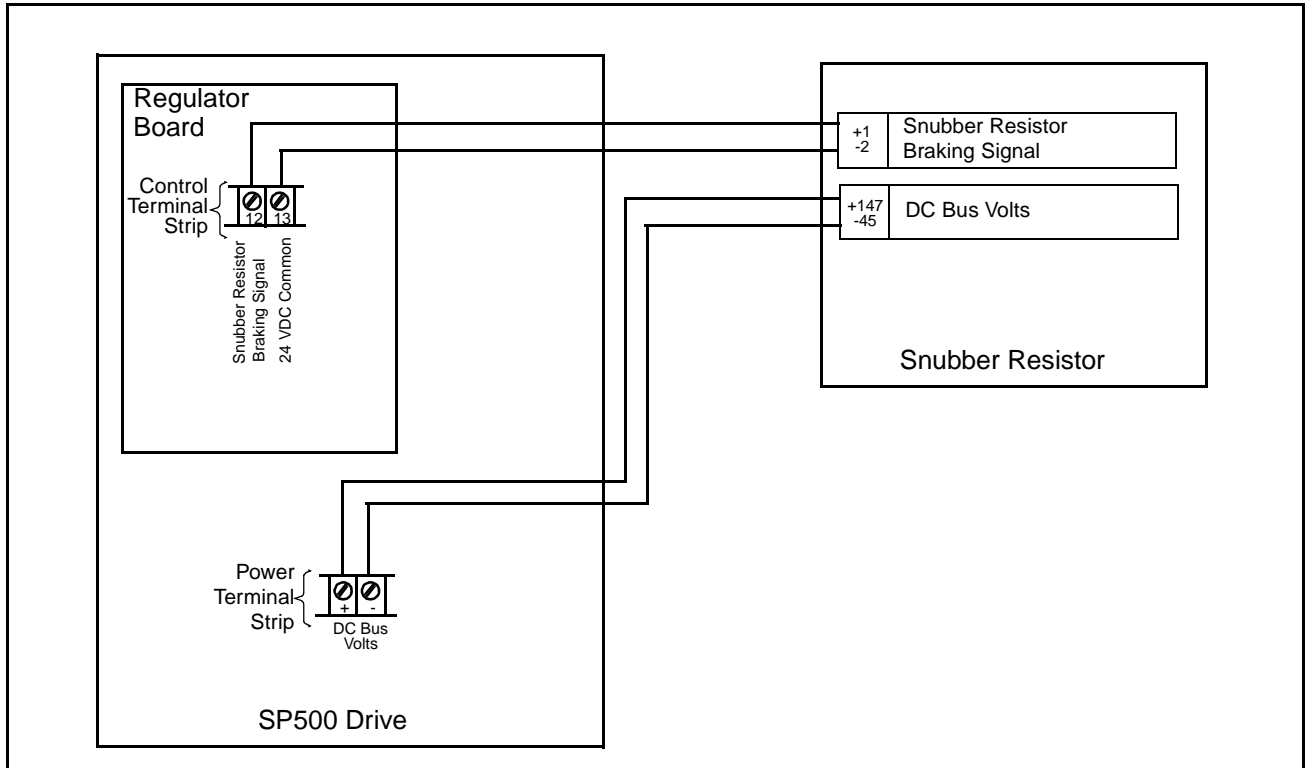

Figure 5.9 – Snubber Resistor Wiring Connections for M/N 1SU2xxxx Drives

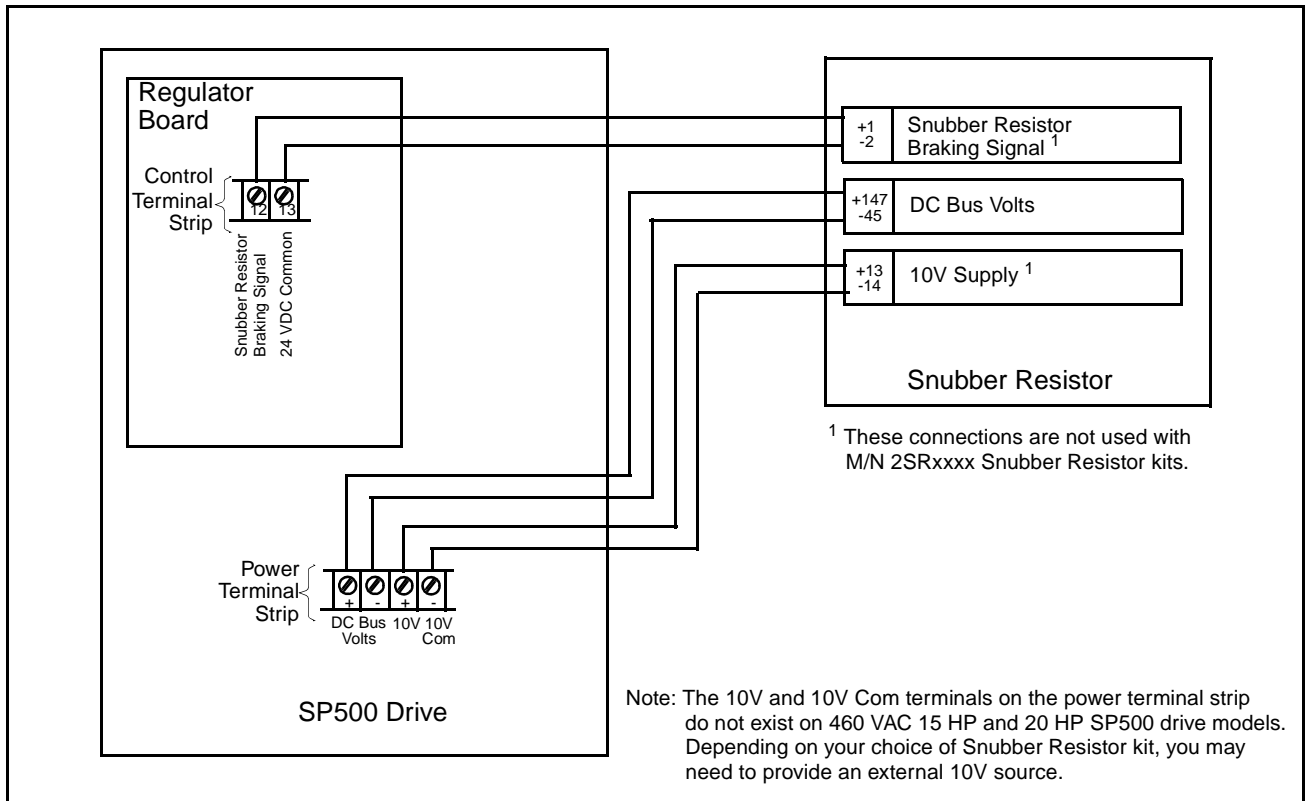

Figure 5.10 – Snubber Resistor Wiring Connections for M/N 1SU4xxxx and 1SU5xxxx Drives

## 5.2.5 Output Status Relay Wiring

Output status wiring connects to terminals 14 through 16 on the Regulator board's terminal strip. See figure 5.11. Parameter F-09 specifies the type of status indication provided by the output relay. See the F-09 parameter description in section 8.3 for more information.

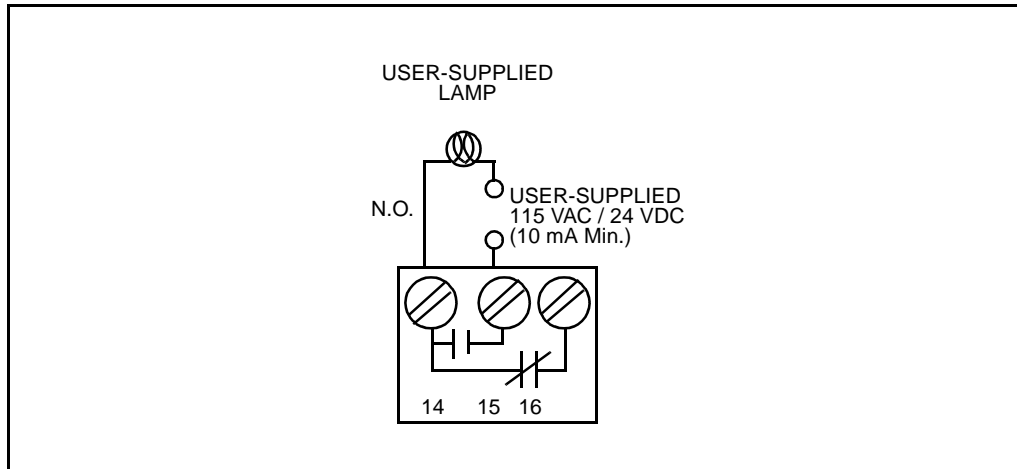

Figure 5.11 – Output Status Relay Wiring Connections

## 5.3 Output Power Wiring

Use the following steps to connect AC output power wiring from the drive to the motor:

Step 1. Wire the AC output power leads by routing them according to the type of enclosure. See figures 4.1 through 4.4. See tables 3.2 through 3.4 for recommended wire sizes.



**ATTENTION:** Do not route signal and control wiring with power wiring in the same conduit. This can cause interference with drive operation.

Do not route more than three sets of motor leads through a single conduit. This will minimize cross-talk which could reduce the effectiveness of noise reduction methods. If more than three drive/motor connections per conduit are required, you must use shielded cable. If possible, each conduit should contain only one set of motor leads.



**ATTENTION:** Unused wires in conduit must be grounded at both ends to avoid a possible shock hazard caused by induced voltages. Also, if a drive sharing a conduit is being serviced or installed, all drives using this conduit should be disabled to eliminate the possible shock hazard from cross-coupled motor leads.

Step 2. Connect the AC output power motor leads to terminals U, V, and W on the power terminal strip. See figure 5.1.

Step 3. Tighten terminals U, V, and W to the proper torque as shown in table 3.5.

## 5.4 Grounding



**ATTENTION:** The user is responsible for conforming with all applicable local, national, and international codes.

Use the following steps to ground the drive:

Step 1. Remove the drive's cover.

Step 2. Run a suitable equipment grounding conductor unbroken from the drive's ground terminal to the motor's ground terminal and then to earth ground. See figures 4.1 through 4.4 and 5.1.

Step 3. Connect a suitable grounding connector to the motor frame and transformer (if used). Run each conductor unbroken to earth ground.

When adding more than one grounding conductor wire to a single chassis ground, twist the conductors together.

Step 4. Reattach the drive's cover.



## Completing the Installation

This chapter provides procedures to check the installation.



**ATTENTION:** Only qualified electrical personnel familiar with the construction and operation of this equipment and the hazards involved should install, adjust, operate, and/or service this equipment. Read and understand this manual in its entirety before proceeding.

### 6.1 Checking the Installation With the Power Off



**ATTENTION:** DC bus capacitors retain hazardous voltages after input power has been disconnected. After disconnecting input power, wait five (5) minutes for the DC bus capacitors to discharge and then check the voltage with a voltmeter to ensure the DC bus capacitors are discharged before touching any internal components.

Perform the following checks of the drive installation with the power off:

- Step 1. Turn off, lock out, and tag the input power to the drive. Wait five minutes.
- Step 2. Check the DC bus potential with a voltmeter as described in section 9.1 to ensure that the DC bus capacitors are discharged.
- Step 3. If an input disconnect is installed, make sure it is in the off position.
- Step 4. Make sure the drive interlocks installed around the driven machine are operational.



**ATTENTION:** The user must provide an external, hardwired emergency stop circuit outside of the drive circuitry. This circuit must disable the system in case of improper operation. Uncontrolled machine operation may result if this procedure is not followed.

- Step 5. Verify that the user-installed stop pushbutton is wired correctly. Be sure the factory-installed jumper at terminals 10 and 11 has been removed so that the coast-stop pushbutton will work. (Refer to section 5.2.3.)



**ATTENTION:** Make sure electrical commons are not intermixed in the drive.

- Step 6. Remove any debris from around the drive.
- Step 7. Check that there is adequate clearance around the drive.
- Step 8. Verify that the wiring to the control terminal strip and power terminals is correct. Refer to chapter 5.

- Step 9. Check that the wire sizes are within terminal specifications and that the terminals are tightened to the appropriate torque specifications. Refer to tables 3.2 through 3.6.
- Step 10. Check that the user-supplied branch circuit protection is installed and correctly rated.
- Step 11. Check that the incoming AC power is rated correctly.
- Step 12. Check the motor installation and length of motor leads.
- Step 13. Disconnect any power correction capacitors connected between the drive and the motor.
- Step 14. Check that any motor thermal switch and the drive's electronic thermal overload are enabled (parameter F-15 = ON).
- Step 15. Check that the rating of the transformer (if used) matches the drive requirements and is connected for the proper voltage.
- Step 16. Verify that a properly-sized ground wire is installed and that a suitable earth ground is used. Check for and eliminate any grounds between the motor frame and the motor power leads. Verify that all ground leads are unbroken.
- Step 17. Uncouple the motor from any driven machinery to initially start the drive.

## 6.2 Checking Drive Operation



**ATTENTION:** DC bus capacitors retain hazardous voltages after input power has been disconnected. After disconnecting input power, wait five (5) minutes for the DC bus capacitors to discharge and then check the voltage with a voltmeter to ensure the DC bus capacitors are discharged before touching any internal components

Use the following procedure to check the operation of the drive:

- Step 1. Turn off, lock out, and tag power to the drive. Wait five minutes.
- Step 2. Remove the cover and check the DC bus potential with a voltmeter as described in section 9.1. Verify that the DC bus capacitors are discharged. Replace the cover.
- Step 3. Uncouple the driven equipment from the motor, if possible.
- Step 4. Apply power to the drive. SELF should be displayed for approximately 1 to 2 seconds to indicate internal diagnostics are being performed. After 1 to 2 seconds, 0 should be displayed and the LEDs should indicate drive status. If any fault codes are displayed, refer to chapter 9, Troubleshooting Reference.
- Step 5. Check all parameter settings and verify that they are set correctly based on the application. In most cases, the factory default values are adequate for this no-load start-up test. Parameters are described in chapter 8.
- Step 6. Press the START key. The drive should ramp at the acceleration rate (F-01) until it reaches the preset minimum speed (F-03).

- Step 7. Verify the direction of the motor shaft rotation. If it is incorrect for your application, use the following procedure to change the direction of rotation. If it is correct, go to step 8.
- Press the STOP/RESET key to stop the drive.
  - Wait until the motor has completely stopped.
  - Turn off, lock out, and tag power to the drive. Wait five minutes.
  - Remove the cover and check the DC bus potential with a voltmeter as described in section 9.1. Verify that the DC bus capacitors are discharged. Replace the cover.
  - Reverse any two of the three motor power leads (U, V, or W).
  - Turn the power on.
  - Press the START key and verify the direction of rotation.
- Step 8. Using the ▲ and ▼ keys, run the motor without any load across the speed range. If the motor does not operate satisfactorily, check the parameter settings. Refer to chapter 8.
- Step 9. Press the STOP/RESET key to stop the drive.
- Step 10. Turn off, lock out, and tag power to the drive. Wait five minutes. Remove the cover and check the DC bus potential with a voltmeter as described in section 9.1. Verify that the DC bus capacitors are discharged. Replace the cover.
- Step 11. Couple the driven equipment to the motor.
- Step 12. Turn power on.
- Step 13. Press the START key.
- Step 14. Run the drive across the required speed range under load. If the motor does not rotate at minimum speed, increase the manual torque boost (F-06).
- Step 15. If the drive operates the motor properly, go to step 16. If the drive does not operate the motor properly, follow the steps below:
- Refer to chapter 9, Troubleshooting Reference, if any fault codes were displayed during start up.
  - Verify the parameter settings again.
- Step 16. If the drive operates the motor properly:
- Press the STOP/RESET key to stop the drive.
  - Record the parameter settings in Appendix B.





## Keypad and Display Operation

The front-panel keypad and display, shown in figure 7.1, are used to program, monitor, and control the drive. They operate in two modes: monitor mode and program mode.

In monitor mode (the default mode), you can monitor specific drive outputs and the drive's speed reference.

In program mode, you can view and adjust drive parameter values and examine the error log.

In addition to the functions above, if the control source is local (F-00 = 0), you use the keypad to start and stop the drive, select motor direction, and adjust speed.

Regardless of the control source selected, you can use the keypad to stop the drive and reset drive faults.

The following sections describe the keypad, the display, and the LEDs. Monitor mode and program mode are described in more detail later in this chapter.

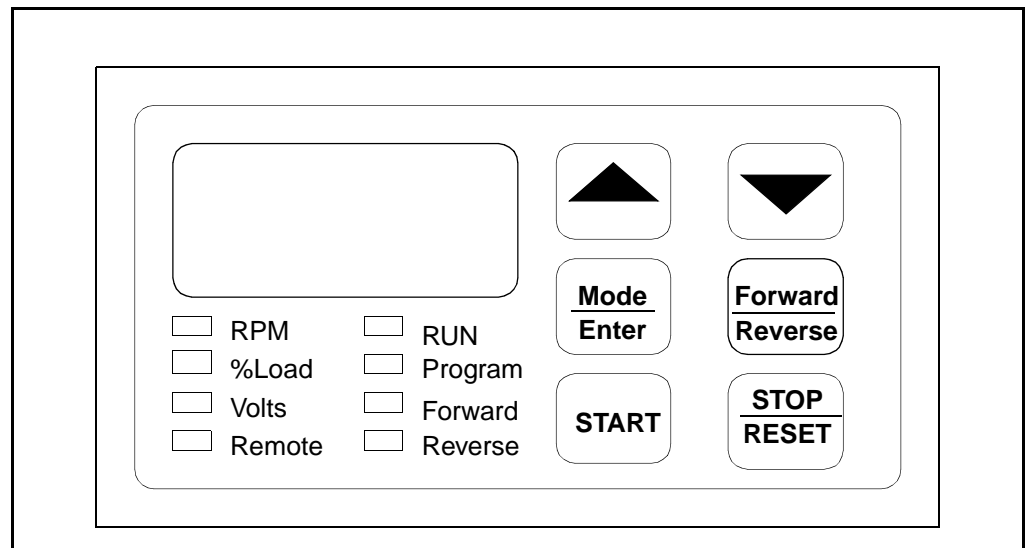

Figure 7.1 – SP500 Keypad and Display





### 7.1 Display Description

The display is a four-character, seven-segment LED. At drive power up, SELF is displayed while the drive performs power-up diagnostics. During drive operation, the display indicates parameter numbers, parameter values, fault codes, and drive output values. Figures 7.3 and 7.4 show sample displays.

## 7.2 Key Descriptions

The keypad's six membrane keys are used to monitor, program, and control the drive. Table 7.1 describes the keys.

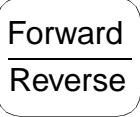
Table 7.1 – Key Descriptions

 	<p>Use the UP and DOWN arrow keys to:</p> <ul style="list-style-type: none"> <li>• Step through the drive parameters and error log when the drive is in program mode.</li> <li>• Increase or decrease a parameter's numeric value or status in program mode.</li> <li>• Increase or decrease the internal speed reference when F-00 (Control Source Select) = 0 or 2.</li> </ul> <p>Hold down these keys to increase the scroll speed.</p>
	<p>Use the MODE/ENTER key to:</p> <ul style="list-style-type: none"> <li>• Advance through each monitor display item in monitor mode.</li> <li>• Select program mode when the drive is stopped.</li> <li>• Display a parameter value in program mode.</li> <li>• Save a parameter value in program mode.</li> </ul> <p>The MODE/ENTER key provides these functions regardless of the control source selected (local or remote).</p>
	<p>Use the FORWARD/REVERSE key to select the direction of motor shaft rotation when the control source is local (F-00 = 0).</p>
	<p>Use the START key to apply power to the motor when the control source is local (F-00 = 0).</p> <p>When this key is pressed, and there are no active faults, the drive will accelerate to the last programmed frequency setpoint (speed).</p>
	<p>Use the STOP/RESET key to:</p> <ul style="list-style-type: none"> <li>• Turn off the drive output to the motor if the drive is running.</li> <li>• Clear drive faults when the drive is in program mode.</li> <li>• Exit program mode.</li> </ul> <p>When this key is pressed, the drive will ramp to rest at a user-defined rate (user option) or coast to rest (default). This key stops the drive regardless of the selected control source (remote or local).</p>

## 7.3 LED Descriptions

The keypad area contains eight LEDs that indicate either drive status or which drive output value is displayed in monitor mode. Tables 7.2 and 7.3 describe the drive status LEDs and monitor mode LEDs, respectively.

Table 7.2 – Drive Status LED Descriptions

LED	State	Description
■ Run	On	The drive is generating an output voltage and frequency.
	Off	The drive is not generating an output voltage and frequency.
	<b>ATTENTION:</b> The RUN LED must not be used as an indication that there is no line voltage present in the drive. Verify there is no voltage present at the DC bus terminals (+) and (-) before servicing the drive. Failure to observe this precaution could result in severe bodily injury or loss of life.	
■ Program	On	The keypad and display are in program mode.
	Off	The keypad and display are in monitor mode.
■ Forward	On	The requested motor rotation direction is forward.
	Off	The requested motor rotation direction is not forward.
■ Reverse	On	The requested motor rotation direction is reverse.
	Off	The requested motor rotation direction is not reverse.
■ Remote	On	The drive is being controlled from the terminal strip.
	Off	The drive is being controlled from the keypad.

Table 7.3 – Monitor Mode LED Descriptions

LED	Corresponding Display When LED is On (Actual Value)
■ RPM/Engineering Unit	Motor speed in RPM or in a user-specified engineering unit. (Refer to the F-08 parameter description for more information).
■ %Load	Percentage of drive full load amps rating.
■ Volts	Drive output voltage to the motor.
All LEDs (RPM, Volts, %Load)	Value of the active speed reference signal as 0 to 100% of the total scaled reference range. F-13 must be set to ON to display this value. (Refer to the F-13 parameter description for more information).

## 7.4 Program Mode

Program mode allows you to display and modify drive parameter values when the drive is stopped.

The following can be displayed in program mode:

- Parameter numbers
- Parameter values
- Error log information

### To enter program mode:

Step 1. Stop the drive (if it is running) by pressing the STOP/RESET key.

Step 2. Press the MODE/ENTER key until the PROGRAM LED turns on.

Parameter F-00 will be displayed. Use the ▲ key or ▼ key to scroll through the parameter list. The error log follows parameter F-49 and precedes parameter F-00 as shown in figure 7.2.

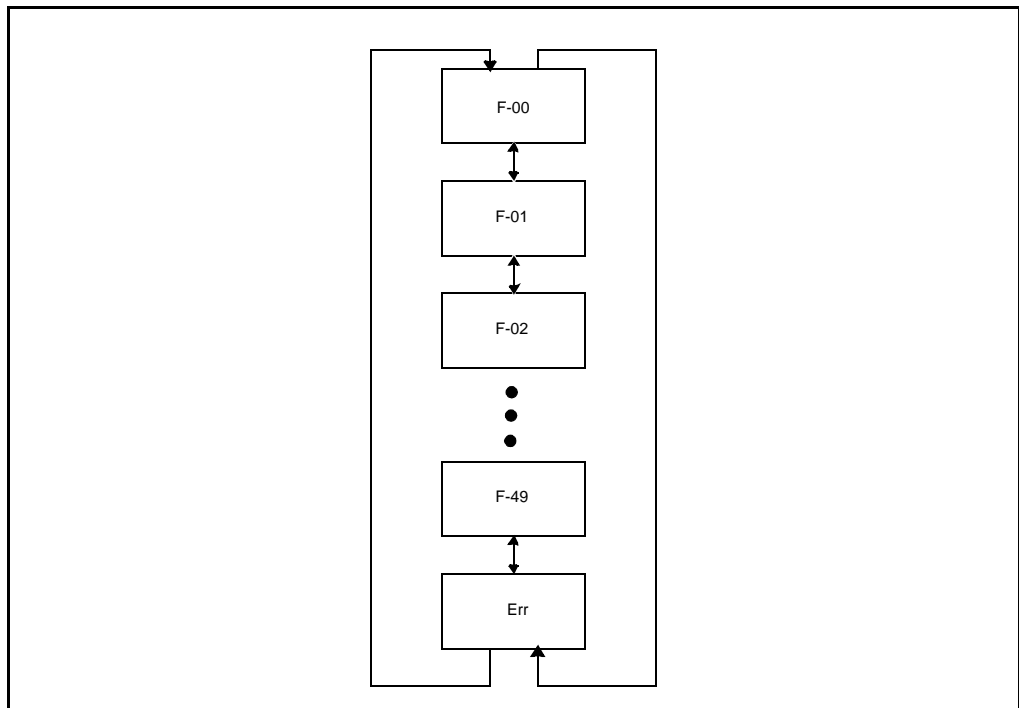

Figure 7.2 – SP500 Menu Structure

### To exit program mode:

Step 1. Press the MODE/ENTER key until a parameter number or ERR is displayed.

Step 2. Press the STOP/RESET key until the PROGRAM LED turns off.

**Important:** Pressing the STOP/RESET key while you are examining the error log clears the log.

A sample program mode display is shown in figure 7.3.

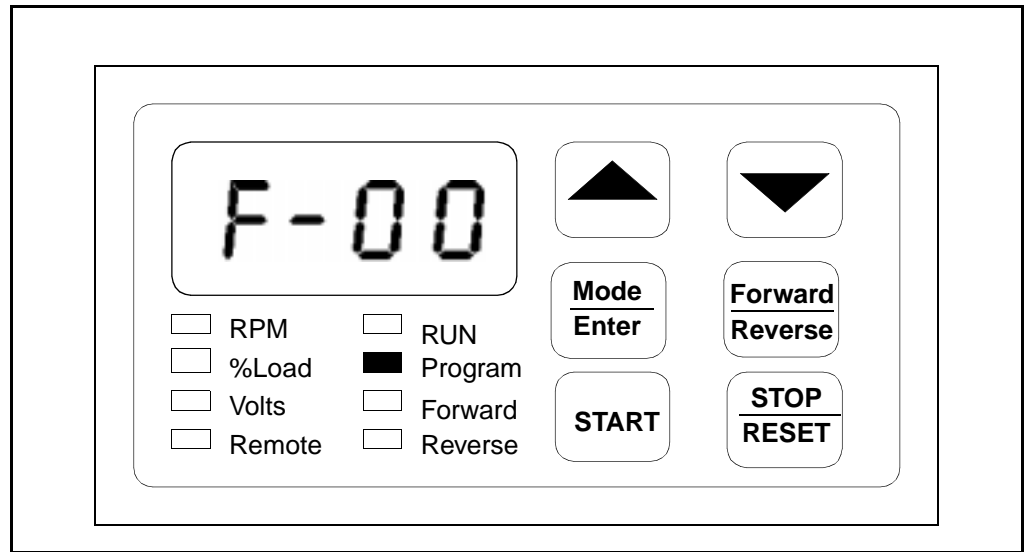

Figure 7.3 – Example of a Program Mode Display

For information about:	Refer to section:
Displaying or changing parameter values	8.1
Ensuring program security	8.2
Individual parameters	8.3
Accessing the error log	9.4

## 7.5 Monitor Mode

Monitor mode is the keypad and display's default mode of operation (in other words, the keypad and display will return to monitor mode when you exit program mode). The keypad and display must be in monitor mode before the drive can be put into run (RUN LED is on) and will remain in monitor mode while the drive is running.

The following output data can be displayed in monitor mode:

- RPM
- %Load
- Volts
- Percent Selected Speed Reference (if F-13 = ON)

To select a value to monitor, press the MODE/ENTER key until the LED turns on next to the desired display item. Pressing the MODE/ENTER key will advance you through each of the displays. (Note that all the LEDs will turn on to indicate the percent selected speed reference display if parameter F-13 is set to ON. Refer to section 7.5.2.)

A sample monitor mode display is shown in figure 7.4.

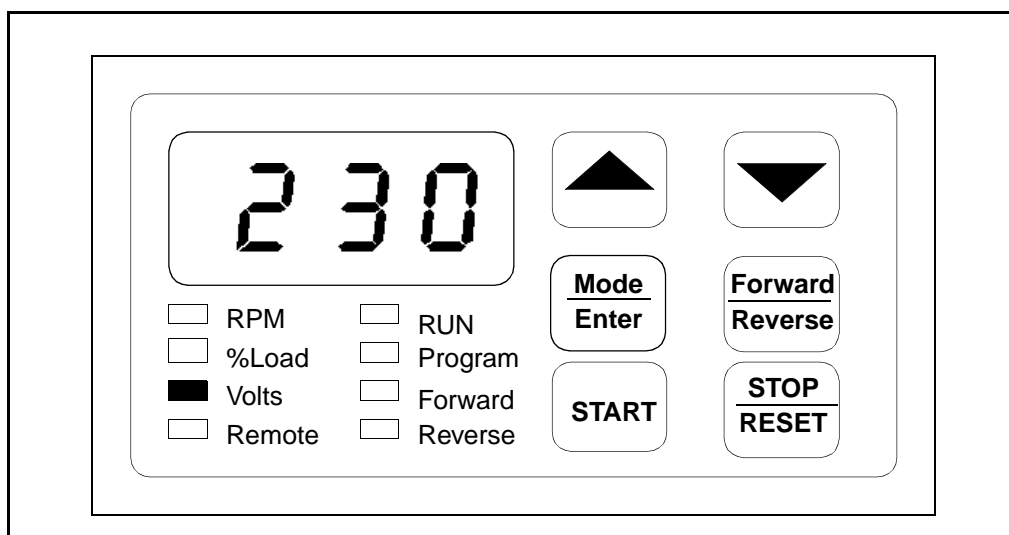

Figure 7.4 – Example of a Monitor Mode Display

### 7.5.1 Displaying the Percent Selected Speed Reference

To display the percent selected speed reference, parameter F-13 must be set to ON. Use the following procedure to display the percent selected speed reference:

- Step 1. Stop the drive (if it is running) by pressing the STOP/RESET key.
- Step 2. Enter program mode by pressing the MODE/ENTER key until the PROGRAM LED turns on.
- Step 3. Press the ▲ or ▼ key until F-13 is displayed.
- Step 4. Press the MODE/ENTER key to access the parameter.
- Step 5. Press the ▲ key until ON is displayed.
- Step 6. Press the MODE/ENTER key to save the value. (F-13 will be displayed.)
- Step 7. Press the STOP/RESET key to exit program mode.
- Step 8. Start the drive by pressing the START key.
- Step 9. Press the MODE/ENTER key until all three monitor mode LEDs are on.

The display will show the active speed reference as 1 to 100% of maximum speed (F-04).

### 7.5.2 Scaling the RPM Display and Reference Using F-08

The RPM display and reference can be scaled to an engineering unit to match your application. Refer to the F-08 description in chapter 8 for this procedure.

## 7.6 Drive Control

When the control source is the local keypad (F-00 = 0), the keypad is used to control the drive. This means that the drive will respond to START, STOP/RESET, and FORWARD/REVERSE commands only from the keypad.

The functions of the keypad keys are described in section 7.2. Refer to the F-00 Control Source Select parameter description in chapter 8 for more information on selecting a drive control source.

### 7.6.1 Changing the Reference Using the Keypad

The speed reference can be increased or decreased using the ▲ or ▼ key when F-00 = 0 or 2. The display will show the internal speed reference in hertz (Hz) while the keys are pressed. There will be a slight delay before the display returns to the active monitor mode.

Note that changing the drive's internal speed reference using the ▲ or ▼ key when the drive is under remote control will have no operational effect on the drive (unless F-00 = 2).





## Programming Reference

To program the SP500 drive for a specific application, you display the appropriate parameter and adjust it as required. The parameters specify characteristics of the drive. This chapter describes how to access, display, and modify parameters. Section 8.3 describes each parameter in detail. Appendix C lists the parameters in alphabetical order.

### 8.1 Displaying or Changing Parameter Values

Use the following procedure to display or change parameter values:

Step 1. Stop the drive (if it is running) by pressing the STOP/RESET key.

Step 2. Enter program mode by pressing the MODE/ENTER key until the PROGRAM LED turns on.

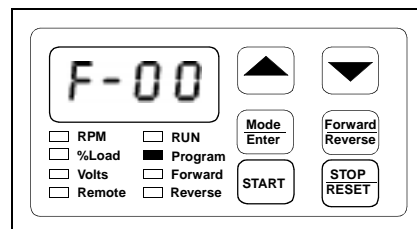

The first parameter number (F-00) will be displayed.

Step 3. Press the ▲ or ▼ key until the desired parameter number is displayed.

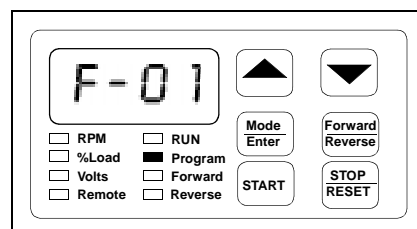

Each parameter number will be displayed as you scroll through the parameter list.

---

Step 4. Press the MODE/ENTER key to display the parameter value.

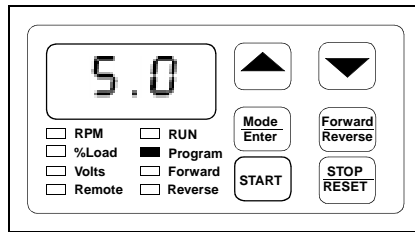

---

Step 5. Press the ▲ or ▼ key to change the value.

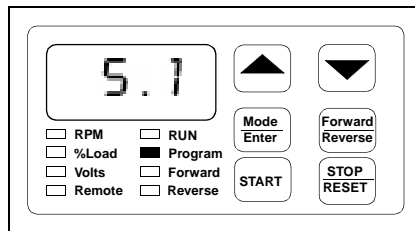

Note that if programming has been disabled in parameter F-20 (Password Lockout Enable), the value will not change. Refer to section 8.2, Ensuring Program Security, for more information.

---

Step 6. Press the MODE/ENTER key to save the changed value.

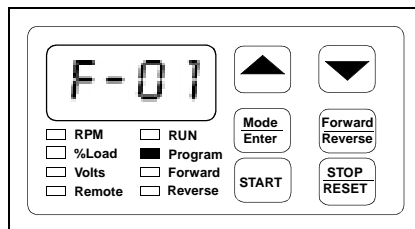

The parameter number is displayed again.

---

**To display or change additional parameters,** repeat steps 3 through 6.

**To exit program mode,** press the MODE/ENTER key until a parameter number or ERR is displayed; then press the STOP/RESET key.

**Important:** Parameter values and the keypad status (local or remote) are retained through a line dip or power loss.

## 8.2 Ensuring Program Security



**ATTENTION:** It is the user's responsibility to determine how to distribute the password. Reliance Electric is not responsible for unauthorized access violations within the user's organization.

Parameter values can be password-protected using parameter F-20 (Password Lockout Enable). When F-20 is set to ON, parameter values can be displayed but cannot be modified from the keypad unless the correct password is entered in F-20.

**Important:** The password is factory set to 257 and cannot be modified by the user.

Use the following procedure to disable or enable parameter programming:

Step 1. In program mode, press the ▲ or ▼ key until F-20 is displayed.

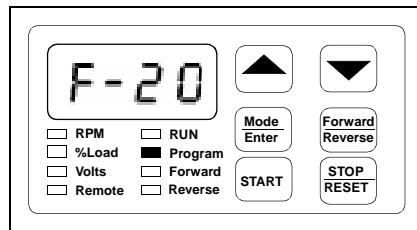

Step 2. Press the MODE/ENTER key to access the parameter. ON or OFF is displayed to indicate whether the password lockout feature is currently enabled or disabled.

Program Enabled

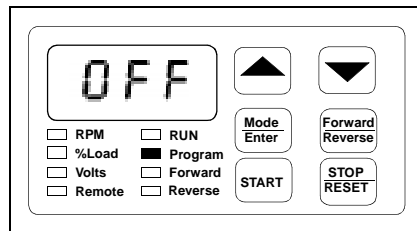

Program Disabled

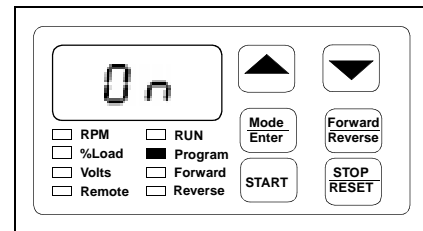

---

Step 3. Press the ▲ key until the password number, 257, is displayed. (Holding down the ▲ key increases the scroll speed.)

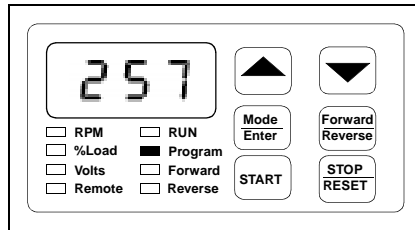

---

Step 4. Press the MODE/ENTER key to save the password number.

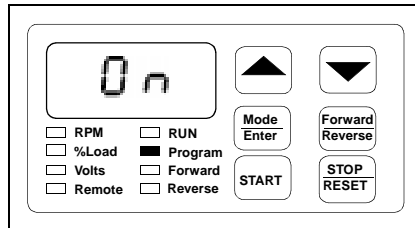

ON or OFF is displayed to indicate the current state of the password lockout.

---

Step 5. Press the MODE/ENTER key to exit the parameter.

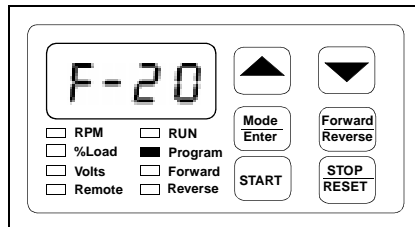

The parameter number is displayed again.

---

**Important:** There is no visual indication of the status of this feature. You must access F-20 to verify its current value (ON or OFF).

## 8.3 Parameter Descriptions

---

### F-00 Control Source Select

This parameter selects the drive control source and speed reference source.

<b>Parameter Range:</b>	0 = Local control; control signals and speed reference from the keypad
	1 = Remote control; control signals from the terminal strip; speed reference from the analog input
	2 = Remote control; control signals from the terminal strip; speed reference from the keypad
	3 = Remote control; control signals from the terminal strip; multi-speed presets from the terminal strip
<b>Default Setting:</b>	0 = Local control
<b>Step Size:</b>	N/A

When F-00 = 0, the drive responds to sequencing commands (start, stop, forward, reverse) from only the keypad.

When F-00 = 1, 2, or 3, the drive responds to sequencing commands from the terminal strip. Note that the drive will respond to the stop command from the keypad regardless of the value in this parameter.

Refer to the F-23 to F-25 Multi-Speed Presets parameter description for more information about multi-speed presets.

---

### F-01 Acceleration Time

This parameter specifies the amount of time it takes the motor to ramp from stop to the maximum speed setting in F-04.

<b>Parameter Range:</b>	0.5 to 90 seconds
<b>Default Setting:</b>	5.0 seconds
<b>Step Size:</b>	0.10 seconds

If the setpoint frequency requested from the keypad (using the ▲ and ▼ keys) is less than the maximum speed setting, the time to ramp to that frequency will be proportionally less than the actual rate setting. For example, if F-04 = 60Hz and F-01 = 4 seconds, it will take 2 seconds to ramp to a frequency reference of 30 Hz.

Note that if the acceleration rate is set too fast, an overcurrent fault may occur (OC will be displayed).

---

### F-02 Deceleration Time

This parameter specifies the amount of time it takes the motor to ramp from the maximum speed setting in F-04 to a stop.

<b>Parameter Range:</b>	0.5 to 90 seconds
<b>Default Setting:</b>	5.0 seconds
<b>Step Size:</b>	0.10 seconds

## F-02 Deceleration Time *(continued)*

If the frequency requested from the keypad (using the ▲ and ▼ keys) is less than the maximum speed setting, the time to ramp to that frequency will be proportionally less than the actual rate setting. For example, if F-04 = 60Hz and F-02 = 4 seconds, it will take 2 seconds to ramp to a frequency reference of 0Hz from 30 Hz.

Note that if the deceleration rate is set too fast, a high bus fault may occur (HU will be displayed)

---

## F-03 Minimum Speed

This parameter limits the speed reference to the drive. Regardless of what speed reference is supplied, the regulator will not command a speed less than the value in F-03.

<b>Parameter Range:</b>	0.5 to 30 Hz
<b>Default Setting:</b>	5.0 Hz
<b>Step Size:</b>	0.10 Hz if F-04 < 100 Hz 0.25 Hz if F-04 ≥ 100 Hz



**ATTENTION:** The SP500 drive is intended to operate the motor at a predetermined minimum speed unless disconnected from the power source. The user is responsible for assuring safe conditions for operating personnel by providing suitable guards, audible or visual alarms, or other devices to indicate that the drive is operating at minimum speed, (possibly zero speed), or the user must verify that the motor output shaft will rotate at all combinations of load and output speed required by the application.

---

## F-04 Maximum Speed

This parameter limits the speed reference to the drive. Regardless of what speed reference is supplied, the regulator will not command a speed greater than the value in F-04.

<b>Parameter Range:</b>	30 to 240 Hz
<b>Default Setting:</b>	60 Hz
<b>Step Size:</b>	0.10 Hz if F-04 < 100 Hz 0.25 Hz if F-04 ≥ 100 Hz



**ATTENTION:** The user is responsible for ensuring that driven machinery, all drive-train mechanisms, and process line material are capable of safe operation at maximum speed (F-04). Failure to observe this precaution could result in bodily injury.

## F-05 Current Limit

This parameter limits motor output torque while it is running or accelerating.

<b>Parameter Range:</b>	10% to 150% of rated drive current
<b>Default Setting:</b>	150%
<b>Step Size:</b>	1.0%

When output current attempts to exceed the preset current limit, motor current will be maintained or reduced, or the acceleration / deceleration time will be extended. If current limit is set too low or too high relative to the required load, an overcurrent fault may occur (OC will be displayed).

## F-06 Manual Torque Boost

This parameter sets the percentage of output voltage boost at zero frequency.

<b>Parameter Range:</b>	0 to 10%
<b>Default Setting:</b>	2%
<b>Step Size:</b>	1%

Torque boost offsets the voltage drop of the AC motor at low speeds. For high friction loads or high inertia loads, a high starting torque level may be needed. Manual torque boost is only effective at speeds lower than one-half of the motor's base frequency. See figure 8.1.

When adjusting this parameter, start with the default setting of 2% and gradually increase the value until motor operation is satisfactory. If torque boost is set too high relative to the load and acceleration rate, an overcurrent fault may occur (OC will be displayed).

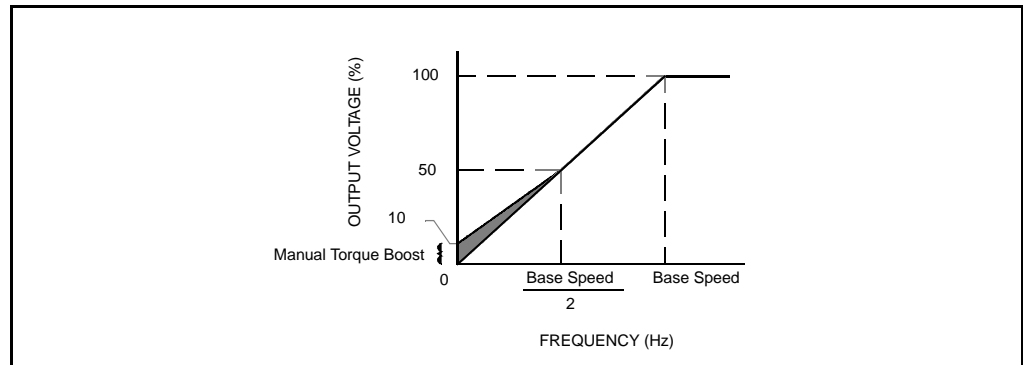

Figure 8.1 – Manual Torque Boost Adjustment Range

## F-07 V/Hz (Base Speed)

This parameter specifies the base speed at maximum output voltage and is used to establish the volts/hertz (V/Hz) curve.

<b>Parameter Range:</b>	30 to 240 Hz
<b>Default Setting:</b>	60 Hz
<b>Step Size:</b>	1.0 Hz

## F-07 V/Hz (Base Speed) (continued)

The V/Hz curve allows the drive to maintain a constant V/Hz ratio, providing constant torque at any frequency. See figure 8.2.

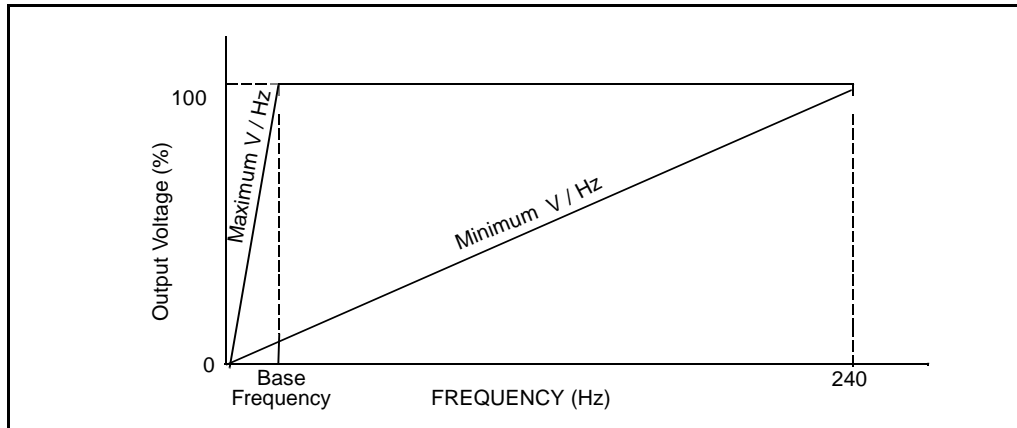

Figure 8.2 – Volts/Hertz Curve

## F-08 RPM at Base Speed

This parameter scales the RPM display and the setpoint to a user-specified engineering unit.

<b>Parameter Range:</b>	10 to 9999
<b>Default Setting:</b>	1750
<b>Step Size:</b>	1.0 unit

This parameter defines the scaling value applied to the current speed before it is displayed. It is also used to scale the local reference when F-18 is set to ON.

The value to enter into F-08 is the maximum value (in RPM, hertz, or any other engineering unit) to be displayed when the drive is running at base speed (F-07).

### Display Scaling Examples

**Example 1:** Assume that an application requires the display show 1750 RPM when the drive is running at a base speed of 60 Hz. The RPM display is scaled according to the following equation:

$$\text{Present Operating Speed (Hz)} \times \frac{\text{F-08}}{\text{F-07}} = \text{Displayed Value}$$

At 30 Hz, the RPM display will show 875:

$$30 \text{ (Hz)} \times \frac{1750}{60} = 875$$

**Example 2:** Assume the application requires the display show 20 feet per minute for a conveyor (or 20 gallons per minute for a pump) when the motor is running at base speed (F-07= 60 Hz). Enter 20 in parameter F-08 to scale the display.

At 30 Hz, the display will show 10 feet (or gallons) per minute:

$$30 \text{ (Hz)} \times \frac{20}{60} = 10$$



---

## F-09 Configurable Output Relay Select

This parameter specifies the type of status indication the output relay contacts provide (terminals 14, 15, and 16 on the drive terminal strip).

<b>Parameter Range:</b>	0 = Output relay is energized to show state of drive running. 1 = Output relay is energized to show state of active fault (IET). 2 = Output relay is energized to show state of drive running at speed.
<b>Default Setting:</b>	0
<b>Step Size:</b>	N/A

If F-09 = 0, the output is energized only when the RUN LED is on.

If F-09 = 1, the output remains energized until the fault is cleared by pressing the STOP/RESET key (in local operation) or by using the remote IET reset signal (for remote operation).

If F-09 = 2, the output is energized when the drive is running and at speed.

---

## F-10 Carrier Frequency

This parameter selects the drive's carrier frequency.

<b>Parameter Range:</b>	4 = 4 kHz Carrier frequency 6 = 6 kHz Carrier frequency 8 = 8 kHz Carrier frequency
<b>Default Setting:</b>	4
<b>Step Size:</b>	N/A

The carrier frequency controls the width of the pulse and keeps the current smooth to the motor. This parameter can compensate for acoustic noise, heating, and other current problems by adjusting the switching frequency of the transistors in the inverter section.

Keeping the carrier frequency at 4kHz maximizes the continuous power rating of the drive with, generally, an acceptable acoustic noise level from the motor. Increasing the carrier frequency reduces the acoustic noise, but in some applications this can result in derating of the drive output amps. (Refer to table 2.2 for the derated ratings at the various carrier frequencies).

---

## F-11 Remote Reference Gain

This parameter scales the maximum remote speed reference to match external equipment.

<b>Parameter Range:</b>	60% to 100% of full scale maximum reference
<b>Default Setting:</b>	100%
<b>Step Size:</b>	0.10%

Normally, the maximum speed reference (the amount of reference at maximum speed, F-04) is either 10 VDC or 20 mA. The reference gain is used to scale the speed reference to another value (for example, 9.5 VDC or 19 mA). Enter the parameter value in percent of full scale reference.

## F-11 Remote Reference Gain (continued)

To calculate the scaled reference if you are using a **0 to 20 mA remote reference**, use the following equation:

$$\frac{\text{Desired Maximum Reference (mA)}}{\text{Reference Range (20)}} \times 100 = \% \text{ gain (mA reference)}$$

### Example

If the remote speed reference is 0 to 20 mA and the maximum reference required is 19.2 mA, scale as follows:

$$\frac{19.2}{20} \times 100 = 96\% \text{ gain}$$

To calculate the scaled reference if you are using a **0 to 10 VDC remote reference**, use the following equation:

$$\frac{\text{Desired Maximum Reference (VDC)}}{\text{Reference Range (10)}} \times 100 = \% \text{ gain (VDC reference)}$$

### Example

If the remote speed reference is 0 to 10VDC and the maximum reference required is 9.5 VDC, scale as follows:

$$\frac{9.5}{10} \times 100 = 95\% \text{ gain}$$

---

## F-12 Remote Reference Offset

This parameter scales the remote speed reference (0 to 10VDC or 0 to 20 mA) to a minimum value.

<b>Parameter Range:</b>	0% to 40% of full scale minimum reference
<b>Default Setting:</b>	0%
<b>Step Size:</b>	0.10%

Typically, the value of the minimum speed reference (the amount of reference at minimum speed, F-03) is either 0 VDC or 0 mA. Enter the parameter value as a percentage of the full scale reference to be offset from minimum speed.

To calculate the scaled minimum reference, use the following equation:

$$\frac{\text{Desired Minimum Speed Offset}}{\text{Reference Range}} \times 100 = \% \text{ offset}$$

### Scaling Examples

**Example 1:** If the remote analog input speed reference is 0 to 20 mA (J6 set on terminals 2 and 3), and the available analog reference signal is 4 to 20 mA, use F-12 to obtain minimum speed with minimum analog input as follows:

$$\frac{4}{20} \times 100 = 20\% \text{ offset}$$

**Example 2:** If the remote analog input speed reference is 0 to 10 VDC (J6 set on terminals 1 and 2), and the available signal is offset 0.4 VDC, use F-12 to obtain minimum speed with minimum analog input as follows:

$$\frac{0.4}{10} \times 100 = 4\% \text{ offset}$$

---

## F-13 Percent Selected Speed Reference Display Enable

This parameter enables or disables the fourth monitor mode display.

<b>Parameter Range:</b>	ON = Fourth monitor mode display is enabled. OFF = Fourth monitor mode display is disabled.
<b>Default Setting:</b>	OFF
<b>Step Size:</b>	N/A

If F-13 = ON, the current value of the active speed reference can be displayed by pressing the MODE/ENTER key (while the drive is running) until all three monitor mode LEDs are on. The active speed reference is displayed as 1 to 100% of maximum speed (F-04).

If F-13 = OFF, the active speed reference will not be displayed.

Refer to chapter 3 for more information on the monitor mode displays.

---

## F-14 Electronic Thermal Overload

This parameter sets the trip level for the electronic thermal overload fault (OL) when F-15 = ON.

<b>Parameter Range:</b>	20% to 100% rated current
<b>Default Setting:</b>	100%
<b>Step Size:</b>	1%

This parameter should be adjusted if the motor current rating is less than the drive current rating.

Use the formula below to calculate the setting level as a percentage of maximum continuous current:

$$F-14 = \frac{\text{Motor Full Load Current}}{\text{Drive Output Rated Current}} \times 100$$

The motor full load current value can be found on the motor nameplate. See table 2.2 or the drive nameplate for the drive rated output value.

---

## F-15 Electronic Thermal Overload Enable

This parameter enables or disables the electronic motor thermal overload function. This function operates like a motor thermal switch to protect the motor from overheating.

<b>Parameter Range:</b>	OFF = No electronic thermal overload protection. ON = Electronic thermal overload protection is active.
<b>Default Setting:</b>	ON
<b>Step Size:</b>	N/A



**ATTENTION:** Parameter F-15 should be set to ON to prevent damage to the motor and the drive.

## F-15 Electronic Thermal Overload Enable *(continued)*

When F-15 = ON, the drive faults if it exceeds the thermal overload time (60 seconds at 150% of F-14). When an external thermal switch or other overtemperature monitoring device is connected to the function loss circuit (terminals 10 and 11), this parameter may be set ON or OFF.

For multi-motor applications, set this parameter to OFF. The individual motors must have thermal switch protection.

---

## F-16 Coast Stop Enable

This parameter selects how the motor will stop when given a stop command.

<b>Parameter Range:</b>	ON = Enable coast stop (motor will coast to rest) OFF = Disable coast stop (motor will ramp to rest)
<b>Default Setting:</b>	OFF
<b>Step Size:</b>	1%



**ATTENTION:** The user must provide an external, hardwired emergency stop circuit outside of the drive circuitry. This circuit must disable the system in case of improper operation. Uncontrolled machine operation may result if this procedure is not followed.

A coast-to-rest stop turns off the transistor power device drivers. A ramp-to-rest stop fires the transistor power device drivers until the motor comes to a stop and then turns off the power device drivers.

Note that the function loss input opening or a drive fault will always cause a coast-to-rest stop.

---

## F-17 Reverse Disable

This parameter enables or disables reverse rotation of the motor.

<b>Parameter Range:</b>	ON = Disable reverse OFF = Enable reverse
<b>Default Setting:</b>	OFF
<b>Step Size:</b>	N/A

If F-17 = OFF, the forward/reverse input allows forward or reverse rotation of the motor.

If F-17 = ON, reverse rotation of the motor is prohibited. When F-17 = ON, pressing the FORWARD/REVERSE key on the keypad in local control, or wiring to terminal 9 on the terminal strip in remote control, does not affect drive operation.

---

## F-18 RPM Setpoint Enable

The parameter enables the setpoint to be displayed in F-08 units.

<b>Parameter Range:</b>	OFF = Setpoint is displayed in hertz. ON = Setpoint is displayed in the units specified in F-08.
<b>Default Setting:</b>	ON
<b>Step Size:</b>	N/A

If F-18 = ON, pressing the ▲ and ▼ keys will change the setpoint in units of 1 between minimum speed in F-08 units and maximum speed in F-08 units. Note that this parameter only affects the setpoint, not the display.

### Example

Assume a drive is currently running at 60 Hz = 1750 RPM, F-08 = 1750, and F-10 = ON. When the ▼ key is pressed, 1750 is displayed. When the ▼ key is pressed three more times, the display will change from 1750 to 1749 to 1748 to 1747. The reference is then rescaled based on this input:

$$\text{Input Reference} = \frac{\text{Reference (1747)}}{\text{F-08 (1750)}} \times \text{F-04 (60 Hz)} = 59.89 \text{ Hz}$$

---

## F-19 Power-Up Start Enable

This parameter determines whether the motor starts automatically when the drive is powered up.

<b>Parameter Range:</b>	OFF = Motor does not start at drive power up. ON = Motor starts at drive power up.
<b>Default Setting:</b>	OFF
<b>Step Size:</b>	N/A



**ATTENTION:** Setting F-19 = ON causes output power to be applied to the motor automatically at drive power up. When this function is enabled, the user must ensure that automatic start up of the driven equipment will not cause injury to operating personnel or damage to the driven equipment. In addition, the user is responsible for providing suitable audible or visual alarms or other devices to indicate that this function is enabled and the drive may start at any moment

When F-19 = ON, output power is applied to the motor at drive power up if the following conditions are met:

- The drive power-up diagnostics must be passed (SELF will be displayed at power up).
- No faults can be active.
- The terminal strip function loss input must be closed.
- The front-panel keypad STOP/RESET key must not be pressed.

If the drive is under local control, it will effectively simulate a start signal to start the drive.

If the drive is under remote control, the drive will start only if the terminal strip START input is asserted.

---

## F-20 Password Lockout Enable

This parameter enables or disables parameter password protection.

<b>Parameter Range:</b>	OFF = Password lockout disabled (parameters can be modified) ON = Password lockout enabled (parameters cannot be modified)
<b>Default Setting:</b>	OFF
<b>Step Size:</b>	N/A



**ATTENTION:** It is the user's responsibility to determine how to distribute the password. Reliance Electric is not responsible for unauthorized access violations within the user's organization.

When F-20 = ON, parameter values can be displayed but cannot be modified (except F-20). Entering the factory-set password number (257) toggles the state of the lockout. Refer to section 8.2, Ensuring Program Security for this procedure.

**Important:** There is no visual indication of the status of this feature. You must access F-20 to verify its current value (ON or OFF).

---

## F-21 Avoidance Frequency

This parameter specifies the midpoint of the avoidance band selected in F-22.

<b>Parameter Range:</b>	Minimum speed to maximum speed (Hz)
<b>Default Setting:</b>	5.0
<b>Step Size:</b>	0.10 Hz

The avoidance band can help alleviate problems with vibrations/harmonics at a specific operating frequency of the driven motor or machinery. Refer to the F-22 parameter description for more information.

---

## F-22 Avoidance Bandwidth

This parameter sets the avoidance bandwidth. Any frequency that falls within the avoidance band results in a generated frequency below the bandwidth

<b>Parameter Range:</b>	0 to 30 Hz (0 = avoidance frequency disabled)
<b>Default Setting:</b>	0
<b>Step Size:</b>	0.10 Hz

This parameter is used with parameter F-21 (Avoidance Frequency). The drive can accelerate and decelerate through the avoidance band. However, it cannot operate at a steady state at any of the avoidance band frequencies. Setting F-22 to 0 disables the avoidance frequency.

## F-22 Avoidance Bandwidth (continued)

<b>Example</b>	
Assume:	
Minimum Speed (F-03) = 3 Hz	
Maximum Speed (F-04) = 60.0 Hz	
Avoidance Frequency (F-21) = 32.2 Hz	
Avoidance Bandwidth (F-22) = 4 Hz	
Avoidance Band = 30.2 to 34.2 Hz	
Requested Output Frequency	Output Frequency After Avoidance Band Correction
25.0 Hz	25.0 Hz
30.0 Hz	30.0 Hz
31.0 Hz	30.2 Hz
32.0 Hz	30.2 Hz
34.0 Hz	30.2 Hz
34.2 Hz	30.2 Hz
34.3 Hz	34.3 Hz
35.0 Hz	35.0 Hz

## F-23, F-24, and F-25 Multi-Speed Presets 1, 2, and 3

These parameters allow the setting of up to three different preset speeds.

<b>Parameter Range:</b>	Minimum speed to maximum speed
<b>Default Setting:</b>	20 Hz
<b>Step Size:</b>	0.10 Hz

Setting F-00 = 3 (multi-speed configuration) reconfigures the terminal strip control inputs as follows:

Terminal 6 = START/STOP/IET RESET (open = STOP; closed = IET RESET/START)  
 Terminal 7 = MSPD 1  
 Terminal 8 = MSPD 0

Refer to section 5.2.

Terminals 7 and 8 are used to select the reference source as shown in table 8.1.

Table 8.1 – Multi-Speed Presets Digital Inputs

MSPD 1	MSPD 0	Reference Source
Open (0)	Open (0)	Terminal strip analog input (variable speed)
Open (0)	Closed (1)	Multi-Speed #1 (F-23)
Closed (1)	Open (0)	Multi-Speed #2 (F-24)
Closed (1)	Closed (1)	Multi-Speed #3 (F-25)

## F-26 Auto-Restart Number of Attempts

This parameter selects the number of times the drive will attempt to restart after certain faults have shut down the drive.

**Parameter Range:** 0 to 10  
**Default Setting:** 0  
**Step Size:** N/A



**ATTENTION:** If parameter F-26  $\neq$  0, the drive will attempt to restart automatically after auto-restartable drive faults (see table 8.2) have shut down the drive. When this feature is enabled, the user must ensure that automatic restart of the driven equipment will not cause injury to operating personnel or damage to the driven equipment

If F-26  $\neq$  0, the drive logs and resets certain faults (called auto-restartable faults and listed in table 8.2) it detects while running. The drive then waits the amount of time specified in F-27 (Auto-Restart Retry Wait Time) and restarts the drive automatically.

While the drive counts down the auto-restart time period, the display flashes the countdown period (in seconds) in the following format:

“Ar30 .. Ar29 .. Ar28 ..... Ar01 .. Ar00”

This shows the amount of time remaining before the auto-restart takes effect.

Once the drive restarts, it must run for 5 minutes in order to reset the number of fault reset attempts to the value in F-26.

If the fault occurs again, the drive decrements the number of auto-restart attempts, counts down the auto-restart time again, and continues the auto-restart process. If the drive faults on all of these attempts, it remains in the faulted state and displays the fault code for the fault it is trying to clear.

If the Stop/Reset input is asserted during the countdown, the auto-restart procedure is cancelled and the fault is latched.

If a fault occurs that is auto-restartable and other faults are active that are not auto-restartable, the auto-restart function will be disabled until all faults are cleared.

When F-26  $\neq$  0, the drive logs the first occurrence of a fault in the fault log. Any subsequent occurrence of that fault while attempting to restart the drive will not be logged.

Table 8.2 lists the auto-restartable faults.

Table 8.2 – Auto-Restartable Faults

Fault Code	Description
HU	High bus voltage
LU	Low bus voltage
OC	Overcurrent
OH	Thermostat/drive overload
OL	Electronic thermal overload



---

## F-27 Auto-Restart Retry Wait Time

This parameter specifies the amount of time the drive will wait between auto-restart attempts.

<b>Parameter Range:</b>	1 to 30 seconds
<b>Default Setting:</b>	1
<b>Step Size:</b>	1.0 second

This parameter is used with parameter F-26 (Auto-Restart Number of Attempts). Refer to the F-26 parameter description for information regarding this feature.

---

## F-28 Drive Voltage Selection

This parameter displays the drive's voltage rating.

<b>Parameter Range:</b>	N/A
<b>Default Setting:</b>	N/A
<b>Step Size:</b>	N/A



**ATTENTION:** This parameter is set at the factory and must not be changed by the user.

---

## F-29 Analog Output Select

This parameter selects which monitor mode value is directed to the analog output (regardless of which monitor mode value is displayed).

<b>Parameter Range:</b>	SPd = Current RPM/speed output LOAd = Current percent load output UOL = Current calculated output voltage rEF = Current percent of selected reference
<b>Default Setting:</b>	SPd
<b>Step Size:</b>	N/A

Refer to table A.5 in Appendix A for more detail about the analog output.

---

## F-49 Version Information

This parameter displays the software version.

<b>Parameter Range:</b>	N/A
<b>Default Setting:</b>	N/A
<b>Step Size:</b>	N/A



## Troubleshooting Reference



**ATTENTION:** Only qualified electrical personnel familiar with the construction and operation of this equipment and the hazards involved should install, adjust, operate, and/or service this equipment. Read and understand this manual in its entirety before proceeding.

The SP500 drive is monitored by internal diagnostics. If a fault occurs, the drive displays a two-digit fault code to identify the problem. A fault causes the drive to coast to rest if it is running or prevents the drive from starting if it is stopped. The fault code is also entered into the error log.

This chapter defines the fault codes and suggests actions to correct problems. It also describes how to access and clear the error log.

Refer also to the F-26 (Auto-Restart Number of Attempts) parameter description in chapter 8. This describes the drive's reaction to drive faults if the auto-restart feature is enabled (F-26  $\neq$  0).

**Important:** Before servicing the drive, verify that the DC bus capacitors have discharged as described in section 9.1. Use an isolated multimeter to measure the DC bus voltage and to make resistance checks. Note that dedicated troubleshooting test points are not provided.

### 9.1 Verifying DC Bus Voltage



**ATTENTION:** DC bus capacitors retain hazardous voltages after input power has been disconnected. After disconnecting input power, wait five minutes for the DC bus capacitors to discharge and then check the voltage with a voltmeter to ensure the DC bus capacitors are discharged before touching any internal components.

The SP500 drive's DC bus capacitors retain hazardous voltages after input power has been disconnected. Perform the following steps before touching any internal components:

- Step 1. Turn off, lock out, and tag input power to the drive. Wait five minutes.
- Step 2. Remove the drive's cover.
- Step 3. Verify that there is no voltage at the drive's input power terminals.
- Step 4. Measure the DC bus voltage at the DC bus power terminals with a multimeter while standing on a non-conductive surface and wearing insulated gloves (600V). See figures 9.1 to 9.3. Once the drive has been serviced, reattach the drive's cover and reapply input power.

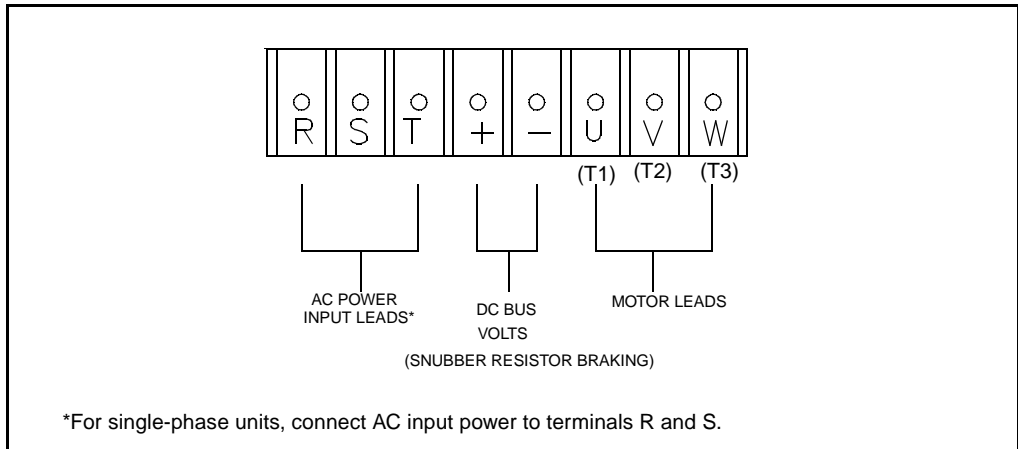

Figure 9.1 – DC Bus Terminals on Model 1SU1xxxx and 1SU2xxxx Drives

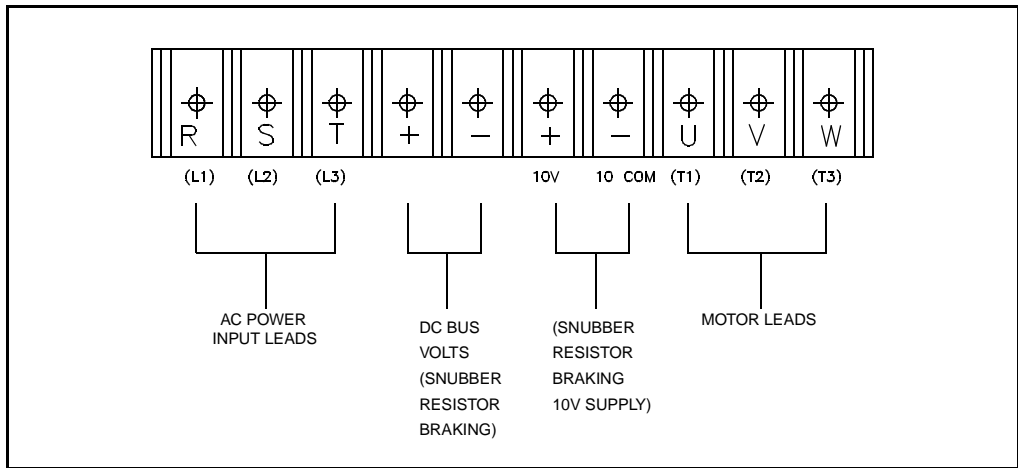

Figure 9.2 – DC Bus Terminals on Model 1SU4xxxx and 1SU5xxxx Drives (except 1SU4x015, 1SU4x020)

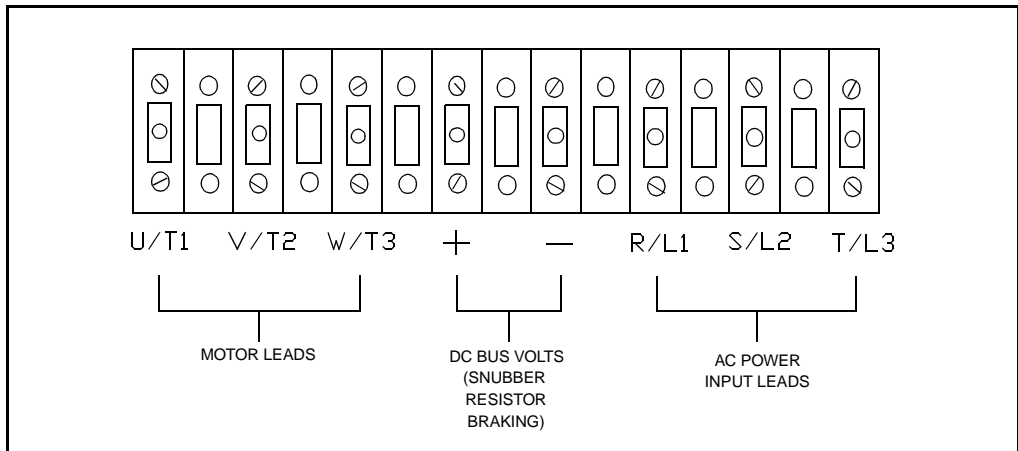

Figure 9.3 – DC Bus Terminals on Model 1SU4x015 and 1SU4x020 Drives

## 9.2 Troubleshooting the Drive Using Fault Codes

Table 9.1 defines the fault codes for user-correctable faults, lists possible causes, and suggests actions to take to correct the problem. **All other faults require replacement of the drive.**

If a fault occurs, do the following:

- Step 1. Try to clear the fault first by pressing the STOP/RESET key or asserting the IET reset input (remote operation). If the fault reoccurs, continue with step 2.
- Step 2. Refer to table 9.1 to identify the fault code and the possible causes.
- Step 3. Perform the suggested corrective action(s).
- Step 4. Clear the fault by pressing the STOP/RESET key or asserting the IET reset input.

Table 9.1 – Drive Faults and Corrective Actions

<p><b>FL = FUNCTION LOSS</b></p> <p>The function loss input signal has been asserted (terminals 10 and 11).</p>	
Possible Cause	Corrective Action
The external equipment connection to the function loss terminals has failed or is giving repeated stop requests.	<p>Check the external equipment wired to the remote function loss terminals (10 and 11). Refer to chapter 5.</p> <p>Check the function loss input connections.</p>
<p><b>HU = HIGH BUS VOLTAGE</b></p> <p>The DC bus is charged above the electronic trip threshold. Note that the fault will not clear until the bus falls below the high bus level.</p>	
Possible Cause	Corrective Action
<p>The deceleration rate setting in F-02 is too fast.</p> <p>The drive was started into a forward-running load that has a high inertia.</p> <p>High input line.</p>	<p>Decrease the deceleration rate in F-02. Refer to chapter 8 for the F-02 parameter description. Install the optional snubber resistor braking kit.</p> <p>Install the optional snubber resistor braking kit.</p> <p>Verify that the AC input is within specification. Install an isolation transformer if required.</p>

## **LU = LOW BUS VOLTAGE**

The DC bus voltage has fallen below the electronic trip low threshold level. Note that the fault will not clear until the input line voltage is within the proper range. This may take a few seconds.

**Important:** If a line dip or momentary power loss occurs and the DC bus is able to rise back to the proper level within 500 ms, the drive will automatically restart (if the drive was running when the fault occurred).

<b>Possible Cause</b>	<b>Corrective Action</b>
Loss of input power.	Check incoming power.
Low line voltage.	Check incoming power. Install an isolation transformer if required.

## **DC = OVERCURRENT**

The drive's 200% current rating has been exceeded.

<b>Possible Cause</b>	<b>Corrective Action</b>
Short in the drive outputs.	Verify that the drive's input and output wiring are properly connected. Refer to chapter 5.
Ground fault condition.	Verify that the drive's input and output wiring are properly connected. Refer to chapter 5.
Instantaneous overcurrent resulting in 200% rated drive current.	Verify that the output wiring to the motor is not connected to ground or any other voltage source. Refer to chapter 5.
	Increase the acceleration time in F-01 or the deceleration time in F-02. Refer to chapter 8 for parameter descriptions.
	Adjust the current limit level in F-05 if it is too low or too high relative to the load. Make the adjustments in 5% increments.

## **OH = THERMOSTAT / DRIVE OVERLOAD**

The internal thermostat detected excessive temperatures in the drive. Note that the fault will not clear until the internal drive temperature is back within range. This may take a few seconds.

<b>Possible Cause</b>	<b>Corrective Action</b>
The drive's operating specifications have been exceeded.	Check the application and change the carrier frequency in F-10. Refer to chapter 8 for the parameter description.
The ambient operating temperature of the drive has been exceeded. See Appendix A.	Check the temperature at the installation site. Move the drive to a cooler location.

<b>OL = ELECTRONIC THERMAL OVERLOAD</b>	
The electronic thermal overload trip level has been exceeded. This fault protects the drive motor from overheating due to excessive current within a specified period. Note that the fault will not clear until the input line voltage is within the proper range. This may take a few seconds.	
<b>Possible Cause</b>	<b>Corrective Action</b>
The current limit setting in F-05 is incorrect.	If the current limit level is too low relative to the load, increase the current level in F-05. Refer to chapter 8 for the parameter description.
The electronic thermal overload setting in F-14 does not match the motor and drive combination.	Verify the value of F-14. Refer to chapter 8 for the parameter description.
<b>r1,r2 = POWER SUPPLY OUT OF RANGE</b>	
The power supply is out of range.	
<b>Possible Cause</b>	<b>Corrective Action</b>
Possible regulator failure.	Contact Reliance Electric for assistance if the fault reoccurs after pressing the STOP/RESET key (or asserting the IET reset input) or cycling power.
<b>SELU = INVALID DRIVE VOLTAGES</b>	
The value in F-28 is incorrect for the drive.	
<b>Possible Cause</b>	<b>Corrective Action</b>
An invalid drive voltage was selected in F-28.	Select the voltage to match the input line voltage.

### 9.3 Accessing and Clearing the Error Log

If a fault occurs, the drive displays a fault code and logs the fault code into the error log. If more than one fault occurs, the first fault flashes on the display and the subsequent faults (up to two) are logged in the error log. After three faults, no subsequent faults are logged.

The faults in the error log are numbered sequentially. For example, if an overcurrent fault occurred first followed by a thermal overload fault, the error log would read 1-OC, 2-OL.

The last fault to occur appears first when the error log is accessed. For example, if the last fault to occur was a low bus fault, and the error log contained three entries, the error log would display 3-LU when the error log is accessed.

Use the following procedure to access the error log:

---

Step 1. Enter program mode by pressing the MODE/ENTER key until the PROGRAM LED turns on.

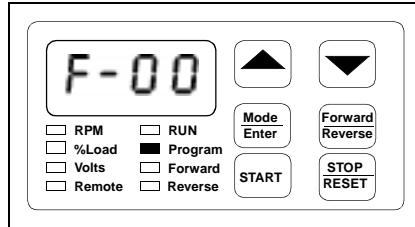

---

Step 2. Press the  key until ERR is displayed. The error log precedes parameter F-00 and follows F-49.

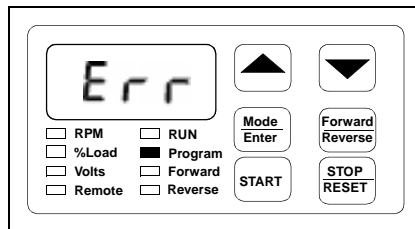

(Sample Display)

---

Step 3. Press the MODE/ENTER key to access the error log.

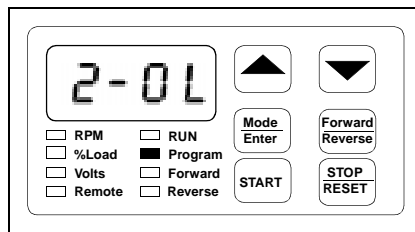

(Sample Display)

---

Step 4. Press the  key to move through the error codes.

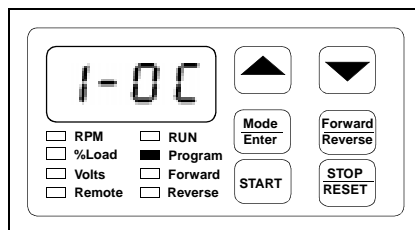

(Sample Display)



---

Step 5. Press the STOP/RESET key to clear the log.

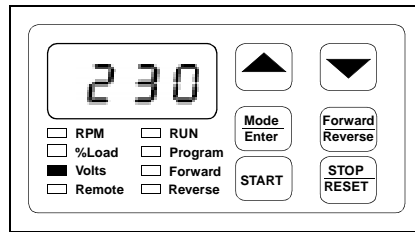

The display will return to the active monitor display.

---

## 9.4 Checking the Drive's Power Module Circuitry with the Power Off



**ATTENTION:** DC bus capacitors retain hazardous voltages after input power has been disconnected. After disconnecting input power, wait five (5) minutes for the DC bus capacitors to discharge and then check the voltage with a voltmeter to ensure the DC bus capacitors are discharged before touching any internal components.

Use the following procedure to check the drive's Power Module circuitry. Note that this test is performed with the power off.

- Step 1. Turn off and lock out input power. Wait five minutes.
- Step 2. Remove the drive's cover.
- Step 3. Verify that there is no voltage at the drive's input power terminals.
- Step 4. Check the DC bus voltage with a voltmeter as described in section 9.1 to ensure that the DC bus capacitors are discharged.
- Step 5. Disconnect the motor from the drive.
- Step 6. Check all AC line and DC bus fuses.
- Step 7. If a fuse is open, use a multimeter to check the input diodes and output IGBTs. See tables 9.2 and 9.3.
- Step 8. Reconnect the motor to the drive.
- Step 9. Reattach the drive's cover.
- Step 10. Reapply input power.

Table 9.2 – Resistance Checks for Input Diodes

Input Diode No.	Meter Connection		Component is OK if resistance (R) is:	Component is defective if:
	(+)	(-)		
1	*	R/L1	50 < R < 10 Megohm	Continuity (short circuit) or open when the meter is connected with reversed polarity.
2	*	S/L2		
3	*	T/L3		
4	R/L1	**		
5	S/L2	**		
6	T/L3	**		

\* (+) DC bus volts power terminal  
 \*\* (-) DC bus volts power terminal

Table 9.3 – Resistance Checks for IGBTs

IGBT No.	Meter Connection		Component is OK if resistance (R) is:	Component is defective if:
	(+)	(-)		
1	*	W/T3	50 < R < 10 Megohm	Continuity (short circuit) or open when the meter is connected with reversed polarity.
2	*	V/T2		
3	*	U/T1		
4	W/T3	**		
5	V/T2	**		
6	U/T1	**		

\* (+) DC bus volts power terminal  
 \*\* (-) DC bus volts power terminal

# APPENDIX A

## Technical Specifications

Table A.1 – Service Conditions

AC Line Distribution Capacity (Maximum)	100KVA, single-phase 115VAC and three-phase 230VAC, with 5,000 amps symmetrical fault current capacity for M/N 1SU1xxxx and 1SU2xxxx drives  1000KVA, three-phase 460 and 575 VAC, with 30,000amps symmetrical fault current capacity for M/N 1SU4xxxx and 1SU5xxxx drives
Control Method	All-digital, pulse-width-modulated (PWM)
Carrier Frequency	4 kHz, 6 kHz, or 8 kHz, software selectable
Displacement Power Factor	0.96
Line Frequency	50/60 Hz ( $\pm 5$ Hz)
Line Voltage Variation	-10% to +10%
Line Dip RideThrough	500 milliseconds
Linearity	0.05 (Speed reference to output frequency)
Long-term Frequency Stability	0.01%
Minimum Frequency Range	0.5 – 30 Hz
Maximum Frequency Range	30 – 240 Hz
Maximum Load	150% for 1 minute (nominal, based on drive nameplate rating)
Motor Lead Lengths	76 meters (250feet) total (See table 3.7 for more information)
Overcurrent Trip IET	200% rated drive current

Table A.2 – Dimensions

Enclosure	Height	Depth	Width	Weight
A	304.8mm (12.00")	121.9mm (4.80")	146.0mm (5.75")	2.7kg (6 lb)
B	301.7mm (11.88")	160.1mm (6.30")	222.3mm (8.75")	5.4kg (12 lb)
C	357.8mm (14.10")	158.2 mm (6.20")	278.1 mm (10.9")	8.1kg (18 lb)
D	465.2mm (18.31")	198.9mm (7.83")	286.5mm (11.28")	15.3kg (34 lb)

Table A.3 – Environmental Conditions

Operating Temperature	0° to +40°C (32° to 104°F) – enclosed drives 0° to +55°C (32° to 131°F) – open chassis (cover removed)
Storage Temperature	-40° to +65°C (-40° to +149°F)
Humidity	5 to 95% (non-condensing)
Altitude	Do not install the drive above 1000 meters (3300 feet) without derating output power. For every 91.4 meters (300 feet) above 1000 meters (3300 feet) up to 3033 meters (10,000 feet), derate the output current by 1%. Above 3033 meters (10,000 feet), contact your local Reliance Electric sales office for assistance.

Table A.4 – Drive Inputs

Analog Speed Reference	0 to 10 VDC or 0 to 20 mA
Start	Edge-sensitive signal that must see an open-to-closed contact transition. This transition may be a momentary or fixed closure.
Stop	An open contact that must be closed when the drive is running. The drive will remain off as long as the contact is open.
IET Reset	Edge-sensitive signal that must see an open-to-closed contact transition. This transition may be a momentary or fixed closure.
Forward/Reverse	An open contact to assert the forward direction and a closed contact to assert the reverse direction.
Function Loss	An open contact that must be closed when the drive is running. When the contact is open, the drive turns off. The drive will remain off as long as the contact is open.

Table A.5 – Drive Outputs

Analog Output (0-10 VDC scaled signal)	<p>The scaled signal is selected through parameter F-29 and can be one of the following:</p> <ul style="list-style-type: none"> <li>• Output Voltage: 0 to 115 VAC (M/N 1SU1xxxx drives) 0 to 253 VAC (M/N 1SU2xxxx drives) 0 to 506 VAC (M/N 1SU4xxxx drives) 0 to 632 VAC (M/N 1SU5xxxx drives)</li> <li>• % Load (Amps): 0 to 200% (Percentage of output amps based on the drive nameplate.)</li> <li>• RPM/Engineering Unit: Minimum to maximum RPM or minimum to maximum of any engineering unit (See parameter F-08)</li> <li>• % Selected Speed Reference: 0 to 100% (Percentage of the selected reference signal range.)</li> </ul>
Snubber Resistor Braking	Snubber resistor control signal used by an optional snubber resistor.
Output Status Relay	115 VAC/24 VDC, 0.5 Amp, relay output (One Form A and one Form B contact wired with a single common.)

# APPENDIX B

## Record of User Settings

Parameter No.	Parameter Name	Range	Step Size	Default Setting	Setting	Date
F-00	Control Source Select	0, 1, 2, 3	N/A	0		
F-01	Accel Time (seconds)	0.5 - 90.0	0.10	5.0		
F-02	Decel Time (seconds)	0.5 - 90.0	0.10	5.0		
F-03	Minimum Speed (Hz)	0.5 - 30.0	0.10/0.25	5.0		
F-04	Maximum Speed (Hz)	30.0 - 240.0	0.10/0.25	60.0		
F-05	Current Limit (%)	10 - 150	1.0	150		
F-06	Manual Torque Boost (%)	2 - 10	1.0	2		
F-07	V/Hz Base Speed (Hz)	3 - 240	1.0	60		
F-08	RPM at Base Speed	10 - 9999	1.0	1750		
F-09	Configurable Output Relay Select	0, 1, 2	N/A	0		
F-10	Carrier Frequency (kHz)	4, 6, 8	N/A	4		
F-11	Remote Reference Gain (%)	60 - 100	0.10	100		
F-12	Remote Reference Offset (%)	0 - 40	0.10	0		
F-13	Percent Selected Speed Reference Display Enable	ON, OFF	N/A	OFF		
F-14	Electronic Thermal Overload (%)	20 - 100	1.0	100		
F-15	Electronic Thermal Overload Enable	ON, OFF	N/A	ON		
F-16	Coast Stop Enable	ON, OFF	N/A	ON		
F-17	Reverse Disable	ON, OFF	N/A	OFF		
F-18	RPM Setpoint Enable	ON, OFF	N/A	OFF		
F-19	Power-Up Start Enable	ON, OFF	N/A	OFF		
F-20	Password Lockout Enable	ON, OFF	N/A	OFF		
F-21	Avoidance Frequency (Hz)	Min speed - Max speed	0.10	5		
F-22	Avoidance Bandwidth (Hz)	0.0 - 30.0	0.10	0		
F-23	Multi-Speed Preset 1 (Hz)	Min speed - Max speed	0.10	20		
F-24	Multi-Speed Preset 2 (Hz)	Min speed - Max speed	0.10	20		
F-25	Multi-Speed Preset 3 (Hz)	Min speed - Max speed	0.10	20		

Parameter No.	Parameter Name	Range	Step Size	Default Setting	Setting	Date
F-26	Auto-Restart Number of Attempts	0 - 10 0 = disabled	N/A	0		
F-27	Auto-Restart Retry Wait Time (seconds)	1 - 30	1.0	1		
F-28	Drive Voltage Selection	This parameter is set at the factory. Do not change the setting.				
F-29	Analog Output Select	SPd LOAd UOL rEF	N/A	SPd		
F-49	Version Information	x.xx	N/A	Read Only		

## Alphabetical Listing of Parameters

Acceleration Time .....	F-01
Analog Output Select.....	F-29
Auto-Restart Number of Attempts.....	F-26
Auto-Restart Retry Wait Time.....	F-27
Avoidance Bandwidth .....	F-22
Avoidance Frequency .....	F-21
Carrier Frequency.....	F-10
Coast Stop Enable.....	F-16
Configurable Output Relay Select.....	F-09
Control Source Select.....	F-00
Current Limit .....	F-05
Deceleration Rate .....	F-02
Drive Voltage Selection.....	F-28
Electronic Thermal Overload .....	F-14
Electronic Thermal Overload Enable .....	F-15
Manual Torque Boost.....	F-06
Maximum Speed.....	F-04
Minimum Speed.....	F-03
Multi-Speed Preset 1 .....	F-23
Multi-Speed Preset 2 .....	F-24
Multi-Speed Preset 3 .....	F-25
Password Lockout Enable.....	F-20
Percent Selected Speed Reference Display Enable.....	F-13
Power-Up Start Enable .....	F-19

Remote Reference Gain.....	F-11
Remote Reference Offset.....	F-12
Reverse Disable .....	F-17
RPM at Base Speed.....	F-08
RPM Setpoint Enable.....	F-18
V/Hz (Base Speed) .....	F-07
Version Information .....	F-49



## Compliance with Machinery Safety Standard EN-60204-1:1992

The SP500 AC Speed Controller for Electric Motors complies with the following sections of Machinery Safety Standard EN-60204-1:1992.

EN-60204-1 Section	Title
6 6.2.1 6.2.3 6.3.1 6.4	Protection against electrical shock - Protection by enclosure - Protection against residual voltages - Protection by automatic disconnect of supply - Protection by the use of PELV (Protective Extra Low Voltage)
7 7.2 7.2.3 7.2.6 7.5	Protection of equipment - Overcurrent protection - Control circuits - Transformers - Protection against supply interruption or voltage reduction and subsequent restoration
8 8.2.1 8.2.2 8.2.3 8.2.7 8.3 8.4 8.5 8.6	Equipotential bonding - General (the PE terminal) - Protective conductors (connection points) - Continuity of the protective bonding circuit - Protective conductor connecting points - Bonding of the protective bonding circuit for operational purposes - Insulation failures - Bonding to a common reference potential - Electrical interferences
9 9.1.1 9.1.3 9.1.4 9.2 9.2.1 9.2.2 9.2.3 9.2.5 9.2.5.3 9.2.5.6 9.2.6	Control circuit and control functions - Control circuit supply - Protection - Connection of control devices - Control functions - Start function - Stop function - Operating modes - Operation - Stop - Hold-to-run controls - Combined start and stop controls

EN-60204-1 Section	Title
9.3 9.3.5 9.4 9.4.2.1 9.4.3 9.4.3.1 9.4.3.2	<ul style="list-style-type: none"> <li>- Protective interlocks</li> <li>- Reverse current braking</li> <li>- Control functions in case of failure</li> <li>- Use of proven circuit techniques and components</li> <li>- Provisions for redundancy</li> <li>- Earth faults</li> <li>- Voltage interruption</li> </ul>
10 10.8	<p>Operator interface and machine mounted control devices</p> <ul style="list-style-type: none"> <li>- Display</li> </ul>
11 11.2 11.2.1 11.2.2 11.3 11.3.1 11.5	<p>Control interfaces</p> <ul style="list-style-type: none"> <li>- Digital input/output interfaces</li> <li>- Inputs</li> <li>- Outputs</li> <li>- Drive interfaces with analog inputs</li> <li>- Separation between control and electric drives</li> <li>- Communications</li> </ul>
12 12.2.2 12.2.3 12.3 12.3.1 12.3.2 12.3.3 12.3.4 12.3.5	<p>Electronic equipment</p> <ul style="list-style-type: none"> <li>- Electronic control equipment</li> <li>- Equipotential bonding</li> <li>- Programmable equipment</li> <li>- Programmable controllers</li> <li>- Memory retention and protection</li> <li>- Programming equipment</li> <li>- Software verification</li> <li>- Use in safety-related functions</li> </ul>
13 13.2.3 13.4	<p>Controlgear: Location, mounting and enclosures</p> <ul style="list-style-type: none"> <li>- Heating effects</li> <li>- Enclosures, doors and openings</li> </ul>
15 15.1.1 15.1.3 15.2.2	<p>Wiring practices</p> <ul style="list-style-type: none"> <li>- General requirements</li> <li>- Conductors of different circuits</li> <li>- Identification of the protective conductor</li> </ul>
18 18.2 18.4	<p>Warning signs and item identification</p> <ul style="list-style-type: none"> <li>- Warning signs</li> <li>- Marking of control equipment</li> </ul>
19 19.1	<p>Technical documentation</p> <ul style="list-style-type: none"> <li>- General</li> </ul>

## Compliance with Electromagnetic Compatibility Standards

### E.0 Introduction

This appendix provides information on the SP500 drive's compliance with European community electromagnetic compatibility standards and covers the following:

- Requirements for standards compliance
- Guidelines on installing the AC Mains Filter
- Instructions on how the drive must be wired

The SP500 drives listed on the Declaration of Conformity (DOC) have been tested and are in compliance with the following standards when installed with the appropriate AC Mains Filter:

- EN50081-1 (1992)  
Electromagnetic compatibility - Generic emission standard  
Part 1: Residential, commercial, and light industrial
- EN50081-2 (1992)  
Electromagnetic compatibility - Generic emission standard  
Part 2: Industrial
- EN50082-1 (1992)  
Electromagnetic compatibility - Generic immunity standard  
Part 1: Residential, commercial, and light industrial
- EN50082-2 (1995)  
Electromagnetic compatibility - Generic immunity standard  
Part 2: Industrial

Note that the conformity of the SP500 drive to the above standards does not guarantee that the entire installation will be in conformance.

Contact the Rockwell AutoFax service at 216-646-7777 for copies of the Declaration of Conformity (DOC).

### E.1 Compliance Requirements

In order for the SP500 drive to conform to the standards listed in section E.0, the drive must:

- be specified by model number on the DOC.
- have a CE mark. This mark is found on the drive's certification label.
- include an AC Mains Filter. See section E.2 for information on installing the filter.

- be installed according to the instructions in this appendix.

Note that when using 15 – 20 HP SP500 drives, a special cover is required. The model number of the SP500 cover kit is M/N 2CK4120. Follow the instructions provided with the kit when replacing the cover. The instructions in this appendix assume that the drive has the correct cover on it.

## E.2 Installing the AC Mains Filter

This section describes how to identify and install the AC Mains Filters. These filters have been designed to limit the conducted electromagnetic emissions to the AC power mains from the SP500 drives.

Table E.1 identifies the SP500 drives that are in conformance with the standards listed in section E.0 and their corresponding AC Mains Filters. Verify that you have the correct AC Mains Filter for your application.

Table E.1 – AC Mains Filters

HP	SP500 Model Number	AC Mains Filter Model Number
1	1SU21001	2DF2282
1	1SU41001	2DF4283
2	1SU21002	2DF2282
2	1SU41002	2DF4283
3	1SU21003	2DF4283
3	1SU41003	2DF4283
5	1SU21005	2DF4283
5	1SU41005	2DF4283
7.5	1SU41007	2DF4284
10	1SU41010	2DF4284
15	1SU41015	2DF4285
20	1SU41020	2DF4285

Use the following guidelines to mount the SP500 drive to the AC Mains Filter and then mount the drive/filter assembly to a panel:

- Attach the SP500 drive to the AC Mains Filter. See figure E.1. No other type of mounting is permitted. The required mounting hardware is supplied with the filter.
- Attach the SP500 drive/AC Mains Filter assembly to a panel or wall. See figure E.1 and table E.2 for mounting dimensions. The panel/wall surface does not have to be conductive, although it is preferable. The user must supply the hardware for mounting the drive/filter assembly to the panel/wall.

Top View  
(Filter Only, Cover Removed)

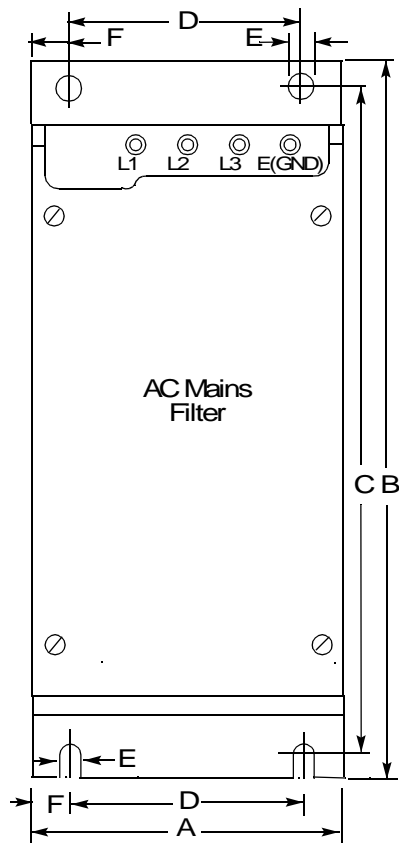
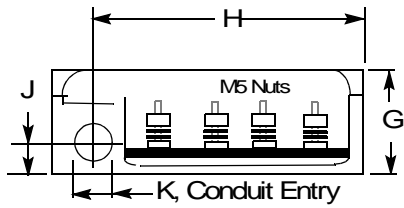

Front View  
(Filter Only)

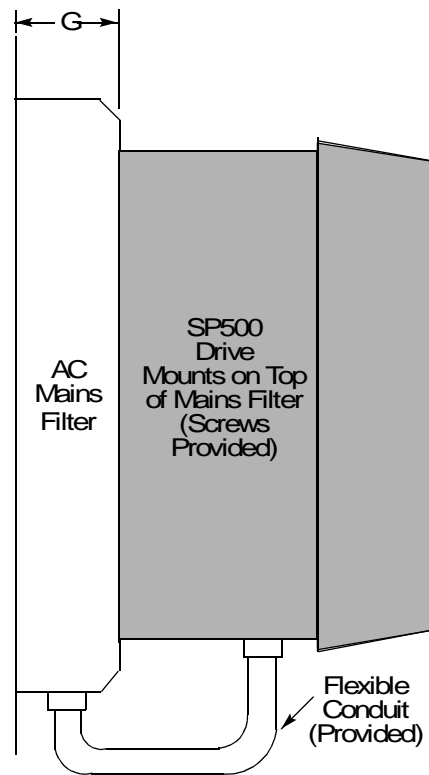

Side View  
(Filter and Drive)

See table E.2 for dimensions.

Figure E.1 – AC Mains Filter Dimensions

Table E.2 - AC Mains Filter Mounting Dimensions and Weights

Dimension	AC Mains Filter M/N 2DF2282	AC Mains Filter M/N 2DF4283	AC Mains Filter M/N 2DF4284	AC Mains Filter M/N 2DF4285
A	146 mm 5.7"	217 mm 8.5"	272 mm 10.7"	272 mm 10.7"
B	407 mm 16"	387mm 15.25"	441 mm 17.4"	575 mm 22.6"
C	382 mm 15"	362 mm 14.25"	415 mm 16.3"	550 mm 21.7"
D	104 mm 4.1"	174 mm 6.9"	230 mm 9.1"	232 mm 9.1"
E	9 mm 0.35"	9 mm 0.35"	9 mm 0.35"	9 mm 0.35"
F	21 mm 0.83"	21.5 mm 0.85"	21 mm 0.83"	20 mm 0.79"
G	63 mm 2.5"	53 mm 2.1"	53 mm 2.1"	93 mm 3.7"
H	118 mm 4.6"	180 mm 7.1"	231 mm 9.1"	235 mm 9.1"
J	25 mm 1"	18 mm 0.71"	18 mm 0.71"	43 mm 1.7"
K	22 mm 0.87"	22 mm 0.87"	22 mm 0.87"	28 mm 1.1"
Filter Weight	2.5 kg 5.5 lb	3.2 kg 7 lb	3.2 kg 7 lb	5 kg 11 lb

## E.3 Wiring Practices

This section describes how the SP500 drive must be wired to conform to the standards listed in section E.0. See figures E.2 and E.3 for typical SP500 connection diagrams.

### E.3.1 Connecting the AC Mains Filter Output to the SP500 Drive Input

The power leads that connect the output terminals of the AC Mains Filter to the drive's AC input terminals are included with the filter. The flexible conduit to be used with these power leads is also provided. See figures E.2 and E.3.

- Place the flexible conduit's hub in the drive's wire entry hole that is in-line with the filter's output wiring opening. Route the leads through the conduit. Secure both ends of the flexible conduit.
- Trim the power leads to the proper length and connect them to the drive's AC input power terminals (R,S,T). Connect the green/yellow ground lead to the drive's ground terminal.

Note that the filter's output leads are red, yellow, and blue. This color coding is stenciled on the printed circuit board at the filter's input power terminals to help identify the filter's output wiring relative to the filter's input wiring.

- When the drive is connected to single-phase AC input power, follow the color coding shown in figure E.2 and connect all three filter output leads to the drive's AC input power terminals.

- When the drive is connected to three-phase AC input power, the three output leads from the filter should be connected to the drive's AC input power terminals as shown in figure E.3.
- Connect the filter ground wire (green/yellow) to the drive ground.

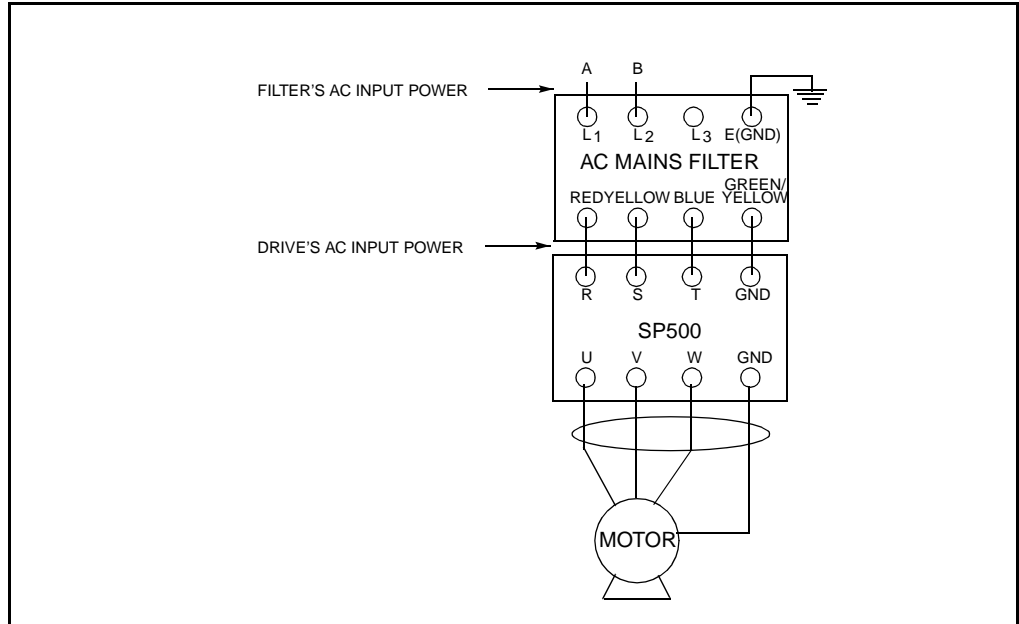

Figure E.2 - Typical SP500 Single-Phase Connections

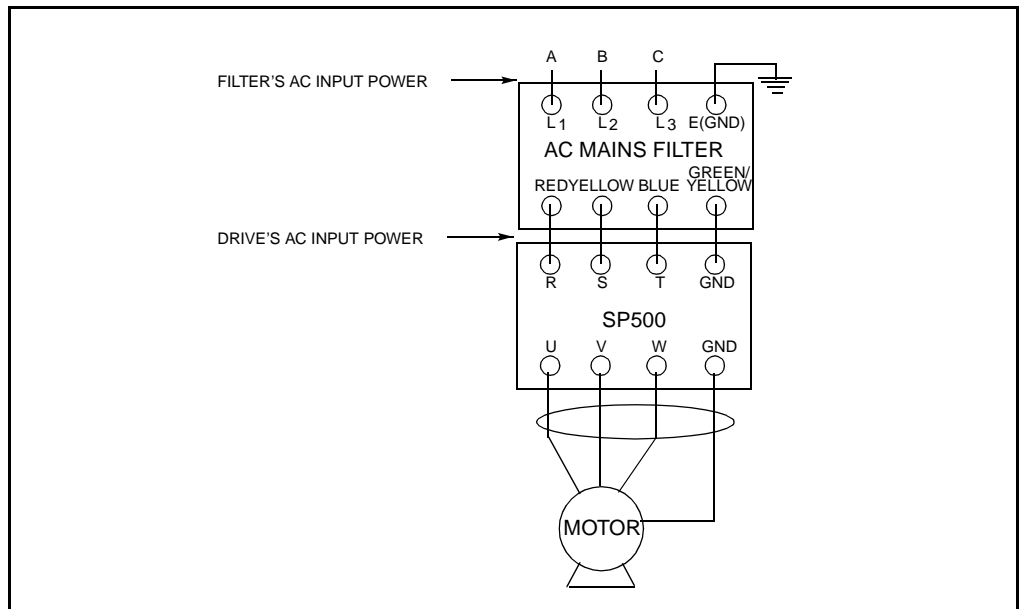

Figure E.3 - Typical SP500 Three-Phase Connections

### E.3.2 Motor Leads

The motor leads must be run in continuous, rigid, conductive conduit, continuously-screened armored cable, or equivalent. Note that the use of flexible metal conduit, open wire, or wire in trays is not acceptable. Many flexible metal conduit products have not been designed for RF containment and are not adequate to maintain compliance.

All motor leads should have the same cross-sectional area. The maximum allowable motor lead length from the drive to the motor is 76 m (250 feet).

A ground (earth) lead, equivalent in size to the motor leads, must be run with the motor leads from the motor to the drive. Terminate this lead in the drive at the ground terminal.

Proper glands must be used to terminate the motor conduit/cable. The gland must secure the cable screen to the conductive surfaces of the drive and motor. A full 360° screen termination is preferred.

Follow all instructions supplied with the motor.

### E.3.3 Connecting AC Input Power to the AC Mains Filter

Connect AC input power to the filter by first removing the filter's cover and then connecting the AC input power leads to the terminals at the top of the filter. See figure E.1. The AC input power leads should have lugs attached. The filter has a conduit opening to secure the AC input power conduit.

### E.3.4 Grounding the Drive/Filter Assembly

Connect the drive/filter assembly to earth ground at the terminal provided next to the filter's AC input power terminals. Size the ground wire per EN-60204-1, Part 5.2<sup>1</sup>, for copper conductors and EN-60204-1, Part 8.2.2.2<sup>2</sup>, for non-copper conductors. European Union standards require that the ground wire must be green/yellow according to EN-60204-1, Part 15.2.2.<sup>3</sup>

<sup>1</sup>EN-60204-1, Part 5.2: Minimum Cross-Sectional Area of the External Protective Copper Conductor

Cross-Sectional Area of Phase Conductors Supplying the Equipment (S) (mm <sup>2</sup> )	Minimum Cross-Sectional Area of the External Protective Conductor (mm <sup>2</sup> )
$S \leq 16$	S
$16 < S \leq 35$	16
$S \geq 35$	S/2

<sup>2</sup>EN-60204-1, Part 8.2.2.2: Protective Conductors

Copper conductor should be used. If a material other than copper is used, its electrical resistance per unit length should not exceed that of copper. Non-copper conductors should not be less than 16 mm<sup>2</sup> in cross-sectional area.



<sup>3</sup>EN-60204-1, Part 15.2.2: Identification of the Protective Conductor

For insulated conductors, the two-color combination of green and yellow should meet the following criteria for any given 15 mm length: one of the colors should cover at least 30% and no more than 70% of the surface, with the other color covering the remainder of the surface.

### E.3.5 Operator Control Stations

The enclosure of an operator's control station must be constructed of a conductive metal. The cover of the enclosure should be bonded to the case and not rely on the hinge for bonding. Standard industrial operator devices, e.g., pushbuttons, switches, and meters, may be used.

The wiring connecting the operator's devices to the drive must be run in continuous, rigid, conductive conduit, continuously-screened armored cable, or equivalent. Note that the use of flexible metal conduit, open wire, or wire in trays is not acceptable. Many flexible metal conduit products have not been designed for RF containment and are not adequate to maintain compliance.

Proper glands must be used to terminate the operator's control station conduit/cable at the station and the drive. The gland must secure the cable screen to the conductive surfaces of the drive and station enclosure. A full 360° screen termination is preferred. Screen pigtails are not permitted.

### E.3.6 I/O Signals

Control (I/O) and signal wiring must be run in continuous, rigid, conductive conduit or continuously-screened cable as shown in figure E.4. Note that the use of flexible metal conduit, open wire, or wire in trays is not acceptable. Many flexible metal products have not been designed for RF containment and are not adequate to maintain compliance.

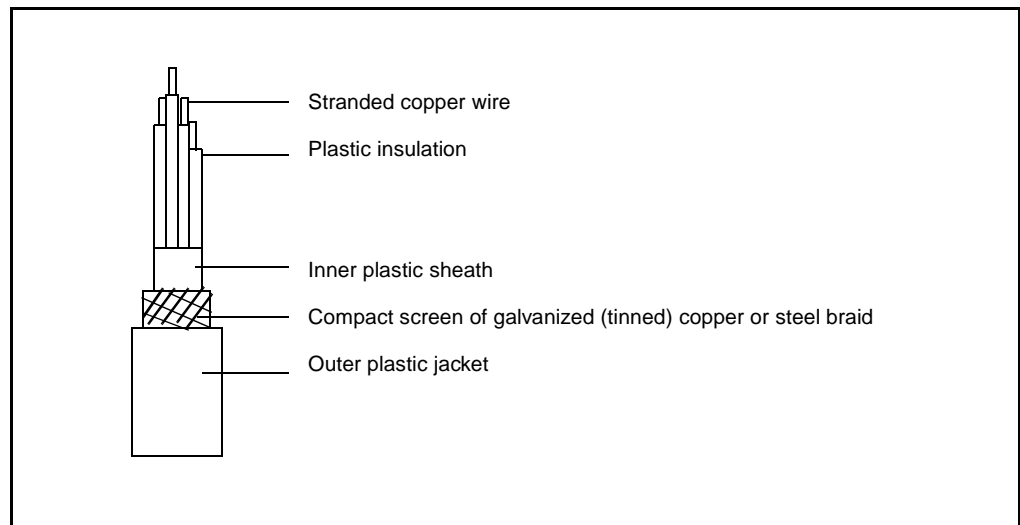

Figure E.4 - I/O Signal Cable



# APPENDIX F

## Replacement Parts

The following tables list the replacement parts available from Reliance Electric. Replacement parts are not available for 1 and 2 HP drives (M/N 1SU1xxxx and 1SU2xxxx). For M/N 1SU24002, use the replacement parts listed for the 3 HP drive.

Table F.1 – Replacement Parts List for Model 1SU2xxxx Drives

Description	Part Number	Quantity per Horsepower	
		3 HP	5 HP
Fan Assembly	615161-S	2	2
NEMA 4X Cover/Gasket	805522-1R	1	1
NEMA 1 Cover	805508-2R	1	1
Membrane Switch Keypad/Bracket	709511-1R	1	1
Regulator PCB	56952-300	1	1
Capacitor PCB	56931-050	1	1
Fan Assembly (Internal)	615159-1R	1	1

Table F.2 – Replacement Parts List for Model 1SU4xxxx Drives

Description	Part Number	Quantity per Horsepower							
		1 HP	2 HP	3 HP	5 HP	7.5 HP	10 HP	15 HP	20 HP
Fan Assembly	615161-S	–	–	1	1	2	2	2	2
NEMA 4X Cover/Gasket	805512-1R	1	1	1	1	–	–	–	–
	805522-1R	–	–	–	–	1	1	–	–
NEMA 1 Cover	805504-7R	1	1	1	1	–	–	–	–
	805508-9R	–	–	–	–	1	1	–	–
	805522-20R	–	–	–	–	–	–	1	1
NEMA 12 Cover	805512-20R	–	–	–	–	–	–	1	1
Membrane Switch Keypad/Bracket	709507-1R	1	1	1	1	–	–	–	–
	709511-1R	–	–	–	–	1	1	–	–
	709516-1R	–	–	–	–	–	–	1	1
Regulator PCB	56953-3xx	1	1	1	1	–	–	–	–
	56954-3xx	–	–	–	–	1	1	1	1
Capacitor PCB	56928-030	–	–	1	–	–	–	–	–
	56928-050	–	–	–	1	–	–	–	–
	56919-070	–	–	–	–	1	–	1	–
	56919-100	–	–	–	–	–	1	–	1
	56961	–	–	–	–	–	–	1	–
56962	–	–	–	–	–	–	–	1	
Fan Assembly (Internal)	615159-1R	1	1	1	1	1	1	1	1
Power Supply (Signal) PCB	56957	–	–	–	–	–	–	1	1
Power PCB	56963	–	–	–	–	–	–	1	1
Gate Drive PCB	56960	–	–	–	–	–	–	1	1
IGBT Module	602909-813W	–	–	–	–	–	–	3	3
Diode Bridge	701819-112BA	–	–	–	–	–	–	1	–
	701819-111BA	–	–	–	–	–	–	–	1

Table F.3 – Replacement Parts List for Model 1SU5xxxx Drives

Description	Part Number	Quantity per Horsepower					
		1 HP	2 HP	3 HP	5 HP	7.5 HP	10 HP
Fan Assembly	615161-S	–	–	1	1	2	2
NEMA 4X Cover/Gasket	805512-1R	1	1	1	1	–	–
	805522-1R	–	–	–	–	1	1
NEMA 1 Cover	805504-7R	1	1	1	1	–	–
	805508-9R	–	–	–	–	1	1
Membrane Switch Keypad/Bracket	709507-1R	1	1	1	1	–	–
	709511-1R	–	–	–	–	1	1
Regulator PCB	56953-3xx	1	1	1	1	–	–
	56954-3xx	–	–	–	–	1	1
Capacitor PCB	56922-055	–	–	1	1	–	–
	56939-105	–	–	–	–	1	1
Fan Assembly (Internal)	615159-1R	–	–	–	1	1	1

**accelerating torque** - an increase in torque (force) generated by a motor in order to achieve running speed.

**base speed** - the manufacturer's nameplate rating at which point the motor will develop rated horsepower at rated load and voltage.

**base frequency** - the motor nameplate frequency rating.

**carrier frequency** - the switching frequency at which an IGBT inverter bridge converts a DC voltage into a pulse-width modulated (PWM) voltage.

**constant torque** - a torque (force) characteristic independent of motor speed.

**current feedback** - a current signal used by the regulator to control the operating current of the drive.

**decelerating torque** - the torque (force) generated by the decrease in motor and load kinetic energy which the motor and load requires to reach its final (slower) speed condition.

**drive** - an electronic device that can control the speed, torque horsepower, and direction of an AC or DC motor.

**dynamic braking** - a braking technique in which the kinetic energy is converted into electrical energy and dissipated as heat energy via a resistor or other means.

**frequency setpoint** - the frequency value stored in memory (either by local or remote means) within a given frequency range of the drive's output voltage. This sets the speed of the motor.

**Hz** - the abbreviation for hertz. The number of cycles per second.

**IET** - the abbreviation for instantaneous electronic trip. A fault condition that occurs while the drive is running resulting in a motor coast-to-rest stop. The drive senses a condition that could result in equipment damage and turns itself off.

**input power factor** - the ratio of the input inverter AC effective power to the input AC apparent power.

**inverter** - a static power converter that changes DC power to AC power.

**line dip** - a short duration, low input voltage condition.

**load torque** - the motor torque required to keep the load rotating at nearly constant speed.

**NEMA** - the abbreviation of the National Electrical Manufacturer's Association.

**NEMA 1** - the Type 1 enclosure defined in NEMA standards that provides protection against dust, light indirect splashing, and accidental human contact with the electrical circuit.

**NEMA 4x** - the Type 4x enclosure defined in NEMA standards that provides a degree of protection from falling rain, splashing water, hose-directed water, and corrosion. The Type 4x enclosure described here is for indoor use only.

**NEMA 12** - the Type 12 enclosure defined in NEMA standards intended for use in applications where it is desirable to exclude such materials as cooling oil, seepage, dust, lint, fibers, and filings.

**overcurrent** - a current greater than a specified maximum current value.

**overload capacity** - the ability of the drive to withstand currents beyond the system's continuous rating. It is normally specified as a percentage of full load current for a specified time period.

**overtemperature** - a temperature greater than the specified (rated) temperature limit.

**power factor** - a measurement of the time phase difference between the voltage and current in an AC circuit. Power factor is the ratio of Real Power (kW) to total KVA or the ratio of actual power (W) to apparent power (volt-amperes).

**pulse-width modulation (PWM)** - a method whereby a DC voltage is converted to produce an AC voltage whose magnitude and frequency can be varied.

**rated input voltage** - the specified AC line voltage connected to the drive.

**rated output current** - the total maximum current delivered from a drive or to a motor under full load conditions.

**rated output voltage** - the drive's total maximum output voltage while delivering rated current under full load conditions.

**rated output frequency** - the fundamental output wave frequency.

**rectifier** - a static power converter that changes AC power to DC power.

**speed range** - the speed minimum and maximum at which a motor must operate under constant or variable torque load conditions.

**stall** - a motor state in which the motor remains motionless although the motor is generating torque.

**surge suppressor** - circuit protection that suppresses the peak value of any unusual input voltage to the drive. It is sometimes used to lighten the leading edge of voltage.

**torque** - a turning force applied to a shaft, tending to cause rotation.

**torque compensation** - the increase of the volts/frequency ratio of the drive in the low frequency area to compensate for the reduced torque of the motor at low speeds. Reduced torque at low speeds is due to the resistance of the motor stator windings.

**voltage feedback** - a voltage signal which the regulator uses to control the operation of the drive.

**volts per hertz (V/Hz)** - the ratio of output voltage (in volts) to output frequency (in hertz) in the output frequency range of the drive to achieve constant torque in the motor.

## A

Acceleration Time (F-01), 8-5  
 AC input  
   diodes, checking, 9-7 to 9-8  
   line branch circuit fuses, 3-8, 4-6, 5-2  
   ratings, 2-7 to 2-8  
   wire sizes, 3-4 to 3-5  
   wiring, 3-4 to 3-5, 3-8, 4-1 to 4-6, 5-1 to 5-2  
 AC line distribution capacity, A-1  
 AC mains filter, E-1 to E-6  
 AC output wiring, 3-4 to 3-7, 4-1 to 4-5, 4-7 to 4-9,  
   5-2, 5-10  
 Air flow, 3-1, 3-4  
 Altitude requirements, 3-1, A-1  
 Analog input jumper (J6), 4-7 to 4-8  
 Analog Output Select (F-29), 8-17  
 Analog output wiring, 5-4  
 Analog speed reference wiring, 5-3 to 5-4  
 Area required, 3-1 to 3-4  
 Auto-Restart Number of Attempts (F-26), 8-16  
 Auto-Restart Retry Wait Time (F-27), 8-17  
 Avoidance Bandwidth (F-22), 8-14  
 Avoidance Frequency (F-21), 8-14

## B

Board  
   Capacitor, 2-10 to 2-12, F-1 to F-2  
   Power, 2-9 to 2-12, F-1  
   Regulator, 2-9 to 2-12, F-1 to F-2  
 Braking, snubber resistor, 2-13, A-2  
   wiring, 4-2 to 4-5, 5-8 to 5-9

## C

Carrier frequency, 2-7 to 2-8, A-1  
 Carrier Frequency (F-10), 8-9  
 Coast Stop Enable (F-16), 8-12  
 Conduit size, 4-2 to 4-5  
 Configurable Output Relay Select (F-09), 8-9  
 Control Source Select (F-00), 8-5  
 Control terminal strip, 2-9 to 2-12, 5-3  
 Control wiring, 5-3 to 5-9  
 Current Limit (F-05), 8-7

## D

DC bus  
   terminals, 9-2  
   verifying capacitor voltage, 9-1 to 9-2  
 Deceleration Time (F-02), 8-5 to 8-6  
 Digital input wiring  
   Forward/reverse, 5-7, A-2  
   Function loss, 5-7, A-2  
   IET reset, 5-7, A-2  
   Multi-speed Preset, 5-6 to 5-7  
   Start/stop, 5-4 to 5-5, A-2  
 Dimensions, 3-2 to 3-3, A-1  
 Display  
   description, 7-1  
   scaling, *see* RPM at Base Speed (F-08)  
 Drive faults, *see* Faults  
 Drive Voltage Selection (F-28), 8-17

## E

Electromagnetic compatibility standards  
   AC mains filter, E-1 to E-6  
   Compliance requirements, E-1 to E-2  
   Declaration of conformity, E-1  
 Electronic Thermal Overload (F-14), 8-11  
 Electronic Thermal Overload Enable (F-15),  
   8-11 to 8-12  
 Emergency stop, 3-9  
 Enclosures, NEMA, 2-7 to 2-8  
 Environmental conditions, 3-1, A-1  
 Error log, 9-5 to 9-7

## F

Fault codes, 9-3 to 9-5  
 Faults  
   drive reaction to, 9-1  
   possible causes and corrective  
   actions, 9-3 to 9-5  
   resetting, 9-3  
 Forward, digital input, 5-5 to 5-7  
 Frequency, carrier, 2-7 to 2-8, A-1  
 Function loss, digital input, 5-5 to 5-7

## G

Grounding, 2-9 to 2-12, 5-11

## H

Humidity, 3-1, A-1

## I

IET reset, digital input, 5-5, 5-7

IGBT power devices, 2-2

checking, 9-7 to 9-8

Input, AC, *see* AC input

Input, digital, *see* Digital Input Wiring

Installation

checking with power off, 6-1 to 6-2

checking with power on, 6-2 to 6-3

completing, 6-1 to 6-3

disconnects, 4-6

output contactors, 4-7

planning, 3-1 to 3-10

requirements, 3-1

transformers, 4-6 to 4-7

## J

Jumper (J6)

location of, 4-7 to 4-8

## K

Key descriptions, 7-1 to 7-2

Keypad and display operation, 7-1 to 7-7

Kits

Option, 2-13

Snubber resistor braking, 2-13

## L

Lead lengths, motor, 3-6 to 3-7, A-1

LED descriptions, 7-3

Line frequency, A-1

Line noise, avoiding, 4-6

## M

Manual Torque Boost (F-06), 8-7

Maximum Speed (F-04), 8-6

Mechanical motor overload protection, 4-7

Membrane switch/bracket assembly, 2-9 to 2-12,  
F-1 to F-2

Minimum Speed (F-03), 8-6

Model numbers, 2-6 to 2-8

Monitor mode, 7-5 to 7-6

Motor

motor lead lengths, 3-6 to 3-7, A-1

multiple motor applications, 3-10

overload protection, mechanical, 4-7

single motor applications, 3-9

Mounting dimensions, 3-2 to 3-3, A-1

Multi-Speed Presets 1, 2, 3 (F-23, F-24, F-25), 8-15

Multi-Speed presets, digital inputs, 5-6 to 5-7

## N

NEMA enclosures, 2-8

## O

Option kits, *see* Kits

Output

current, 2-7 to 2-8

power wiring, 3-4 to 3-7, 4-1 to 4-5, 4-7 to 4-8

status relay wiring, 5-10

## P

Parameters

displaying or changing values, 8-1 to 8-2

factory settings and defaults, B-1 to B-2

listed alphabetically, C-1 to C-2

menu structure, 7-4

password protection, 8-3 to 8-4

record of user settings, B-1 to B-2

Parts, replacement, F-1 to F-2

Password Lockout Enable (F-20), 8-14

Password protection, 8-3 to 8-4

Percent Selected Speed Reference Display Enable  
(F-13), 8-11

Planning

drive clearance, 3-4

location, 3-1

Power

loss, 2-7 to 2-8

ratings, 2-7 to 2-8

wire sizes, 3-4 to 3-5

Power Module

checking circuitry with power off, 6-1 to 6-2

verifying DC voltage, 9-1 to 9-2



Power-Up Start Enable (F-19), 8-13  
Program mode, 7-4 to 7-5

## R

### Ratings

AC input, 2-7 to 2-8  
NEMA, 2-7 to 2-8  
power, 2-7 to 2-8  
power loss, 2-7 to 2-8  
Regulator board, 2-9 to 2-12, F-1 to F-2  
Remote Reference Gain (F-11), 8-9 to 8-10  
Remote Reference Offset (F-12), 8-10  
Replacement parts, F-1 to F-2  
Reset, digital input, 5-3, 5-7  
Resistor, snubber braking, 2-13, 4-2 to 4-5,  
5-8 to 5-9, A-2  
Reverse, digital input, 5-3, 5-7  
Reverse Disable (F-17), 8-12  
Routing, wire, 4-1 to 4-5  
RPM at Base Speed (F-08), 8-8  
RPM Setpoint Enable (F-18), 8-13

## S

Scaling the RPM display and reference, 7-6  
Signal wiring, 5-3 to 5-10  
Site requirements, 3-1  
Snubber resistor braking, 2-13, 4-2 to 4-5, 5-8 to  
5-9, A-2  
Specifications  
conduit opening sizes, 4-2 to 4-5  
environmental, 3-1, A-1  
dimensions, 3-2 to 3-3, A-1  
drive inputs, A-2  
drive outputs, A-2  
service conditions, A-1  
terminal torque ratings, 3-5  
wire sizes, 3-4 to 3-5  
Start, digital input, 5-5 to 5-7  
Stop, digital input, 5-5 to 5-7  
Stopping the drive, 3-9

## T

Terminal strip  
torque specifications, 3-5  
wire sizes, 3-4 to 3-5  
wiring, 5-3 to 5-10  
Testing, IGBT, 9-7 to 9-10  
Torque specifications, 3-5  
Transformer, isolation, 4-6 to 4-7

## V

Ventilation, *see* Air Flow  
Version Information (F-49), 8-17  
V/Hz (Base Speed) (F-07), 8-7 to 8-8

## W

Watts loss rating, 2-7 to 2-8  
Weights, A-1  
Wire routing, 4-1 to 4-5





U.S. Allen-Bradley Drives Technical Support - Tel: (1) 262.512.8176, Fax: (1) 262.512.2222, Email: support@drives.ra.rockwell.com, Online: www.ab.com/support/abdrives

**[www.rockwellautomation.com](http://www.rockwellautomation.com)**

---

**Power, Control and Information Solutions Headquarters**

Americas: Rockwell Automation, 1201 South Second Street, Milwaukee, WI 53204-2496 USA, Tel: (1) 414.382.2000, Fax: (1) 414.382.4444

Europe/Middle East/Africa: Rockwell Automation, Pegasus Park, De Kleetlaan 12a, 1831 Diegem, Belgium, Tel: (32) 2 663 0600, Fax: (32) 2 663 0640

Asia Pacific: Rockwell Automation, Level 14, Core F Cyberport 3, 100 Cyberport Road, Hong Kong, Tel: (852) 2887 4788, Fax: (852) 2508 1846