

GE Fanuc IC695ALG600

<http://www.pdfsupply.com/automation/ge-fanuc/rx3i-pacsystem/IC695ALG600>

Rx3i PacSystem

UNIVERSAL ANALOG MODULE. 8 CHANNELS OF ANALOG
CONFIGURABLE IC695A IC695AL IC695ALG

919-535-3180
sales@pdfsupply.com

Universal Analog Input Module, 8 Inputs, RTD, Thermocouple, Resistance, Current/Voltage: IC695ALG600

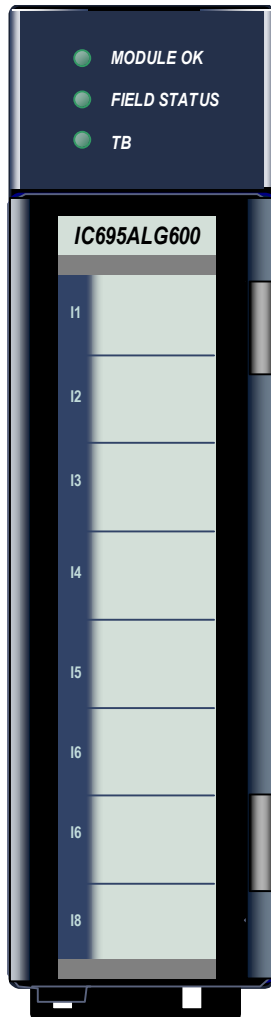

Universal Analog Input module IC695ALG600 provides eight general purpose input channels and two Cold Junction Compensation (CJC) channels. Inputs are divided into two equal groups of four. Channels can be individually-configured using the Machine Edition software for:

- Any combination of up to 8 channels of voltage, current, thermocouple, RTD, and resistance inputs.
- Thermocouple Inputs: B, C, E, J, K, N, R, S, T
- RTD Inputs: PT 385 / 3916, N 618 / 672, NiFe 518, CU 426
- Resistance Inputs: 0 to 250 / 500 / 1000 / 2000 / 3000 / 4000 Ohms
- Current: 0–20 mA, 4–20 mA, ± 20 mA
- Voltage: ± 50 mV, ± 150 mV, 0–5 V, 1–5 V, 0–10 V, ± 10 V

Module Features

- Completely software-configurable, no module jumpers to set
- Six hardware analog-to-digital filter frequencies, individually-selectable by channel
- Rapid channel acquisition times based on filter frequency
- Full autocalibration
- On-board error-checking
- Open-circuit detection for most input types
- Short-circuit detection for RTDs.
- User-defined scaling
- High alarm, low alarm, high-high alarm, low-low alarm detection and reporting
- Module fault reporting
- Supports diagnostic point fault contacts in the logic program.
- Flash memory for future upgrades
- Module Status, Field Status, and TB LEDs
- CJC compensation on terminal block
- Temperature in Celsius or Fahrenheit
- Positive and negative Rate of Change Alarms
- Configurable software filters for each input channel
- Configurable interrupts for channel alarms and faults
- Terminal Block insertion or removal detection

This module must be located in an RX3i Universal Backplane. It cannot be located in an expansion or remote backplane.

CIMPLICITY® Machine Edition 5.0 SP1A LD-PLC Hotfix 1 or later must be used to configure and program a PACSystems RX3i system that includes this module. The CPU must be RX3i model IC695CPU310 Firmware Revision 2.80 (Build ID 43A1) or later.

Specifications: ALG600

Backplane Power Requirements	400 mA maximum @ 5V 350 mA maximum @ 3.3V	
CPU Memory Usage	40 bytes (20 words) of input references for channel input data. 40 bytes for enhanced diagnostics 4 bytes for module status reporting.	
Power Dissipation within Module	5.4 watts maximum	
LEDs	One green LED to indicate the module status One bi-color green/yellow LED to indicate the field status One bi-color red/green LED to indicate the terminal block status	
Channel Acquisition Time	10 msec @ 1000 Hz, 13 msec @ 200 Hz, 27 msec @ 40 Hz, 67 msec @ 16 Hz, 87 msec @ 12 Hz, 127 msec @ 8 Hz	
Channel Update Time	The sum of the channel acquisition times for a bank of 4 channels plus one of the following if applicable: 1. RTD Lead resistance measurement time (equals channel acquisition time) 2. CJC acquisition time 7 msec.	
Input resolution	11 to 16 bits, depending on configured range and A/D filter frequency. See page 12-17 for details.	
<i>Inputs in Ohms</i>	Resistance	0-250, 0-500, 0-1000, 0-2000, 0-3000, 0-4000
	Platinum 385	100, 200, 500, 1000
	Platinum 3916	100, 200, 500, 1000
	Nickel 672	120
	Nickel 618	100, 200, 500, 1000
	Nickel-Iron 518	604
	Copper 426	10
<i>RTD Inputs</i>	Copper 426	-100 to 260 degrees C
	Nickel 618	-100 to 260 degrees C
	Nickel 672	-80 to 260 degrees C
	Nickel-Iron 518	-100 to 200 degrees C
	Platinum 385	-200 to 850 degrees C
	Platinum 3916	-200 to 630 degrees C
<i>Thermocouple Inputs</i>	Type B	300 to 1820 degrees C
	Type C	0 to 2315 degrees C
	Type E	-270 to 1000 degrees C
	Type J	-210 to 1200 degrees C
	Type K	-270 to 1372 degrees C
	Type N	-210 to 1300 degrees C
	Type R	0 to 1768 degrees C
	Type S	0 to 1768 degrees C
	Type T	-270 to 400 degrees C

Specifications, continued

Voltage / Current Inputs	-10V to +10V, 0V to +10V, 0 V to +5V, 1V to +5V, -50mV to +50mV, -150mV to +150mV, -20mA to +20mA, 4 to 20 mA, 0 to 20 mA
Configurable Input Filter	8Hz, 12Hz, 16Hz, 40Hz, 200Hz, 1000Hz
Scaling	Floating point user scaling.
Max RTD Cable Impedance	25 ohms
RTD Wire Length	1000 ft max w/settling time of 1mSec
Input Impedance	>1M ohm for Tc/V/RTD
Current Input Resistance	249 ohms +/- 1%
Open circuit detection time	5 seconds max. Open circuit detection is available for all configurations except +/-20mA current, 0-20mA current, and +/-10V voltage.
Max Overvoltage	+/-14.5VDC continuous
Max Overcurrent	28mA continuous
Normal Mode Noise Rejection	95 dB minimum @ 50/60 Hz with 8 Hz filter 85 dB minimum @ 50/60 Hz with 12 Hz filter
Common Mode Noise Rejection	120dB minimum @ 50/60 Hz with 8 Hz filter 110dB minimum @ 50/60 Hz with 12 Hz filter
Settling time to 5% of Full Scale (notch filter dependent)	<80mS
Calibrated Accuracy at 25°C	Better than 0.1% of range (except 10 ohm CU RTD) Accuracy depends on A/D filter, data format, input noise, and ambient temperature.
Calibration interval	12 months typical to meet accuracy specifications over time. Module will allow for user offset to be applied as a periodic calibration adjustment.
Input Offset Drift with Temperature	3.0 milliohm/°C maximum 2.0 uV/°C maximum
Gain Drift with Temperature	50 ppm/°C typical (90 ppm/°C maximum)
Module error over Full Temp range	0.5% of range typical (depends on range) 1.0% of range maximum
Module Scan Time (notch filter dependent)	(Assumes 2 ADC's running in parallel, no CJC or lead resistance) 10ms per Channel * 4 Channels = 40ms (1KHz filter) 127ms per Channel * 4 Channels = 508ms (8Hz filter) Channels that are disabled are not scanned, shortening scan time.
Module conversion method	Sigma-delta
Isolation Voltage channel to channel group to group terminal block to backplane/chassis	Opto-isolated, transformer isolated +/-12.5Vdc channel to channel Tc/V/I/RTD 250 VAC continuous/1500 VAC for 60 seconds 250 VAC continuous/1500 VAC for 60 seconds

Accuracy Specifications							
Maximum Error at:		+25°C			0°C to +60°C		
Configured Input Filter		8, 12, 16Hz	200Hz	1000Hz	8, 12, 16Hz	200Hz	1000Hz
Voltage Inputs*	+/- 10.5 V, 0.0 to +10.5 V	+/- 5 mV	+/- 5.5 mV	+/- 7 mV	+/- 10 mV	+/- 11 mV	+/- 14 mV
	0 to +5.25 V, +1.0 to +5.25 V	+/- 3 mV	+/- 3.3 mV	+/- 4.2 mV	+/- 5 mV	+/- 5. mV	+/- 7 mV
	+/- 155 mV	+/- 30 uV	+/- 33 uV	+/- 42 uV	+/- 110 uV	+/- 121 uV	+/- 154 uV
	+/- 55 mV	+/- 15 uV	+/- 17 uV	+/- 21 uV	+/- 70 uV	+/- 77 uV	+/- 98 uV
Current Inputs*	+/- 22.5 mA, 0.0 to +22.5 mA, +3.0 to +22.5 mA	+/- 20 uA	+/- 22 uA	+/- 28 uA	+/- 40 uA	+/- 44 uA	+/- 56 uA
Thermocouple Inputs*	Type J (-180°C to +1200°C)	+/- 0.6°C	+/- 0.7°C	+/- 0.9°C	+/- 2.3°C	+/- 2.6°C	+/- 3.3°C
	Type J (-210°C to -180°C)	+/- 0.8°C	+/- 0.9°C	+/- 1.2°C	+/- 3.3°C	+/- 3.7°C	+/- 4.7°C
	Type N (-160°C to +1300°C)	+/- 1.0°C	+/- 1.1°C	+/- 1.4°C	+/- 4.5°C	+/- 5.0°C	+/- 6.3°C
	Type N (-210°C to -160°C)	+/- 1.8°C	+/- 2.0°C	+/- 2.6°C	+/- 8.0°C	+/- 8.8°C	+/- 11.2°C
	Type T (-190°C to +400°C)	+/- 0.9°C	+/- 1.0°C	+/- 1.3°C	+/- 4.0°C	+/- 4.4°C	+/- 5.6°C
	Type T (-270°C to -190°C)	+/- 6.7°C	+/- 7.4°C	+/- 9.4°C	+/- 18.0°C	+/- 19.8°C	+/- 25.2°C
	Type K (-200°C to +1372°C)	+/- 1.0°C	+/- 1.1°C	+/- 1.4°C	+/- 4.0°C	+/- 4.4°C	+/- 5.6°C
	Type K (-270°C to -200°C)	+/- 9.5°C	+/- 10.5°C	+/- 13.3°C	+/- 21.0°C	+/- 23.1°C	+/- 29.4°C
	Type E (-200°C to +1000°C)	+/- 0.6°C	+/- 0.7°C	+/- 0.9°C	+/- 2.5°C	+/- 2.8°C	+/- 3.5°C
	Type E (-270°C to -200°C)	+/- 5.3°C	+/- 5.8°C	+/- 7.5°C	+/- 14.0°C	+/- 15.4°C	+/- 19.6°C
	Type S and R	+/- 2.8°C	+/- 3.1°C	+/- 4.0°C	+/- 11.5°C	+/- 12.7°C	+/- 16.1°C
	Type C	+/- 1.7°C	+/- 1.9°C	+/- 2.4°C	+/- 7.0°C	+/- 7.7°C	+/- 9.8°C
Type B	+/- 3.3°C	+/- 3.7°C	+/- 4.5°C	+/- 20.0°C	+/- 22.0°C	+/- 28.0°C	
RTD Inputs*	100 Ω Platinum 385	+/- 0.7°C	+/- 0.8°C	+/- 1.0°C	+/- 1.2°C	+/- 1.4°C	+/- 1.7°C
	200 Ω Platinum 385	+/- 0.6°C	+/- 0.7°C	+/- 0.9°C	+/- 1.0°C	+/- 1.1°C	+/- 1.4°C
	500 Ω Platinum 385	+/- 0.5°C	+/- 0.6°C	+/- 0.7°C	+/- 0.9°C	+/- 1.0°C	+/- 1.3°C
	1000 Ω Platinum 385	+/- 0.5°C	+/- 0.6°C	+/- 0.7°C	+/- 0.9°C	+/- 1.0°C	+/- 1.3°C
	100 Ω Platinum 3916	+/- 0.6°C	+/- 0.7°C	+/- 0.9°C	+/- 1.1°C	+/- 1.2°C	+/- 1.6°C
	200 Ω Platinum 3916	+/- 0.5°C	+/- 0.6°C	+/- 0.7°C	+/- 0.9°C	+/- 1.0°C	+/- 1.3°C
	500 Ω Platinum 3916	+/- 0.4°C	+/- 0.5°C	+/- 0.6°C	+/- 0.8°C	+/- 0.9°C	+/- 1.2°C
	1000 Ω Platinum 3916	+/- 0.4°C	+/- 0.5°C	+/- 0.6°C	+/- 0.8°C	+/- 0.9°C	+/- 1.2°C
	Nickel 672	+/- 0.3°C	+/- 0.4°C	+/- 0.5°C	+/- 0.5°C	+/- 0.6°C	+/- 0.7°C
	Nickel 618	+/- 0.3°C	+/- 0.6°C	+/- 0.5°C	+/- 0.5°C	+/- 0.6°C	+/- 0.7°C
	Nickel-Iron 518	+/- 0.4°C	+/- 0.5°C	+/- 0.6°C	+/- 0.7°C	+/- 0.8°C	+/- 1.0°C
	Copper 426	+/- 1.0°C	+/- 1.1°C	+/- 1.4C	+/- 2.4 °C	+/- 2.7 °C	+/- 3.4 °C
Resistance Inputs*	250 ohms	+/- 0.25 Ω	+/- 0.28 Ω	+/- 0.35 Ω	+/- 0.35 Ω	+/- 0.39 Ω	+/- 0.49 Ω
	500 ohms	+/- 0.3 Ω	+/- 0.33 Ω	+/- 0.42 Ω	+/- 0.45 Ω	+/- 0.5 Ω	+/- 0.63 Ω
	1000 ohms	+/- 0.5 Ω	+/- 0.55 Ω	+/- 0.7 Ω	+/- 0.8 Ω	+/- 0.88 Ω	+/- 1.2 Ω
	2000 ohms	+/- 0.9 Ω	+/- 1.0 Ω	+/- 1.26 Ω	+/- 1.5 Ω	+/- 1.65 Ω	+/- 2.1 Ω
	3000 ohms	+/- 1.3 Ω	+/- 1.43 Ω	+/- 1.82 Ω	+/- 2.2 Ω	+/- 2.42 Ω	+/- 3.08 Ω
	4000 ohms	+/- 1.7 Ω	+/- 1.87 Ω	+/- 2.38Ω	+/- 2.9 Ω	+/- 3.19 Ω	+/- 4.06 Ω
Cold Junction Temperature	+/- 1.5°C maximum						
CJC Sensor	+/- 0.3°C maximum 0°C to +80°C						

* Accuracy is dependent on the ADC output rate selection, data format, and input noise. In severe RF environments, accuracy may be degraded by up to +/-2% of full scale.

Field Wiring: ALG600

The table below lists wiring connections for the module. Except for RTD and resistance type inputs, channels are wired as differential inputs. There are no shield terminals. For shielding, tie cable shields to the ground bar along the bottom of the backplane. M3 tapped holes are provide in the ground bar for this purpose.

Terminal	RTD or Resistance	TC / Voltage / Current	RTD or Resistance	TC / Voltage / Current	Terminal
1		CJC1 IN+	Channel 1 EXC+		19
2		CJC1 IN-	Channel 1 IN+	Channel 1 IN+	20
3	Channel 2 EXC+			Channel 1 iRTN	21
4	Channel 2 IN+	Channel 2 IN+	Channel 1 IN-	Channel 1 IN -	22
5		Channel 2 iRTN	Channel 3 EXC+		23
6	Channel 2 IN-	Channel 2 IN -	Channel 3 IN+	Channel 3 IN+	24
7	Channel 4 EXC+			Channel 3 iRTN	25
8	Channel 4 IN+	Channel 4 IN+	Channel 3 IN-	Channel 3 IN-	26
9		Channel 4 iRTN	Channel 5 EXC+		27
10	Channel 4 IN-	Channel 4 IN -	Channel 5 IN+	Channel 5 IN+	28
11	Channel 6 EXC+			Channel 5 iRTN	29
12	Channel 6 IN+	Channel 6 IN+	Channel 5 IN-	Channel 5 IN-	30
13		Channel 6 iRTN	Channel 7 EXC+		31
14	Channel 6 IN-	Channel 6 IN-	Channel 7 IN+	Channel 7 IN+	32
15	Channel 8 EXC+			Channel 7 iRTN	33
16	Channel 8 IN+	Channel 8 IN+	Channel 7 IN-	Channel 7 IN-	34
17		Channel 8 iRTN		CJC2 IN+	35
18	Channel 8 IN-	Channel 8 IN-		CJC2 IN-	36

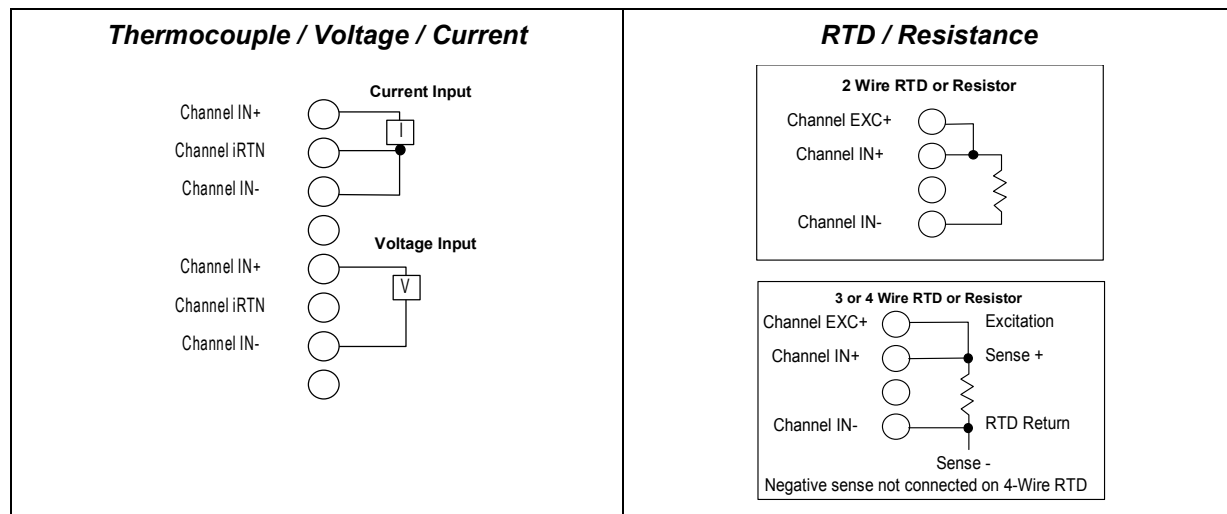

- For current inputs, tie the Return to the associated IN- pin.
- For 2 wire RTDs, tie EXC+ and IN+ together at the terminal block.
- For 4 wire RTDs, leave one of the negative sense leads unconnected.
- For 3 wire RTDs, IN+ = Sense+, IN- = RTD Return, and EXC+ = Excitation current.

Installing CJC Sensors

When using any thermocouple inputs on this module, the use of CJC sensors is recommended. Installing one CJC sensor will greatly improve the accuracy of thermocouple readings. Installing two CJC sensors will provide the highest thermocouple input accuracy for the module. See “CJC Scan Enable” later in this chapter for information about configuring and using CJC sensors.

A CJC sensor compensates for offset voltages introduced into the input signal where the thermocouple wires are connected to the module. A set of two CJC sensors is available as part number IC695ACC600.

The thermistor end of the CJC sensor must be installed in the CJC1 IN+ or CJC2 IN+ terminal for accurate thermocouple temperature measurements. The gold pin end of the CJC sensor must be installed in the CJC1 IN- or the CJC2 IN- terminal.

Open the Terminal Block contacts fully before installing the CJC sensor. Insert the sensor into the Terminal Block contact, maintaining metal-to-metal contact between the thermistor and the Terminal Block contact.

For a Box-style Terminal Block, maintain pressure while screwing down the contact.

Connecting Channels to the Same Thermocouple Point

When connecting one or more channels from channels 1 - 4 and one or more channels from channels 5 - 8 to the same thermocouple point electrically, the point should be grounded. It can be grounded at either the sensor or the module, by adding a jumper wire from frame ground to the low side of one thermocouple input.

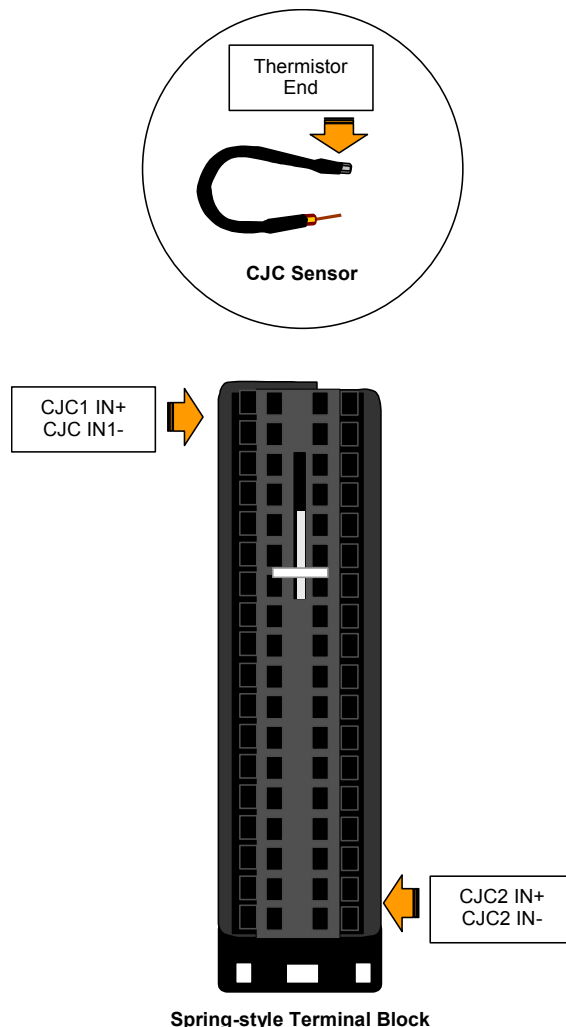

Configuration Parameters: ALG600

Module Parameters		
Parameter	Default	Description
Channel Value Reference Address	%AIxxxxx	Starting address for the module's input data. This defaults to the next available %AI block.
Inputs Default	Force Off	In the event of module failure or removal, this parameter specifies the state of the Channel Value References. Force Off = Channel Values clear to 0. Hold Last State = Channel Values hold their last state.
Channel Value Reference Length	20	The number of words used for the module's input data
Diagnostic Reference Address	%Ixxxxx	Starting address for the channel diagnostics status data. This defaults to the next available %I block.
Diagnostic Reference Length	0	The number of bit reference bits (0 – 320) required for the Channel Diagnostics data. Default is 0, which means mapping of Channel Diagnostics is disabled. Change this to a non-zero value to enable Channel Diagnostics mapping.
Module Status Reference Address	%Ixxxxx	Starting address for the module's status data. This defaults to the next available %I block.
Module Status Reference Length	0	The number of bits (0 – 32) required for the Module Status data. Default is 0, which means mapping of Module Status data is disabled. Change this to a non-zero value to enable Module Status data mapping.
CJC Scan Enable	Disabled	Cold Junction Compensation can be: No Scan, Scan CJC1, Scan CJC2, Scan Both CJCs. Use of these parameters is described later in this section.
Channel Faults w/o Terminal Block	Disabled	Enabled / Disabled: Controls whether channel faults and configured alarm responses will be generated after a Terminal Block removal. The default setting of Disabled means channel faults and alarms are suppressed when the Terminal Block is removed. This parameter does not affect module faults including the Terminal Block loss/add fault generation.
I/O Scan Set	1	The scan set 1 – 32 to be assigned to the module by the RX3i CPU

Channel 1 – 8 Parameters		
Parameter	Default	Description
Range Type	Disabled	Voltage/Current, Thermocouple, RTD, Resistance, Disabled
Range (Not for Range Type Disabled)	-10V to +10V	For voltage/current: -10V to +10V, 0V to +10V, 0V to +5V, 1V to +5V, -50mV to +50mV, -150mV to +150mV, -20mA to +20mA, 4 to 20 mA, 0 to 20 mA
		For Thermocouple: B, C, E, J, K, N, R, S, T
		For RTD: Platinum 385, 100 ohm / 200 ohm / 500 ohm / 1000 ohm, Platinum 3916, 100 ohm / 200 ohm / 500 ohm / 1000 ohm, Nickel 672, 120 ohms, Nickel 618, 100 ohms / 200 ohms / 500 ohms / 1000 ohms, Nickel-Iron 518, 604 ohms, Copper 426, 10 ohms
		For Resistance: 0-250 Ohm, 0 – 500 Ohm, 0 – 1000 Ohm, 0 – 2000 Ohm, 0 – 3000 Ohm, 0 – 4000 Ohm
Channel Value Format	32-bit Floating Point	16-bit integer or 32-bit floating point
Temperature Units (for Thermocouple or RTD Range Type only)	Celsius	Celsius, Fahrenheit
RTD	RTD 2 Wire	(for RTD Range Type only) RTD 2 or 3 Wire
RTD Lead Resistance Compensation	Enabled	(for RTD Range Type only)Enabled, Disabled
High Scale Value (Eng Units)	The defaults for the 4 Scaling parameters depend on the configured Range Type and Range. Each Range and Range Type have a different set of defaults.	Note: Scaling is disabled if both High Scale Eng. Units equals High Scale A/D Units and Low Scale Eng. Units equals Low Scale A/D Units. Default is High A/D Limit of selected range type.
Low Scale Value (Eng Units)		Default is Low A/D Limit of selected range type. Must be lower than the high scaling value.
High Scale Value (A/D Units)		Default is High A/D Limit of selected range type. Must be greater than the low scaling value.
Low Scale Value (A/D Units)		Default is Low A/D Limit of selected range type.

Input Scaling

By default, the module converts a voltage, current, resistance, or temperature input over the entire span of its configured Range into a floating point value for the CPU. For example, if the Range of a channel is 4 to 20mA, the module reports channel input values from 4.000 to 20.000. By modifying one or more of the four channel scaling parameters (Low/High Scale Value parameters) from their defaults, the scaled Engineering Unit range can be changed for a specific application. Scaling can provide inputs to the PLC that are already converted to their physical meaning, or convert input values into a range that is easier for the application to interpret. Scaling is always linear and inverse scaling is possible. All alarm values apply to the scaled Engineering Units value, not to the A/D input value.

The scaling parameters only set up the linear relationship between two sets of corresponding values. They do not have to be the limits of the input.

Example 1

For a voltage input, 6.0 volts equals a speed of 20 feet per second, and 1.0 volt equals 0 feet per second. The relationship in this range is linear. For this example, the input values should represent speed rather than volts. The following channel configuration sets up this scaling:

High Scale Value (Eng Units) = 20.000

Low Scale Value (Eng Units) = 0.000

High Scale Value (A/D Units) = 6.000

Low Scale Value (A/D Units) = 1.000

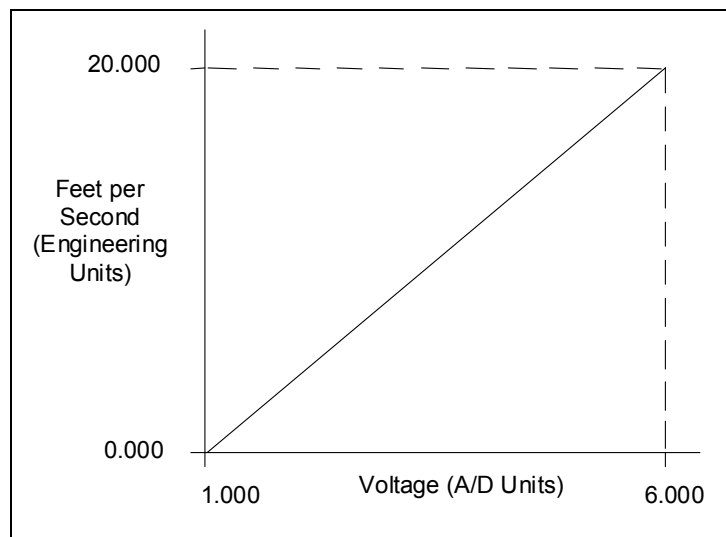

For this example, 1.0V to 6.0V is the normal voltage range, but the module will attempt to scale the inputs for a voltage that lies outside the range. If a voltage of 10.0V were input to the channel, the module would return a scaled channel value of 36.000. The application should use alarms or take other precautions for scaled inputs that are outside the acceptable range or invalid.

Example 2

An existing application uses traditional analog to digital (A/D) count integer values. With scaling and the optional 16-bit integer input option, a channel can be configured to report integer count values. In this example, the application should interpret +10V as 32000 counts and -10V as -32000 counts. The following channel configuration will scale a +/-10V input channel to +/- 32000 counts.

Channel Value Format = 16 Bit Integer
High Scale Value (Eng Units) = 32000.0
Low Scale Value (Eng Units) = -32000.0
High Scale Value (A/D Units) = 10.000
Low Scale Value (A/D Units) = -10.000

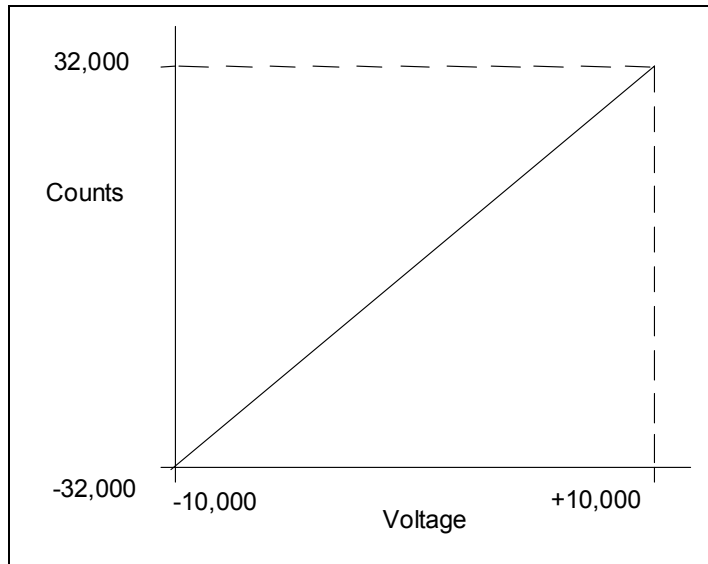

Channel 1 – 8 Parameters continued		
Parameter	Default	Description
Positive Rate of Change Limit (Eng Units)	0.000	Rate of change in Engineering Units per Second that will trigger a Positive Rate of Change alarm. Default is disabled. Used with “Rate of Change Sampling Rate” parameter.
Negative Rate of Change Limit (Eng Units)	0.000	Rate of change in Engineering Units per Second that will trigger a Negative Rate of Change alarm. Default is disabled. Used with “Rate of Change Sampling Rate” parameter.
Rate of Change Sampling Rate	0.000	Time from 0 to 300 seconds to wait between comparisons. Default of 0.0 is to check after every input sample.

Rate of Change Alarms

The Universal Analog module can detect both Negative Rate of Change and Positive Rate of Change in Engineering Units per Second. When either of the Rate of Change parameters is configured to be non-zero, the module takes the difference in Engineering Units between the previous rate of change sample and the current sample, then divides by the elapsed time between samples.

If the Engineering Unit change from the previous sample to current sample is negative, the module compares the rate change with the Negative Rate of Change parameter.

If the Engineering Unit change between samples is positive, the module compares the results in comparing the rate change with the Positive Rate of Change parameter value.

In either case, if the rate of change is greater than the configured rate, a rate of change alarm occurs. The actions taken by the module following the alarm depend on the enabled rate of change actions that have been set up in the "Diagnostic Reporting Enable", "Fault Reporting Enable", and "Interrupts Enabled" parameters.

The Rate of Change Sampling Rate parameter determines how frequently the module compares the Rate of Change. If the Rate of Change Sampling Rate is 0 or any time period less than the channel update rate, the module compares the Rate of Change for every input sample of the channel.

Channel 1 – 8 Parameters continued		
Parameter	Default	Description
High-High Alarm (Eng Units)	The defaults for the High-High, High, Low, and Low-Low parameters depend on the configured Range Type and Range. Each Range and Range Type has a different set of default values.	<p>Alarms and Deadbands</p> <p>All of the alarm parameters are specified in Engineering Units. To use alarming, the A/D Alarm Mode must also be configured as enabled.</p> <p><i>High-High Alarm and Low-Low Alarm:</i> When the configured value is reached or passed, a Low-Low Alarm or High-High Alarm is triggered. The configured values must be lower than/higher than the corresponding low/high alarm limits.</p> <p><i>High Alarm and Low Alarm:</i> When the configured value is reached or below (above), a Low (High) Alarm is triggered.</p> <p><i>High and Low Alarm Deadbands:</i> A range in Engineering Units above the alarm condition (low deadband) or below the alarm condition (high deadband) where the alarm status bit can remain set even after the alarm condition goes away. For the alarm status to clear, the channel input must fall outside the deadband range.</p> <p>Alarm Deadbands should not cause the alarm clear to be outside the Engineering Unit User Limits range. For example, if the engineering unit range for a channel is -1000.0 to +1000.0 and a High Alarm is set at +100.0, the High Alarm Deadband value range is 0.0 to less than 1100.0. A deadband of 1100.0 or more would put the High Alarm clear condition below -1000.0 units making the alarm impossible to clear within the limits.</p>
High Alarm (Eng Units)		
Low Alarm (Eng Units)		
Low-Low Alarm (Eng Units)		
High-High Alarm Deadband (Eng Units)		
High Alarm Deadband (Eng Units)		
Low Alarm Deadband (Eng Units)		

Channel 1 – 8 Parameters continued		
Parameter	Default	Description
User Offset	0.000	Engineering Units offset to change the base of the input channel. This value is added to the scaled value on the channel prior to alarm checking.
Software Filter Integration Time in milliseconds.	0.000	Specifies the amount of time in milliseconds for the software filter to reach 63.2% of the input value. A value of 0 indicates software filter is disabled. A value of 100 indicates data will achieve 63.2% of its value in 100ms. Default is disabled
A/D Filter Frequency	40 Hz	Low pass A/D hardware filter setting: 8, 12,16,40,200,or 1000Hz. Default is 40Hz. Frequencies below this are not filtered by hardware.
Diagnostic Reporting Enable <i>If Diagnostic Reporting is enabled, the additional parameters listed below can be used to enable specific types of alarms.</i>	Disabled	<i>Diagnostic Reporting Enable options</i> are used to enable reference memory reporting of alarms into the Diagnostic Reference area. <i>Fault Reporting Enable options</i> enable fault logging of alarms into the I/O Fault Table. <i>Interrupts Enable options</i> enable I/O Interrupt trigger when alarm conditions occur.
Fault Reporting Enable <i>If Fault Reporting is enabled, the additional parameters listed below can be used to enable specific types of Faults.</i>	Disabled	These parameters enable or disable the individual diagnostics features of a channel. When any of these parameters is enabled, the module uses associated parameters to perform the enabled feature.
Interrupts Enable <i>If Interrupts are enabled, the additional parameters listed below can be used to enable specific types of Interrupts.</i>	Disabled	
Low Alarm Enable	Disabled	
High Alarm Enable	Disabled	
Under Range Enable	Disabled	
Over Range Enable	Disabled	
Open Wire Enable	Disabled	
Calibration Fault Enable	Disabled	
Low-Low Alarm Enable	Disabled	
High-High Alarm Enable	Disabled	
Negative Rate of Change Detection Enable	Disabled	
Positive Rate of Change Detection Enable	Disabled	

If any of these parameters is disabled, the module does not react to the associated alarm conditions.

For example, if Low Alarm Enable is set to Disabled in the “Fault Reporting Enable” menu, the Low Alarm fault is not logged in the I/O Fault Table when Low Alarm is detected on the channel.

Using Alarming

The Diagnostic Reporting Enable, Fault Reporting Enable, and Interrupt Enable configuration parameters can be used to enable different types of responses for individual channel alarms. By default, all responses are disabled on every channel. Any combination of alarm enables can be configured for each channel.

- If Diagnostic Reporting is enabled, the module reports channel alarms in reference memory at the channel's Diagnostic Reference address.
- If Fault Reporting is enabled, the module logs a fault log in the I/O Fault table for each occurrence of a channel alarm.
- If Interrupts are enabled, an alarm can trigger execution of an Interrupt Block in the application program, as explained below.

Using Interrupts

To properly configure an I/O Interrupt, the Interrupt enable bit or bits must be set in the module's configuration. In addition, the program block that should be executed in response to the channel interrupt must be mapped to the corresponding channel's reference address.

Example:

In this example, the Channel Values Reference Address block is mapped to %AI0001-%AI0020. An I/O Interrupt block should be triggered if a High Alarm condition occurs on channel 2.

- Configure the High-Alarm condition.
- Set the High-Alarm Interrupt Enable flag for Channel 2 in the module configuration.

Channel 2's reference address corresponds to %AI00003 (2 Words per channel), so the interrupt program block Scheduling properties should be set for the "I/O Interrupt" Type and "%AI0003" as the Trigger.

Note on Using Interrupts

This module has separate enable/disable options for Diagnostic Reporting and Interrupts. Normally, disabling a diagnostic (such as Low/High Alarm or Over/Under range) in the configuration means that its diagnostic bit is never set. However, if interrupts are enabled for a condition and that interrupt occurs, the diagnostic bit for that condition is also set during the I/O Interrupt block logic execution. The next PLC input scan always clears this interrupt status bit back to 0, because Diagnostic Reporting has it disabled.

CJC Parameters		
Parameter	Default	Description
Channel Value Format	16-bit Integer	16-bit integer or 32-bit floating point
Temperature Units	Celsius	Celsius, Fahrenheit
User Offset (Temperature Units)	0.000	Temperature offset added to CJC values. Range –25 to +25 degC and -45 to +45 degF in F temp mode.
Diagnostic Reporting Enable	Disabled	These parameters enable or disable the individual diagnostics features of a CJC input.
Under Range Enable	Disabled	
Over Range Enable	Disabled	
Open Wire Enable	Disabled	
Fault Reporting Enable	Disabled	
Under Range Enable	Disabled	
Over Range Enable	Disabled	
Open Wire Enable	Disabled	
Interrupts Enable	Disabled	
Under Range Enable	Disabled	
Over Range Enable	Disabled	
Open Wire Enable	Disabled	

CJC Scan Enable

Cold Junction Compensation for the module can be configured as: Disabled, CJC1 only, CJC2 only, or Both CJCs.

Compensation Options	Description	CJC1 Scanning	CJC2 Scanning
No Scan	Module assumes 25 degrees C for any thermocouple compensation.	Disabled	Disabled
Scan Both	Highest thermocouple compensation accuracy. Uses both values in thermocouple compensation as explained below.	Enabled	Enabled
Scan CJC1 only.	Lowers the thermocouple compensation accuracy, but can improve scan time for channels 5-8.	Enabled	Disabled
Scan CJC2 only.	Lowers the thermocouple compensation accuracy, but can improve scan time for channels 1-4.	Disabled	Enabled

When scanning both CJC inputs, the module subtracts the temperature of CJC2 from the temperature of CJC1. It then multiplies the difference by a specific multiplier for each channel to compensate for the position of the channel on the terminal block.

Channel	Channel Multiplier	Channel	Channel Multiplier
1	0.10	5	0.45
2	0.05	6	0.60
3	0.25	7	0.75
4	0.25	8	0.90

For example: if CJC1 is 30 degrees Celsius and CJC2 is 25 degrees Celsius, the compensated channel 1 terminal block temperature is $30 - [(30-25) * 0.10] = 29.5$ degrees Celsius. The

module then adjusts this temperature for the particular thermocouple type to determine the thermoelectric effect (mV) caused by the connection at the terminal block.

Module Data: ALG600

The module reports its input channel data in 20 input words, beginning at its assigned Channel Value Reference Address. Each channel occupies 2 words (whether the channel is used or not):

Channel Value Reference Address	Contains this Input
+0, 1	Channel 1
+2, 3	Channel 2
+4, 5	Channel 3
+6, 7	Channel 4
+8, 9	Channel 5
+10, 11	Channel 6
+12, 13	Channel 7
+14, 15	Channel 8
+16, 17	CJC1
+18, 19	CJC2

Depending on its configured Channel Value Format, each enabled channel reports a 32-bit floating point or 16-bit integer value to the CPU.

In the 16-bit integer mode, low word of the 32-bit channel data area contains the 16-bit integer channel value. The high word (upper 16-bits) of the 32-bit value are set with the sign extension of the 16-bit integer. This sign-extended upper word allows the 16-bit integer to be read as a 32-bit integer type in logic without losing the sign of the integer. If the 16-bit integer result is negative, the upper word in the 32-bit channel data has the value 0xFFFF. If the 16-bit integer result is positive, the upper word is 0x0000.

Resolution and Update Time

The actual resolution and update time for each input depend on the channel's configured Range Type and A/D Filter Frequency. At higher Filter Frequencies, channel update time increases while input resolution decreases. The approximate number of bits for each Filter Frequency and Range Type are shown in the table below.

Filter Frequency	Range Type: Voltage / Current Approximate Number of Bits	Range Type: TC / mV Approximate Number of Bits	Channel Update Time
8 Hz	16	16	127 ms
12 Hz	16	16	87 ms
16 Hz	16	16	67 ms
40 Hz	16	14	27 ms
200 Hz	14	13	13 ms
1000 Hz	11	11	10 ms

Isolated Input Groups

This module provides two isolated groups of four input channels each. This allows fast inputs and slower or highly-filtered inputs to be connected to the same module without adversely affecting the update rate of the fast inputs. To take advantage of this feature, up to four inputs requiring fast response should be placed together in one isolated group while slower inputs should be connected to the other isolated group. For example, voltage and current inputs with higher frequency input filter settings should be grouped together on one of the isolated groups while thermocouple, RTD, resistance, or voltage/current inputs with low-frequency input filter settings should be grouped together on the other isolated group.

Each isolated group provides a CJC input. The CJC input is considered a slow-response input and will reduce the update rate for the associated channel group when enabled.

Channel Diagnostic Data: ALG600

In addition to the 20 words of input data from field devices, the module can be configured to report 320 bits (20 words) of channel diagnostics status data to the CPU. The CPU stores this data at the module’s configured *Diagnostic Reference Address*. Use of this feature is optional.

The diagnostics data for each channel occupies 2 words (whether the channel is used or not):

Diagnostic Reference Address	Contains Diagnostics Data for:
+0, 1	Channel 1
+2, 3	Channel 2
+4, 5	Channel 3
+6, 7	Channel 4
+8, 9	Channel 5
+10, 11	Channel 6
+12, 13	Channel 7
+14, 15	Channel 8
+16, 17	CJC1
+18, 19	CJC2

When a diagnostic bit equals 1, the alarm or fault condition is present on the channel. When a bit equals 0 the alarm or fault condition is either not present or detection is not enabled in the configuration for that channel.

For each channel, the format of this data is:

Bit	Description
1	Low Alarm
2	High Alarm
3	Underrange
4	Overrange
5	Open Wire
6 – 16	Reserved (set to 0).
17	Low-Low Alarm
18	High-High Alarm
19	Negative Rate of Change Alarm
20	Positive Rate of Change Alarm
21 - 32	Reserved (set to 0).

Module Status Data: ALG600

The module can also optionally be configured to return 2 bits of module status data to the CPU. The CPU stores this data in the module's 32-bit configured Module Status Data reference area.

Bit	Description
1	Module OK (1 = OK, 0 = failure, or module is not present)
2	Terminal Block Present (1 = Present, 0 = Not present)
3 - 32	Reserved

Terminal Block Detection

The module automatically checks for the presence of a Terminal Block.

The module's TB LED indicates the state of the terminal block. It is green when the Terminal Block is present or red if it is not.

Faults are automatically logged in the CPU's I/O Fault table when the terminal block is inserted or removed from a configured module in the system. The fault type is Field Fault and the fault description indicates whether the fault is a "Loss of terminal block" or an "Addition of terminal block". If a Terminal Block is not present while a configuration is being stored, a "Loss of terminal block" fault is logged.

Bit 1 of the Module Status Reference indicates the status of the terminal block. To enable Module Status reporting, the Module Status Reference must be configured. During operation, the PLC must be in an I/O Enabled mode for the current Module Status to be scanned and updated in reference memory.