



Product Manual 26167V3
(Revision NEW, 10/2016)
Original Instructions

MicroNet TMR Digital Control

Manual 26167 consists of 3 volumes (26167V1, 26167V2, & 26167V3).

Installation and Operation Manual

**General
Precautions**

Read this entire manual and all other pertinent publications prior to installing, operating, or servicing this equipment.

Practice all plant and safety instructions and precautions.

Failure to follow instructions can cause personal injury and/or property damage.

**Revisions**

This publication may have been revised or updated since this copy was produced. To verify that you have the latest revision, check manual **26455**, *Customer Publication Cross Reference and Revision Status & Distribution Restrictions*, on the *publications page* of the Woodward website:

www.woodward.com/publications

The latest version of most publications is available on the *publications page*. If your publication is not there, please contact your customer service representative to get the latest copy.

**Proper Use**

Any unauthorized modifications to or use of this equipment outside its specified mechanical, electrical, or other operating limits may cause personal injury and/or property damage, including damage to the equipment. Any such unauthorized modifications: (i) constitute "misuse" and/or "negligence" within the meaning of the product warranty thereby excluding warranty coverage for any resulting damage, and (ii) invalidate product certifications or listings.

**Translated
Publications**

If the cover of this publication states "Translation of the Original Instructions" please note:

The original source of this publication may have been updated since this translation was made. Be sure to check manual **26455**, *Customer Publication Cross Reference and Revision Status & Distribution Restrictions*, to verify whether this translation is up to date. Out-of-date translations are marked with . Always compare with the original for technical specifications and for proper and safe installation and operation procedures.

Revisions—A black line alongside the text highlights changes in this publication since the previous revision.

Woodward reserves the right to update any portion of this publication at any time. Information provided by Woodward is believed to be correct and reliable. However, no responsibility is assumed by Woodward unless otherwise expressly undertaken.

Manual 26167V3
Copyright © Woodward, Inc. 2016
All Rights Reserved

Contents

WARNINGS AND NOTICES	7
ELECTROSTATIC DISCHARGE AWARENESS	8
CHAPTER 1. GENERAL INFORMATION	9
Introduction	9
CHAPTER 2. CPUS	10
Introduction	10
2.1. CPU_040 Module	10
CHAPTER 3. COMMUNICATION	19
3.1. Main Transceiver (XCVR) Module	19
3.2. Remote Transceiver (XCVR) Module	20
3.3. Transceiver Accessories	23
3.4. Ethernet Module	25
CHAPTER 4. DISCRETE I/O MODULES	29
4.1. 24/12 TMR Discrete I/O Module	29
4.2. 48/24 Discrete Combo Module	42
4-3. 32 Channel Discrete Output Module	52
CHAPTER 5. ANALOG I/O MODULES	57
5.1. TMR 24/8 Analog Module	57
5.2. TMR Analog Combo Module – 3 MPU, 1 Prox	64
5.3. 24/8 Analog Module	79
5.4. Dataforth 24/8 Analog Module	85
5.5. 34 Ch. High Density Versatile Input Module (HDVIM)	94
5.6. Current Input Modules	103
5.7. 8 Ch. Current Input (4–20 mA) Module	103
5.8. Non-Standard 8Ch Current Input (4-20 mA) Module	108
5.9. Voltage Input Module	113
5.10. 8 Channel Voltage Input (0-10 Vdc) Module	113
5.11. Current Output Modules	117
5.12. 8Ch Current Output (4-20 mA) Module	117
5.13. 8Ch Current Output (0–1 mA) Module	121
5.14. Voltage Output Modules	123
5.15. 8Ch Voltage Output (0-5 Vdc) Module	123
5.16. 8Ch Voltage Output (0-10 Vdc) Module	126
5.17. Thermocouple Input Modules	128
5.18. 8Ch TC (Fail Low) Module	128
5.19. 8Ch TC (Fail High) Module	132
5.20. RTD Input Modules	134
5.21. 8Ch RTD Input (10 ohm)	134
5.22. 8Ch RTD Input (100 ohm)	139
5.23. 8Ch RTD Input (200 ohm)	140
5.24. 8Ch RTD Input (500 ohm)	142
5.25. 4Ch MPU/Proximity Module	143
CHAPTER 6. ACTUATOR MODULES	149
6.1. Four Channel Actuator Module	149
6.2. EM/TM Position Controller	151
CHAPTER 7. FIELD TERMINATION MODULES (FTMS)	155

7.1. Service Panel	155
7.2. CPU Interfaces	158

Illustrations and Tables

Figure 2-1. 040 CPU Module	10
Figure 2-1. CPU Module	11
Figure 2-2. CPU Module Block Diagram	12
Figure 2-3. 68040 CPU Communications Port	13
Figure 3-1. Main XCVR Module Block Diagram	19
Figure 3.2. Main XCVR Module	19
Figure 3-3. Remote XCVR Module Block Diagram	20
Figure 3-4. Remote XCVR Module Jumpers	21
Figure 3-5. Remote XCVR Module	22
Figure 3-6. T-Module (I/O XCVR-Module)	23
Figure 3-7. Cables [Available in 3 ft. (0.9 m) and 10 ft. (3 m) lengths]	23
Figure 3-8. Expansion I/O Chassis	24
Figure 3-9. Termination	25
Figure 3-10. Ethernet Module	26
Figure 4-1. 24/12 TMR Discrete I/O Module	29
Figure 4-2. 24/12 TMR Discrete I/O Module Block Diagram	30
Figure 4-3. Example TMR System Configuration	31
Figure 4-4. Wiring Diagram for a FT Relay/Discrete Input Module	32
Figure 4-5. Optional Internal 24 Vdc Contact Wetting Configuration	33
Figure 4-6. Optional External 24/125 Vdc Contact Wetting Configuration	34
Figure 4-7. TMR Discrete Output	35
Figure 4-8. Latent Fault Detection Verification Graph—18-32 Vdc Circuitry	37
Figure 4-9. Latent Fault Detection Verification Graph—18-132 Vac Circuitry	37
Figure 4-10. Latent Fault Detection Verification Graph—100–150 Vdc Circuitry	38
Figure 4-11. Jumper and Relay Location Diagram	39
Figure 4-12. FT Relay/Discrete Input Module Labels	39
Figure 4-13. Example Relay Output Wiring Diagram	40
Figure 4-14. Discrete Combo Module	43
Figure 4-15. Configuration 1, One 48/24 Discrete FTM with Relay Module(s)	44
Figure 4-16. Discrete Input Interface Wiring to a 24 Vdc 48/24 Discrete FTM	45
Figure 4-17. Discrete Input Interface Wiring to a 125 Vdc 48/24 Discrete FTM	45
Figure 4-18. Relay Output Interface Wiring to a 16 Ch. Relay Module	47
Figure 4-19. Relay Output Interface Wiring to a 32 Ch. Relay Module	47
Figure 4-20. Configuration 2, Two 24/12 Discrete FTMs	48
Figure 4-21. Discrete Input Interface Wiring to a 24/12 Discrete FTM	49
Figure 4-22. Relay Output Interface Wiring to a 24/12 Discrete FTM	50
Figure 4-23. 48/24 Discrete Combo Module Block Diagram	51
Figure 4-24. Discrete Output Module	53
Figure 4-25. 32 Ch. DO Module with Relay Modules	54
Figure 4-26. Relay Output Interface Wiring to a 16 Ch. Relay Module	54
Figure 4-27. Relay Output Interface Wiring to a 32 Ch. Relay Module	55
Figure 4-28. Discrete Output Module (32 Channel) Block Diagram	56
Figure 5-1. 24/8 Analog Module	57
Figure 5-2. Example TMR System Configuration	59
Figure 5-3. Analog Input Wiring for a 24/8 Analog FTM	60
Figure 5-4. Analog Output Wiring for a 24/8 Analog FTM	61
Figure 5-5. Analog Combo Module	64

Figure 5-6. Example Fault Tolerant System Configuration	66
Figure 5-7. MPU Interface Wiring to TMR Analog Combo FTM (Speed 1-3)	68
Figure 5-8. Prox Interface Wiring to TMR Analog Combo FTM (Speed 4)	68
Figure 5-9—Current Input Wiring for an Analog Combo Module FTM.....	69
Figure 5-10. Voltage Input Wiring for an Analog Combo Module FTM (Simplex)	70
Figure 5-11. Analog Output and Actuator Wiring for an Analog Combo FTM.....	72
Figure 5-12. TMR MPU and Analog I/O Module FTM Fuse Locations	78
Figure 5-13. Simplex MPU and Analog I/O Module FTM Fuse Locations	79
Figure 5-14. 24/8 Analog Module	80
Figure 5-15. Simplex System Configuration Example.....	81
Figure 5-16. Analog Input Wiring for a 24/8 Analog FTM.....	82
Figure 5-17. Analog Output Wiring for a 24/8 Analog FTM.....	83
Figure 5-18. Dataforth 24/8 Analog Module	85
Figure 5-19. Simplex Dataforth Configuration Example.....	87
Figure 5-20. Thermocouple Wiring to Simplex Dataforth FTM.....	88
Figure 5-21. RTD Wiring to Simplex Dataforth FTM	89
Figure 5-22. Loop powered 4–20 mA Signal Wiring to Simplex Dataforth FTM ..	89
Figure 5-23. Self-powered 4–20 mA Signal Wiring to Simplex Dataforth FTM....	90
Figure 5-24. 0–5 Vdc Signal Wiring to Simplex Dataforth FTM	90
Figure 5-25. Analog Output Signal Wiring to Simplex Dataforth FTM.....	91
Figure 5-26. Dataforth Plug-in Modules	91
Figure 5-27. 34 Channel HDVIM Module	95
Figure 5-28. Simplex System Configuration Example.....	98
Figure 5-29. Wiring Diagram for 34 Ch. HDVIM FTM	99
Figure 5-30. Analog Interface Wiring to 34 Ch. HDVIM Module Inputs	101
Figure 5-31. Analog Interface Wiring to the 34 Ch. HDVIM Module Inputs	101
Figure 5-32. 4–20 mA Interface Wiring to 34 Ch. HDVIM Module RTD Inputs..	101
Figure 5-33. RTD Interface Wiring to the 34 Ch. HDVIM Module RTD Inputs...	101
Figure 5-34. 8 Channel Current Input (4–20 mA) Module.....	104
Figure 5-35. 8 Ch. Current Input (4–20 mA) Module Configuration	104
Figure 5-36. Analog Input Wiring for an 8 Ch. Current Input (0–25 mA) Module	106
Figure 5-37. 8 Ch. Current Input (0–25 mA) Module Block Diagram	107
Figure 5-38. Non-standard 8 Channel Current Input (4–20 mA) Module.....	109
Figure 5-39. Non-Standard 8 Channel Module Configuration	110
Figure 5-40. Analog Input Wiring for a Non-Standard Module	111
Figure 5-41. 8 Channel Voltage Input (0–10 Vdc) Module.....	113
Figure 5-42. 8 Ch. Voltage Input (0–10 Vdc) Module Configuration	114
Figure 5-43. Voltage Input Wiring for an 8 Chnl Voltage Input Module.....	115
Figure 5-44. 8 Ch. Voltage Input (0–10 Vdc) Module Block Diagram	116
Figure 5-45. 8 Channel Current Output (4–20 mA) Module	118
Figure 5-46. 8 Ch. Current Output (4–20 mA) Module Configuration	119
Figure 5-47. Analog Output Wiring for 8 Chnl Output (4–20 mA) Module	120
Figure 5-48. Current Output (4–20 mA) Module Block Diagram	121
Figure 5-49. 8 Channel Current Output (0–1 mA) Module	122
Figure 5-50. 8 Channel Voltage Output (0–5 Vdc) Module	123
Figure 5-51. 8 Ch. Voltage Output (0–5 Vdc) Module Configuration	124
Figure 5-52. Analog Output Wiring for an 8 Chnl Voltage Output Module	125
Figure 5-53. 8 Ch. Voltage Output (0–5 Vdc) Module Block Diagram	126
Figure 5-54. 8 Channel Voltage Output (0–10 Vdc) Module	127
Figure 5-55. 8 Channel TC (Fail Low) Module	128
Figure 5-56. 8 Ch. TC (Fail Low) Module Configuration	129
Figure 5-57. 8 Ch. TC Input (Fail Low) Module Field Wiring.....	130
Figure 5-58. Thermocouple Input Block Diagram.....	131
Figure 5-59. 8 Channel TC (Fail High) Module	133
Figure 5-60. 8 Channel RTD Input Module (10 ohm).....	134
Figure 5-61. 8Ch RTD Module Configuration.....	135

Figure 5-62. 8Ch RTD Input Module Field Wiring	137
Figure 5-63. RTD Input Block Diagram	138
Figure 5-64. 8 Channel RTD Input Module (100 ohm).....	139
Figure 5-65. 8 Channel RTD Input Module (200 ohm).....	141
Figure 5-66. 8 Channel RTD Input Module (500 ohm).....	142
Figure 5-67. 4 Channel MPU/Proximity Module	144
Figure 5-68. 4 Ch. MPU/Proximity Module.....	145
Figure 5-69. MPU and Proximity Probe Interface Wiring	146
Figure 5-70. Digital Speed Sensor Module Block Diagram.....	147
Figure 6-1. Four Channel Actuator Driver Module	149
Figure 6-2. Four Channel Actuator Driver Module Block Diagram.....	150
Figure 6-3. EM/TM Position Control Module	151
Figure 6-4. Position Control Module as used with various Remote Drivers.....	152
Figure 6-5. Position Controller Module Block Diagram	154
Figure 7-2. Service Panel Block Diagram	156
Figure 7-3. Service Panel Outline Dimensions.....	156
Figure 7-4. Service Panel Cutout Dimensions	157
Figure 7-5. Service Panel Optional 19 Inch Mounting Panel	157
Figure 7-6. Ethernet Interface FTM	158
Figure 7-7. Ethernet Interface FTM Outline Drawing	158
Figure 7-8. Kit Configuration (040 CPU)	159
Table 2-1. Off-line Tests.....	13
Table 2-2. Flash Codes	14
Table 2-3. On-Line Tests.....	15
Table 2-4. Test Failure Messages.....	15
Table 2-5. Operation Errors.....	16
Table 2-6. Numbered System Errors.....	16
Table 2-7. System Alarms	17
Table 2-8. System Alarms	18
Table 2-9. Numbered System Alarms	18
Table 3-1. Remote XCVR Module Jumpers (JPR1–4).....	21
Table 3-2. Ethernet Module LED Annunciations	26
Table 3-3. RJ45 Ethernet Pinout	28
Table 4-1. LED Indications of Failure	41
Table 4-2. Discrete Outputs/Relay Module Configuration.....	46
Table 4-3. LED Indications of Failure	51
Table 5-1. LED Indications of Failure	61
Table 5-2. LED Indications of Failure	73
Table 5-3. LED Indications of Failure	83
Table 5-4. Module Accuracy.....	86
Table 5-5. LED Indications of Failure	92
Table 5-6. LED Indications of Failure	102
Table 5-7. Thermocouple Types and ranges	129
Table 5-8. Thermocouple Types and ranges	133
Table 5-9. 4Ch. MPU/Proximity Modules Compatibility with CPU5200	143
Table 6-1. LED Indications of Failure	153

The following are trademarks of Woodward, Inc.:

Woodward

The following are trademarks of their respective companies:

Modbus (Schneider Automation Inc.)

Pentium (Intel Corporation)

Warnings and Notices

Important Definitions



This is the safety alert symbol used to alert you to potential personal injury hazards. Obey all safety messages that follow this symbol to avoid possible injury or death.

- **DANGER** - Indicates a hazardous situation, which if not avoided, will result in death or serious injury.
- **WARNING** - Indicates a hazardous situation, which if not avoided, could result in death or serious injury.
- **CAUTION** - Indicates a hazardous situation, which if not avoided, could result in minor or moderate injury.
- **NOTICE** - Indicates a hazard that could result in property damage only (including damage to the control).
- **IMPORTANT** - Designates an operating tip or maintenance suggestion.



WARNING

Overspeed / Overtemperature / Overpressure

The engine, turbine, or other type of prime mover should be equipped with an overspeed shutdown device to protect against runaway or damage to the prime mover with possible personal injury, loss of life, or property damage.

The overspeed shutdown device must be totally independent of the prime mover control system. An overtemperature or overpressure shutdown device may also be needed for safety, as appropriate.



WARNING

Personal Protective Equipment

The products described in this publication may present risks that could lead to personal injury, loss of life, or property damage. Always wear the appropriate personal protective equipment (PPE) for the job at hand. Equipment that should be considered includes but is not limited to:

- Eye Protection
- Hearing Protection
- Hard Hat
- Gloves
- Safety Boots
- Respirator

Always read the proper Material Safety Data Sheet (MSDS) for any working fluid(s) and comply with recommended safety equipment.



WARNING

Start-up

Be prepared to make an emergency shutdown when starting the engine, turbine, or other type of prime mover, to protect against runaway or overspeed with possible personal injury, loss of life, or property damage.

NOTICE

Battery Charging Device

To prevent damage to a control system that uses an alternator or battery-charging device, make sure the charging device is turned off before disconnecting the battery from the system.

Electrostatic Discharge Awareness

NOTICE

Electrostatic Precautions

Electronic controls contain static-sensitive parts. Observe the following precautions to prevent damage to these parts:

- Discharge body static before handling the control (with power to the control turned off, contact a grounded surface and maintain contact while handling the control).
- Avoid all plastic, vinyl, and Styrofoam (except antistatic versions) around printed circuit boards.
- Do not touch the components or conductors on a printed circuit board with your hands or with conductive devices.

To prevent damage to electronic components caused by improper handling, read and observe the precautions in Woodward manual **82715**, *Guide for Handling and Protection of Electronic Controls, Printed Circuit Boards, and Modules*.

Follow these precautions when working with or near the control.

1. Avoid the build-up of static electricity on your body by not wearing clothing made of synthetic materials. Wear cotton or cotton-blend materials as much as possible because these do not store static electric charges as much as synthetics.
2. Do not remove the printed circuit board (PCB) from the control cabinet unless necessary. If you must remove the PCB from the control cabinet, follow these precautions:
 - Do not touch any part of the PCB except the edges.
 - Do not touch the electrical conductors, the connectors, or the components with conductive devices or with your hands.
 - When replacing a PCB, keep the new PCB in the plastic antistatic protective bag it comes in until you are ready to install it. Immediately after removing the old PCB from the control cabinet, place it in the antistatic protective bag.

Chapter 1.

General Information

Introduction

This manual contains obsolete boards, cards, and CPUs from the MicroNet Simplex and MicroNet Plus Digital Controls, created to serve as a reference volume for customers who are using this equipment in their systems. All safety and compliance information is contained in Volume 1 and Volume 2 of this manual.

WARNING

Refer to Manual 26166, Volumes 1 and 2 for Required Safety Instructions, Special Conditions for Safe Use and Hazardous Location Requirements to insure the control is used in a safe manner in Ordinary, Marine, Hazardous, ATEX and IECEx locations. Volume 1 must be fully understood and complied with for all applications.

NOTICE

The information contained within this volume pertains to modules, which may be active in the field, but are obsolete and no longer supported by Woodward. These modules are not recommended for new systems or designs.

**Obsolete Boards,
Cards and CPUs**

Chapter 2.

CPUs

Introduction

This chapter contains information on CPUs and each section pertains to a different CPU with all of the data from the original manual.

2.1. CPU_040 Module

2.1.1—Module Description



Figure 2-1. 040 CPU Module

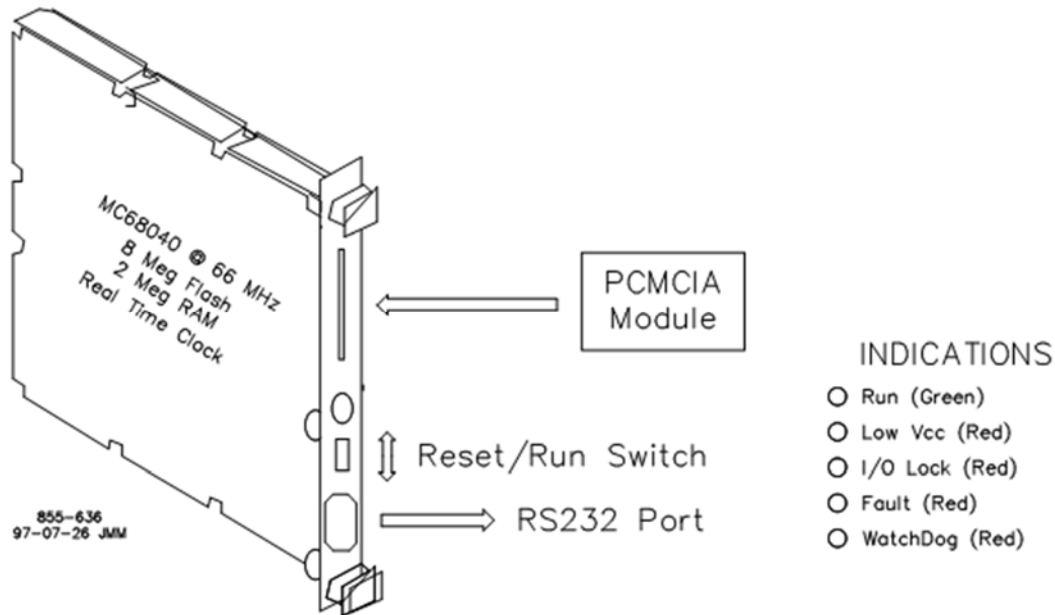

Figure 2-1. CPU Module

IMPORTANT

The information in this chapter on the CPU_040s is for legacy systems that use the old CPU_040 CPUs. Use the CPU_5200 CPUs for all new designs.

Every MicroNet TMR control contains three CPU modules, one located in the second slot of each kernel, just to the right of the kernel power supply.

For CPU module installation and replacement instructions, see the instructions for installing the VME module in Chapter 14, and for replacement in Chapter 15.

The CPU modules run the application program. Figure 5-7 is a block diagram of a CPU module. When the reset switch is toggled to the Run position, the CPU modules will perform diagnostic tests, sync together, and then run the application program.

The CPU has a PCMCIA (Personal Computer Memory Card International Association) slot on its front panel. The PCMCIA slot is used to download application files to the CPU module.

The CPU module contains a battery to power the real time clock when power to the control is off. This battery is not user-replaceable. During normal operation, on-board circuitry keeps the battery charged. Once the battery is fully charged (taking a maximum of three days), the battery will continue to run the clock for a minimum of three months without external power to the control. If power is removed from the CPU module for longer than three months, the real time clock may need to be reset. The resolution of the real time clock is 10 milliseconds.

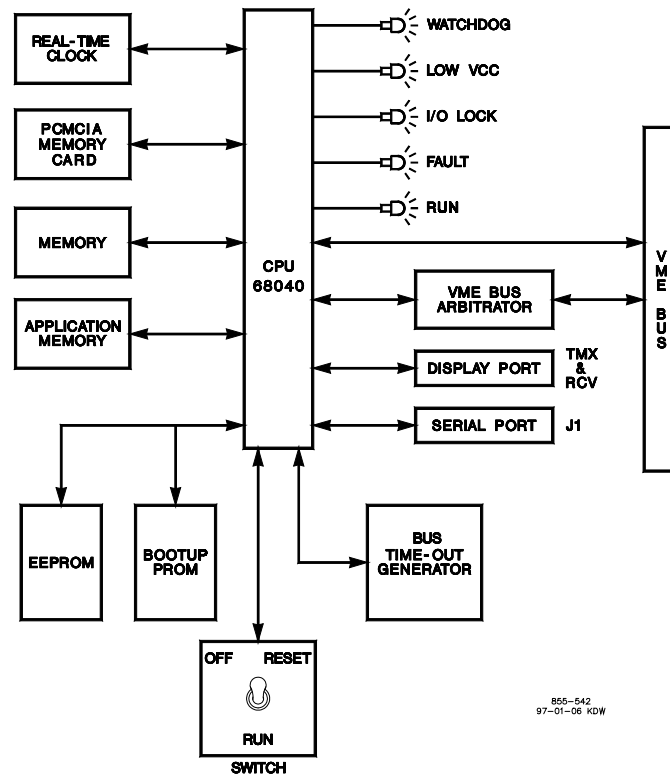

Figure 2-2. CPU Module Block Diagram

2.1.2—RS-232 Serial Port COM1

An RS-232 serial port is located on the front of the CPU module. This port should only be connected to a device with an isolated serial port. Baud rate is selectable from 300 baud to 38.4 Kbaud. Before this port can be used, Woodward kit P/N 8298-096 must be installed. To install this kit, the CPU must have screw posts. Some of Woodward's earlier CPU modules have slide lock posts. These must be sent to Woodward for upgrade before the port may be used. See Chapter 12 for details on how to install this port filter kit. Shielded cable is required when connecting to the CPU module's serial port. Using shielded cable will help ensure the robustness of the serial communications.

This communication port is non-isolated. Shielded cable and a Serial Port Isolator/ Converter is required when using this port to avoid susceptibility to EMI noise and ground loops related to PC connections and typical industrial environments. The following standard options are available:

- RS-232–RS-232 Isolator and Filter
- RS-232–RS-485 Isolator/Converter and Filter
- RS-232–RS-422 Isolator/Converter and Filter

IMPORTANT

A Serial Port Isolator/Converter must be properly installed, grounded, and powered prior to connection with the CPU. Once properly installed, it may be connected to a field device at any time. Alternatively, the isolator may be connected to the field device. However, it must be properly installed, grounded, and powered prior to connection to the CPU.

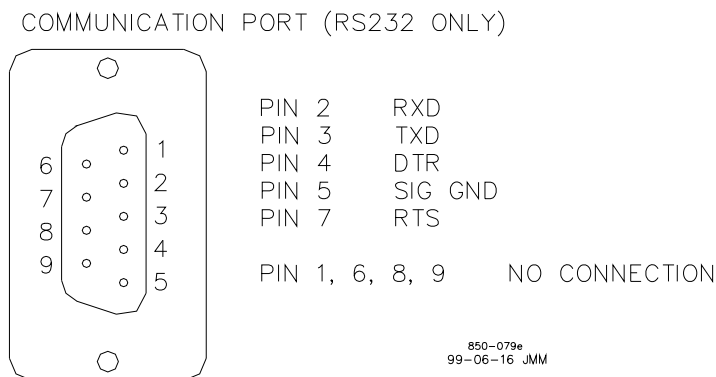

Figure 2-3. 68040 CPU Communications Port

2.1.3—FTM Reference

No FTM is used with this CPU. However, additional installation and application information can be found in Chapter 12.

2.1.4—Troubleshooting and Tuning

The MicroNet Operating System runs both off-line and on-line diagnostics. Diagnostics are run at power-up or when the Reset switch is toggled (off-line), and automatically when operating under application-program control (on-line).

2.1.4.1. 68040 CPU Off-Line Diagnostics

The following table shows the tests run by off-line diagnostics, and the order in which they are run. Off-line diagnostics are started immediately after the Reset has toggled.

Table 2-1. Off-line Tests

TEST	EXPLANATION OF TEST
1. CSR (Control Status Register) Test	The CSR register of the CPU is tested by writing to it, reading from it, and then testing the value read back.
2. Simple DUART (dual universal asynchronous transmitter)	This test checks the DUART counter/timer, and on Channel A of the CPU module, it does a receiver/internal wrap-around test. If the Channel passes the test, the display is initialized, and communication with the VFD (vacuum-fluorescent display) is set up. If the VFD does not respond, the system sets up for a dumb terminal.
3. Local RAM Test	This test checks all of the local RAM installed by performing the following tests: A. Marching One test (writes to a bit location in memory, then reads that location back to verify it his is repeated for every bit-location in memory. B. Write Byte, read word; write word, read byte, etc. C. If memory is less than 512 KB, perform wraparound test (writes past word boundaries). D. Misalign test (accesses memory on a misaligned word boundary).
4. Application RAM Test	This test determines whether the memory for the application is RAM or PROM. If application memory is PROM, no tests are done. If application memory is RAM, the following tests are performed. A. Marching One test. B. Write Byte, read word; write word, read byte, etc. C. If me D. Misalign test.
5. Extensive DUART Test	This test checks both channels of the DUART with: A. Internal wrap-around test

TEST	EXPLANATION OF TEST
	B. Different BAUD rates, data bits, etc.
6. Clock interrupt Test	This test enables the interrupt timer and checks that the interrupts are being generated.
7. Local Bus Timeout Test	This test writes to a location on the Woodward I/O bus with no memory (module) installed and checks that a bus error occurs.
8. VME Bus Timeout Test	This test writes to a location on the VME bus with no module installed, and verifies that a bus error occurs.
9. PROM Write Test	This test makes the CPU think that PROM is installed. It then writes to a location and verifies that the CPU generates a bus error.
10. EEPROM Test	This test uses the last few locations in the EEPROM. It writes to a location, reads the data back, and checks to see if the write was successful. It then repeats the procedure for different locations.
11. FPU (Floating Point)	This test checks the register locations on the Unit) Test co-processor, does some math calculations with known answers, and checks to be sure the answers returned are correct.
12. BOOT	If the self-test has been successful so far, the system checks to see if PROM is installed. If PROM is installed, and if it has a valid application program in it, that program will be executed. If RAM is installed, the system checks the VME bus to see if there is a memory module with a valid application program. If it finds one, it will download it to the CPU RAM and execute it. If there is no application program, the system sets up for a download and requests the operator to download an application program. If PCMCIA module is installed, the CPU will download the application from the PCMCIA module and execute it.

If during diagnostics, a particular test fails, testing stops and a message identifying the cause of the failure will be displayed. Also, the FAILED LED on the CPU module will periodically repeat bursts of flashes; the number of flashes in each burst indicates the test that failed as shown in Table 2-2.

Table 2-2. Flash Codes

FLASHES IN BURST	ERROR DETECTED
1	Start Up test failed
2	Control Status Register test failed
3	DUART test Failed
4	Local RAM test failed
5	Local RAM Misaligned test failed
6	Application RAM test Failed
7	Application RAM Misaligned test failed
8	Clock Interrupt test failed
9	Local Bus Timeout test failed
10	VME Bus Timeout test failed
11	PROM Write test failed
12	EEPROM test failed
13	Floating Point Math Co-processor test failed

2.1.4.2. 68040 CPU On-Line Diagnostics

As soon as the application program starts running, the system will use a small portion of run time to continuously run the following on-line diagnostic tests.

Table 2-3. On-Line Tests

TEST	EXPLANATION OF TEST
1. Local Memory Test	This test gets a location from memory, saves the data from that location, and then writes several different values to that location. It reads each value back, and checks it to be sure it is correct. It then restores the saved original data back to the RAM and repeats the process at another location.
2. Application Memory Test	RAM only: If the memory is RAM, this test gets a location from memory, saves the data from that location, and then writes several different values to that location. It reads each value back, and checks it to be sure it is correct. It then restores the saved original data back to the RAM and repeats the process at another location. UVPRAM, RAM, and Flash: The test then calculates the sumcheck value and compares it to the sumcheck value previously calculated offline and stored in memory.
3. FPU (Floating Point Unit) Test	This test checks the register locations on the co-processor, does some math calculations with known answers, and checks to be sure the answers are returned correct.
4. Task Overview	This test checks the last eight locations in the task that has just completed to make sure that the values that were set up when the task was created have not changed. If they have, it indicates that the task has overflowed its memory, and destroyed memory in another task.

A failure of any one of the on-line tests results in the I/O lock being asserted and display of a message as shown in Table 2-4. The message will be displayed on the Service Panel at the time the error occurs, and it also will go into the Fault Mode Buffer so that it can be displayed in the Fault Mode.

Table 2-4. Test Failure Messages

TEST	MESSAGE ON FAILURE
Local RAM	Local RAM Failed
Application RAM	Application RAM Failed
FPU (Co-processor)	FPU CO-processor Failed
During execution, an operating system task ran out of memory, or its memory was corrupted by a different task	Task overrun

5.2.4.3. 68040 CPU Operation Errors

Certain other errors can occur during system operation. These errors and their associated messages are listed in Tables 2-5 and 2-6.

Table 2-5. Operation Errors

MESSAGE	MEANING
Checksum Error	Local RAM Failed
System Error (#)	Application RAM Failed (ref. Table 5-6)
EEPROM Fault	FPU C0-processor Failed
Math Exception	The FPU (Co-processor) has received an illegal instruction
Rate Group Slip (#)	Rate group # (number) is scheduled to run and it did not complete its previous scheduled run.
EEPROM Initialization Fault	The CPU attempted to program the EEPROMs during system initialization and failed, or the EEPROM was detected bad (EEPROM FAULT). The system is not permitted to run because the EEPROM data is not current.
Exception Error Vector #	An error was detected by the processor. The vector number indicates which exception the 68040 processor took. For an explanation of exceptions, refer to page 8-5 of Motorola Manual M 68040 UM/AD, MC68040 Enhanced 32-bit Microprocessor User's Manual.

Table 2-6. Numbered System Errors

NUMBER OPER.	SYS. FILE	MEANING
1	CREATE	Cannot create task with priority less than one.
2	CREATE	Stack size requested is smaller than the minimum size.
3	NEWPID	The priority is greater than the maximum allowed.
4	NEWPID	The rate group Proctab entry is not free.
5	NEWPID	All the Proctab entries are full.
6	GETMEM	Tried to get a (zero-byte) block of memory.
7	GETMEM	No memory available.
8	GETMEM	Not enough memory available for block size requested.
9	FREEMEM	Returned a (zero-byte) block of memory.
10	FREEMEM	Returned a block of memory outside of heap boundaries.
11	FREEMEM	Unable to return the block of memory
12	NEWSEM	No semaphores available.
13	SUSPEND	Cannot suspend a task that is not current or ready.
14	SCOUNT	The semaphore number is invalid.
15	SCOUNT	The semaphore number passed in is undefined.
16	SCREATE	The initial count is smaller than zero.
17	SIGNAL	The semaphore number is invalid.
18	SIGNAL	The semaphore number passed in is undefined.
19	SIGNALN	The semaphore number is invalid.
20	SIGNALN	The semaphore number passed in is undefined.
21	SIGNALN	Must signal semaphore one or more times.
22	SRESET	The semaphore number is invalid.
23	SRESET	The semaphore number passed in is undefined.
24	RESET	Must set semaphore to zero or larger.
25	WAIT	The semaphore number is invalid.
26	WAIT	The semaphore number passed in is undefined.

When the system detects an error when starting or running an application, the CPU will flash the FAILED LED on the CPU module with two bursts of flashes separated by a medium longer pause. The CPU will re-start flashing the fault codes after a long pause. The number of flashes will match the display message or it can be determined by counting the two groups of short flashes between the medium pause. The number of flashes in each burst indicates the detected failure as shown in Table 2-7.

Table 2-7. System Alarms

FLASHES IN BURST	ERROR DETECTED
5,4	The Applications do not match, CPU_C different.
5,1	The Applications do not match, CPU_B different.
5,2	The Applications do not match, CPU_A different.
5,3	The Applications do not match, ALL different.
5,7	The Ladder Logic Applications do not match.
5,8	The EE (tunable) values do not match, CPU_A different.
5,9	The EE (tunable) values do not match, CPU_B different.
5,10	The EE (tunable) values do not match, CPU_C different...
5,11	The EE (tunable) values do not match, all CPUs different.
5,14	Pickup CPU failed, re-sync process
5,15	Pickup CPU failed, Application does not match running CPUs
5,16	Pickup CPU failed, EE (tunable) values do not match
5,17	Pickup CPU failed, EE (tunable) values do not match
5,19	Pickup CPU failed ,Ladder Logic Applications do not match
5,20	Pickup CPU failed attempt to re-sync with running CPUs
5,21	Pickup CPU failed attempt to re-sync with running CPUs
5,22	Pickup CPU failed attempt to re-sync with running CPUs
5,23	Pickup CPU failed attempt to re-sync with running CPUs
5,24	Pickup CPU failed attempt to re-sync with running CPUs
5,25	Pickup CPU failed attempt to re-sync with running CPUs
6,4	Dual-port RAM error detected (Local Right)
6,5	Dual-port RAM error detected (Local Left)
6,7	Dual-port RAM error detected (Remote Right)
6,8	Dual-port RAM error detected (Remote Left)
6,9	Dual-port RAM error detected (Unknown)
6,14	Vote busted
6,10	Kill CPU called on CPU_A
6,11	Kill CPU called on CPU_B
6,12	Kill CPU called on CPU_C
6,13	Kill CPU called on all CPUs
7,1	Ladder Logic error, flash program failed
7,2	Ladder Logic error, flash program failed
7,4	Ladder Logic error, flash program failed
7,5	Ladder Logic error, flash initialization failed
7,6	Ladder Logic error, flash erase failed
7,8	Ladder Logic error, flash erase failed
7,9	Ladder Logic error, bad flash
7,10	Ladder Logic error, bad flash
7,11	Ladder Logic error, bad flash
7,12	Ladder Logic error,
9,1	Bus error
9,2	Fault detected – Checksum,RG Slip, TaskOver, SystemError, Exception, MathException,
9,3	bus error from Dualport broadcast address
9,4	LL CPU required (needs to have the 2 nd bank of FLASH installed)
9,6	memory fault stack overflow
10,1	insert failed, requested key is greater than NPROC
10,2	insert failed, task is already on a queue
10,3	insert failed, task is already on a queue
10,4	ready failed, task is already READY or CURRENT
10,5	reinsert failed, requested key is greater than NPROC
10,6	reinsert failed, task is already on a queue
88,12	PCMCIA transfer failed

2.1.4.4. CPU_040 Alarms

The possible system alarms are listed in Table 2-8. The numbered system alarms are listed in Table 2-9.

The ALARMS in Tables 2-8 and 2-9 do not automatically display; they are stored by the system and to see them, you must use the OPSYS_FAULTS Mode of the Service Panel.

Table 2-8. System Alarms

MESSAGE	MEANING
SIO n Configuration Fails port x	A configuration error occurred on Port n of SIO x module. n (1-...) = SIO number x (1-4) = port number
SIO n Missing	SIO n module is not installed. n (1-...) = SIO number
SIO n Self-Test Failed	SIO n module failed its self-test. n (1-...) = SIO number
SIO n Initialization Failed	SIO n module failed to initialize. n (1-...) = SIO number
System Alarm # n	A numbered system alarm has occurred. The number of the alarm is n (see Table 20-8, Numbered System Alarms).
Divide by Zero	A divide by zero operation was performed.
Real to Int Conversion Overflow	An Overflow has occurred during a Real-to-integer conversion operation.

Table 2-9. Numbered System Alarms

NUMBER	OPER SYS. FILE	MEANING
1	CLOSE	The device number is invalid.
2	CONTROL	The device number is invalid.
3	GETC	The device number is invalid.
4	INIT	The device number is invalid.
5	OPEN	The device number is invalid.
6	PUTC	The device number is invalid.
7	READ	The device number is invalid.
8	RECVTIM	The time passed inn was less than zero.
9	SEND	The PID number is invalid.
10	SEND	Cannot send message to undefined task.
11	SEND	Process has message pending.
12	SENDF	The PID number is invalid.
13	SENDF	Cannot send message to undefined task.
14	WRITE	The device number is invalid.
15	IOERR	The function is not implemented for this device.
16	TTYCNTL	Baud rate invalid.
17	TTYCNTL	Mode (line/char) invalid.
18	TTYCNTL	Function invalid.
19	TTYREAD	Attempt to read fewer than zero characters.
20	TTYWRITE	Attempt to write fewer than zero characters.
21	ICCCNTL	Function invalid.
22	ICCINIT	Too many SIO modules are defined.

Chapter 3. Communication

3.1. Main Transceiver (XCVR) Module

3.1.1—Module Description

The Main XCVR module is only used with CPU 68040 systems. It allows extension of the VME back plane to the expansion I/O Chassis. The Main XCVR module sends and receives control, data, and address information to and from its associated Remote Transceiver module (see next section of this chapter) in an I/O chassis through a copper transceiver cable. The Main XCVR module is used in the Main Chassis. See Figure 6-6 for a block diagram of the module.

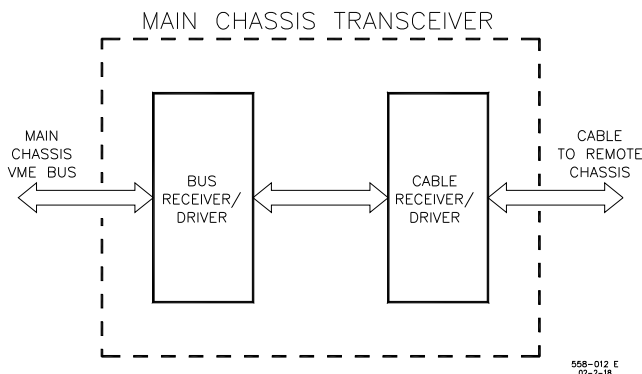

Figure 3-1. Main XCVR Module Block Diagram

3.1.2—Module Specification

- Parallel Interface: High-speed, differential line drivers operating at VME transmission rate
- Cable Interface: 100 pin metal shell Micro-D connector (2 per module)



Figure 3.2. Main XCVR Module

3.1.3—Installation

- The Main XCVR module can be installed in any slot in the Main Chassis.
- No jumpers are used to configure this module.
- This Transceiver module has no switches or LEDs.

3.1.4—Troubleshooting

1. If the Main XCVR module is not functioning or not functioning properly, verify cable connections.
2. If the module is still not functioning properly after verifying the cable connections, replace the cables connecting to module.
3. If the module is still not functioning properly after replacing cables, replace the module.

3.2. Remote Transceiver (XCVR) Module

3.2.1—Module Description

The Remote XCVR module is only used with CPU 68040 systems. The Remote XCVR module receives and sends control, data, and address information via cable to and from its associated Main XCVR module. This module must be used in each Remote I/O Chassis that is connected to the Main Chassis via copper cables.

The Remote XCVR module connects to the VME bus of the chassis. The bus receiver/driver of the Remote Transceiver module interfaces with the VME bus, exchanging control, data, and address information. The chassis decoder determines if this chassis is to be accessed, and if so, it activates the receiver/driver of this chassis' Remote Transceiver module to receive or send information. Figure 6-8 (Chapter 6-1 in Volume 1) is a block diagram of the Remote Transceiver module.

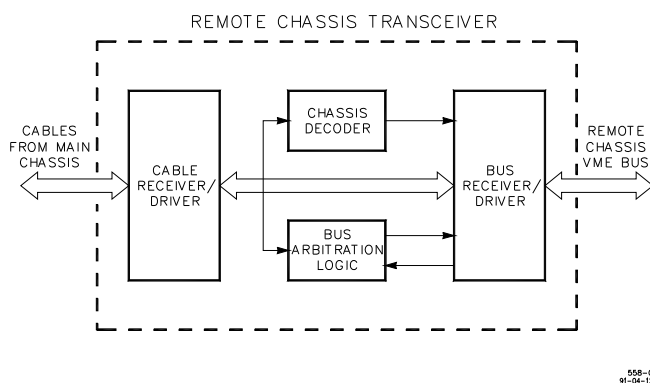

Figure 3-3. Remote XCVR Module Block Diagram

The bus-arbitration logic determines priority of bus-access operations and controls the receiver/driver accordingly.

Table 3-1 shows the jumpers on the Remote XCVR module used to configure the chassis ID.

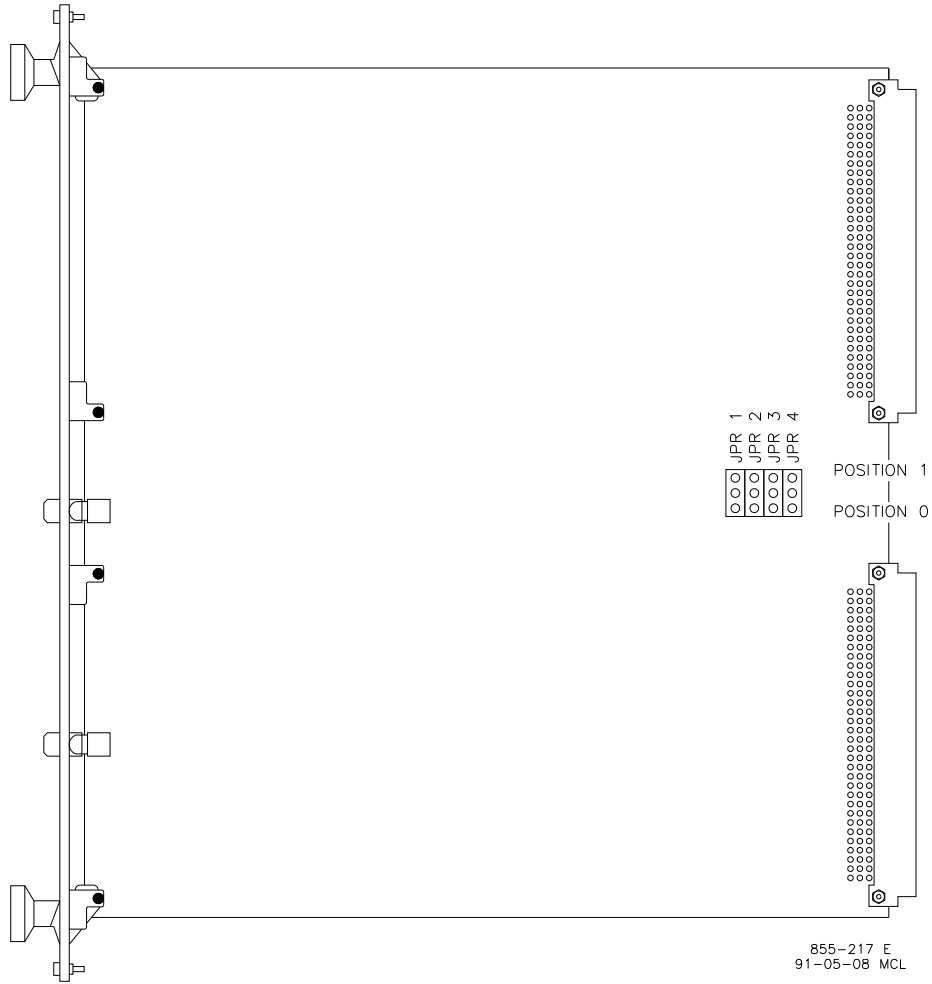

Figure 3-4. Remote XCVR Module Jumpers

Table 3-1. Remote XCVR Module Jumpers (JPR1-4)

	JPR1	JPR2	JPR3	JPR4
CHASSIS 1	0	0	0	1
CHASSIS 2	0	0	1	0
CHASSIS 3	0	0	1	1
CHASSIS 4	0	1	0	0
CHASSIS 5	0	1	0	1
CHASSIS 6	0	1	1	0
CHASSIS 7	0	1	1	1
CHASSIS 8	1	0	0	0
CHASSIS 9	1	0	0	1
CHASSIS 10	1	0	1	0
CHASSIS 11	1	0	1	1
CHASSIS 12	1	1	0	0
CHASSIS 13	1	1	0	1
CHASSIS 14	1	1	1	0
CHASSIS 15	1	1	1	1



Figure 3-5. Remote XCVR Module

3.2.2—Module Specification

Parallel Interface: High-speed, differential line drivers operating at VME transmission rate

Cable Interface: 100 pin metal shell Micro-D connector (2 per module)

3.2.3—Installation

1. The Remote XCVR module has no switches or LEDs.
2. All expansion chassis except for the last one in the chain should use the Remote XCVR module without termination resistors. This module must be installed in Slot 1.
3. The last expansion chassis in the chain should use the Remote XCVR module with termination resistors. This module must be installed in Slot 1.

3.2.4—Troubleshooting

1. If the Remote XCVR module is not functioning or not functioning properly, verify the cable connections.
2. If the module is still not functioning properly after verifying the cable connections, replace the cables connecting to module.
3. If the module is still not functioning properly after replacing cables, replace the module.

3.3. Transceiver Accessories

3.3.1—Description

These accessories are only used with CPU 68040 systems. Each expansion chassis except the last one should have the T-Module mounted next to it. The 3-foot (0.9 m) cables should connect these expansion chassis to the T-Modules. Connections from the Main Chassis, the last Expansion Chassis, and connections between the T-Modules should be made with 10-foot (3 m) cables.

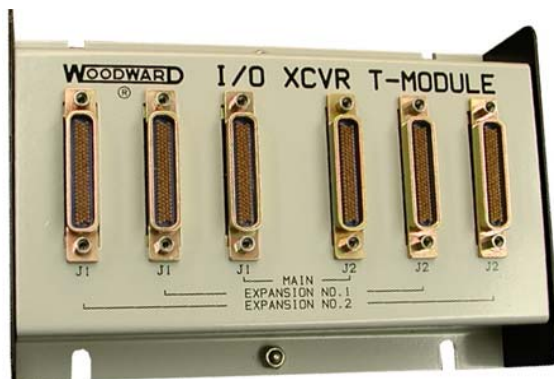

Figure 3-6. T-Module (I/O XCVR-Module)



Figure 3-7. Cables [Available in 3 ft. (0.9 m) and 10 ft. (3 m) lengths]

3.3.2—Module Specification

Parallel Interface:	High-speed, differential line drivers operating at VME transmission rate
Cable Interface:	100 pin metal shell Micro-D connector (2 per module)

3.3.3—Transceiver Accessories Installation (Outline)

IMPORTANT

The Main and Remote Transceiver modules must be connected exactly as shown in the following diagrams (Figures 6-16 and 6-17). The following notes apply on these figures.

Note 1: The Main Transceiver module can be installed in any slot in the Main Chassis.

Note 2: All expansion chassis except for the last one in the chain should use the module without termination resistors. This module must be installed in Slot 1.

Note 3: The last expansion chassis in the chain should use the module with termination resistors. This module must be installed in Slot 1.

Note 4: All expansion chassis except the last one should have the T-Module mounted next to it. The three-foot (0.9 m) cables should connect these expansion chassis to the T-Modules. Connections from the Main Chassis, the last Expansion Chassis, and connections between the T-Modules should be made with ten-foot (3 m) cables.

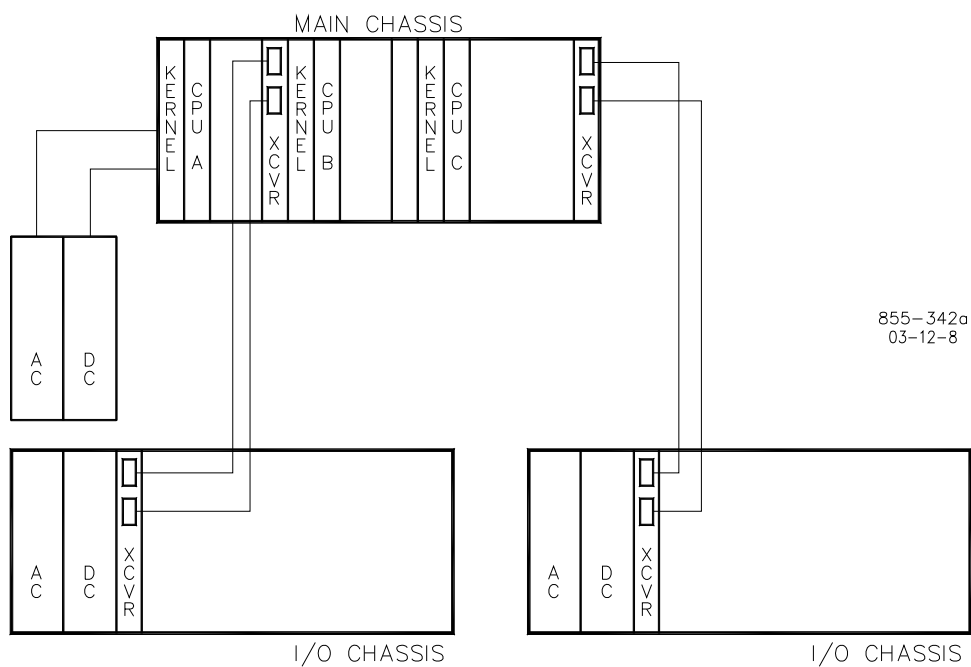

Figure 3-8. Expansion I/O Chassis

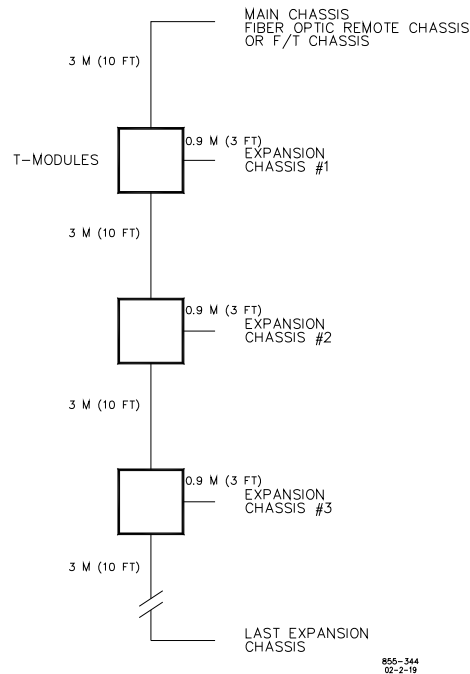

Figure 3-9. Termination

3.4. Ethernet Module

3.4.1—Module Description

The MicroNet Ethernet module is a 32-bit VME bus module, which has been integrated into the MicroNet product family. The module is designed to fully support auto-switching 10/100 Base-TX Ethernet connections, but has been configured to operate at only 10 Mbps for use with legacy products.

The Ethernet module has a VME adapter board attached to allow its use in a MicroNet chassis. However, this module is not “hot swappable” due to signal integrity issues on the VME backplane. When inserted into a powered chassis, the module will interrupt VME bus backplane communications and cause other Woodward modules and expansion racks to shut down.

On power-up, the Ethernet board run a series of self-tests that check the board hardware. After successful completion of the tests, the red FAIL LED will turn OFF. The self-tests may last 10–20 seconds.

IMPORTANT

Due to addressing conflicts with the Pentium CPU, this module can be used only with the Motorola CPU family.



Figure 3-10. Ethernet Module

LED Annunciations

The following LEDs annunciate board failure as well as different functions related to Ethernet communications. When continuous communications are present, the RX and TX LEDs will be ON continuously.

Table 3-2. Ethernet Module LED Annunciations

LEDs	Name	LED Color	Description
<div style="display: flex; flex-wrap: wrap; gap: 10px;"> <div style="text-align: center;">Link <input type="checkbox"/></div> <div style="text-align: center;">Col <input type="checkbox"/></div> <div style="text-align: center;">100 <input type="checkbox"/></div> <div style="text-align: center;">Rx <input type="checkbox"/></div> <div style="text-align: center;">Fail <input type="checkbox"/></div> <div style="text-align: center;">Tx <input type="checkbox"/></div> </div>	LINK	GREEN	Indicates the Ethernet connection is good.
	COL	RED	Indicates a collision on the Ethernet.
	100	GREEN	Indicates the Ethernet connection is functioning at 100 Mbps.
	RX	GREEN	Indicates data is being received.
	TX	GREEN	Indicates data is being received.
	FAIL	RED	Indicates a module reset or self-test failure.

10BaseT Ethernet

A 10BaseT RJ45 Ethernet connector is available for system use. This connection is used for control configuration, data gathering, and networking of multiple controls. In addition, this port may be relied upon for interfacing TCP/IP Distributed I/O devices into the control system.

To ensure signal integrity and robust operation of Ethernet devices, an Ethernet Interface FTM (Field Termination Module) is required when using this port. The FTM's primary function is to implement EMI shielding and cable shield termination of the Ethernet cable. Along with the Ethernet Interface FTM, double-shielded Ethernet cables (SSTP) are required. See the Ethernet Interface FTM section below for more details.

3.4.2—Module Specifications

Ethernet Features

- Industry Standard 6U, VME-32 format
- Network interface conforming to the IEEE 802.3 standard
- Configured for 10BaseT communication support
- Module failure/reset, Link LED, Transmit, Receive, Collision, and 10/100 Mbps LEDs
- Supports Woodward communications such as Modbus, GAP Download, and Tunable Capture/Download.

Electrical Specifications

Voltage:	5.0 Vdc, 5% tolerance
Power:	15.0 W max (13.5 W typical)
Processor:	PowerPC 750, 400 MHz
Memory:	64 MB DRAM, 2 MB boot flash, 32 MB user flash
Bus Interface:	32 bit VME bus
On board I/O:	RJ45 10 Mbps Ethernet port
Hardware Configuration:	VME address #1 or #2 configuration for using 2 modules in a system

3.4.3—Installation

VME Address Configuration

The Ethernet module can be configured for an alternate VME address to support the use of two modules in a MicroNet system. For dual module operation, both the Woodward GAP and the module DIP switch must be configured properly.

IMPORTANT

The DIP switch (S2) is located directly behind the RJ45 Ethernet connector.

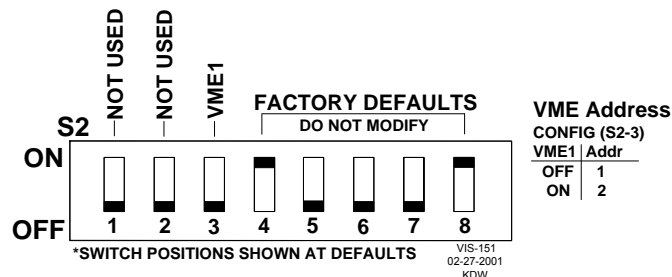
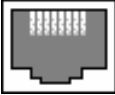

Figure 3-11. VME Address Configuration

Table 3-3. RJ45 Ethernet Pinout

Connector	Signal Mnemonic
RJ45 female 1 8 	Shielded RJ45 female receptacle
1	TX+
2	TX-
3	RX+
4	---
5	---
6	RX-
7	---
8	---
Shield	Chassis GND

3.4.4—FTM Reference

Ethernet Interface FTM

To ensure signal integrity and robust operation of Ethernet devices, an Ethernet Interface FTM (Field Termination Module) is required when interfacing Ethernet devices to the CPU. The FTM's primary function is to implement EMI shielding and cable shield termination of the Ethernet cable. Along with this FTM, double shielded Ethernet cables (SSTP) are required.

Please see Chapter 13 for the Ethernet Interface FTM specifications and wiring information.

3.4.5—Ethernet Module System Requirements

- The Ethernet module is only for use with the Motorola x040/060 CPUs and cannot be used with the Pentium CPU.
- System wiring requires using the Ethernet Interface FTM.
- System wiring requires using shielded RJ45 Ethernet cables (for part numbers, see Appendix A):
 - Double shielded Cat-5 Ethernet cable (SSTP), 1.5 ft. (457 mm)
 - Double shielded Cat-5 Ethernet cable (SSTP), 3 ft. (914 mm)
 - Double shielded Cat-5 Ethernet cable (SSTP), 7 ft. (2.1 m)
 - Double shielded Cat-5 Ethernet cable (SSTP), 10 ft. (3.0 m)
 - Double shielded Cat-5 Ethernet cable (SSTP), 14 ft. (4.3 m)
 - Double shielded Cat-5 Ethernet cable (SSTP), 25 ft. (7.6 m)
 - Double shielded Cat-5 Ethernet cable (SSTP), 50 ft. (15 m)
 - Double shielded Cat-5 Ethernet cable (SSTP), 100 ft. (30 m)

3.4.6—Troubleshooting

1. If the Ethernet module is not functioning or not functioning properly, verify the cable connections.
2. If the module is still not functioning properly after verifying the cable connections, replace the cables connecting to module.
3. If the module is still not functioning properly after replacing cables, replace the module.

Chapter 4.

Discrete I/O Modules

4.1. 24/12 TMR Discrete I/O Module

Each 24/12 TMR Discrete I/O module (TMR High Density Discrete module) contains circuitry for twenty-four (24) discrete inputs and twelve (12) TMR discrete outputs, and provides latent fault detection for each relay output. Each discrete input may be 24 V, or 125 Vdc. Each relay output provides the option of using a normally open contact, or a normally closed contact.

4.1.1—Physical Description

The modules slide into card guides in the control's chassis and plug into the motherboard. The modules are held in place by two screws, one at the top and one at the bottom of the front panel. Also at the top and bottom of the module are two handles which, when toggled (pushed outward), move the modules out just far enough for the boards to disengage the motherboard connectors.



Figure 4-1. 24/12 TMR Discrete I/O Module

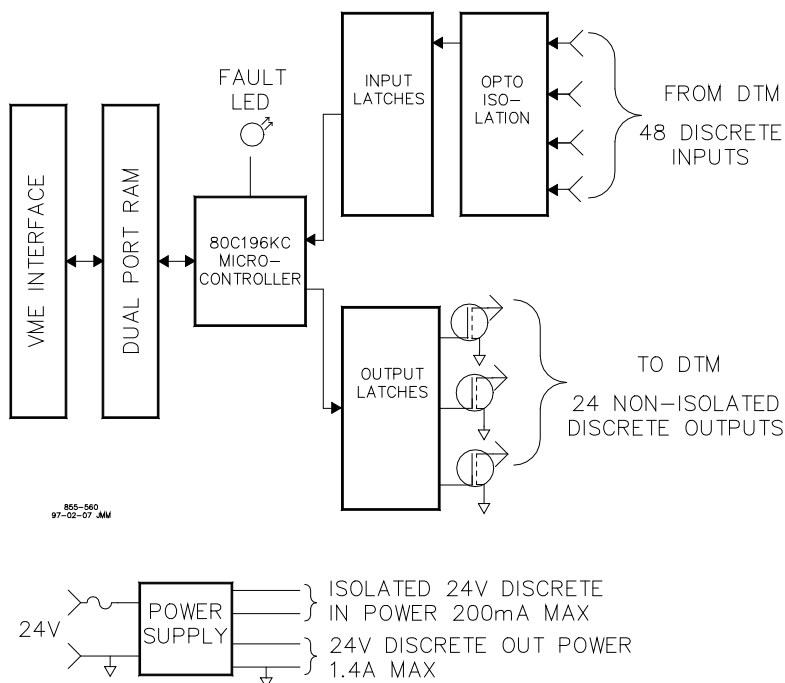

Figure 4-2. 24/12 TMR Discrete I/O Module Block Diagram

4.1.2—Specifications

4.1.2.1. Discrete Inputs

Number of channels:	24
Update time:	5 ms
Input type:	Optically isolated discrete input
24 V Input thresholds:	<8 Vdc = "OFF", at .7 mA >16 Vdc = "ON", at 1.2 mA
125 V Input thresholds:	< 24 Vdc = "OFF", at .7 mA >55 Vdc = « ON », at 4 mA
Input current:	3.5 mA @ 24 Vdc; 8 mA @ 125 Vdc
External input voltage:	18-32 Vdc (LVD and UL) or 100-150 Vdc (UL)
Isolation voltage:	500 Vdc to earth ground, 1000 Vdc to control common
Time stamping:	1 ms resolution
Isolated 24 Vdc contact supply:	400 mA maximum

4.1.2.2. Discrete Outputs

Number of channels:	12
Update time:	5 ms
Relay type:	Dust-tight, magnetic blow-out
Coil rating:	80 mA @ 24 Vdc, suppressor located on circuit board
Minimum load:	50 mA @ 125 Vdc
Relay response time:	15 ms (operate and release)
Relay life expectancy:	50,000 operations @ rated load
Replaceability:	Relays are socket mounted and retained by a hold down spring

Contact ratings:

- 5.0 A @ 240 Vac, 50/60 Hz (resistive) (meets UL ratings only)
- 3.0 A @ 240 Vac, 50/60 Hz (inductive) (meets UL ratings only)
- 10.0 A @ 120 Vac, 50/60 Hz (resistive) (meets UL ratings only)
- 6.0 A @ 120 Vac, 50/60 Hz (inductive) (meets UL ratings only)
- 600 watt @ 120 Vac, 50/60 Hz (lamp) (meets UL ratings only)
- 3.0 A @ 150 Vdc (resistive) (meets UL ratings only)
- 1.2 A @ 150 Vdc (inductive) (meets UL ratings only)
- 10.0 A @ 28 Vdc (resistive) (meets LVD and UL ratings)
- 3.0 A @ 28 Vdc (inductive) (meets LVD and UL ratings)

4.1.3—24/12 TMR Discrete I/O Module and Associated Components

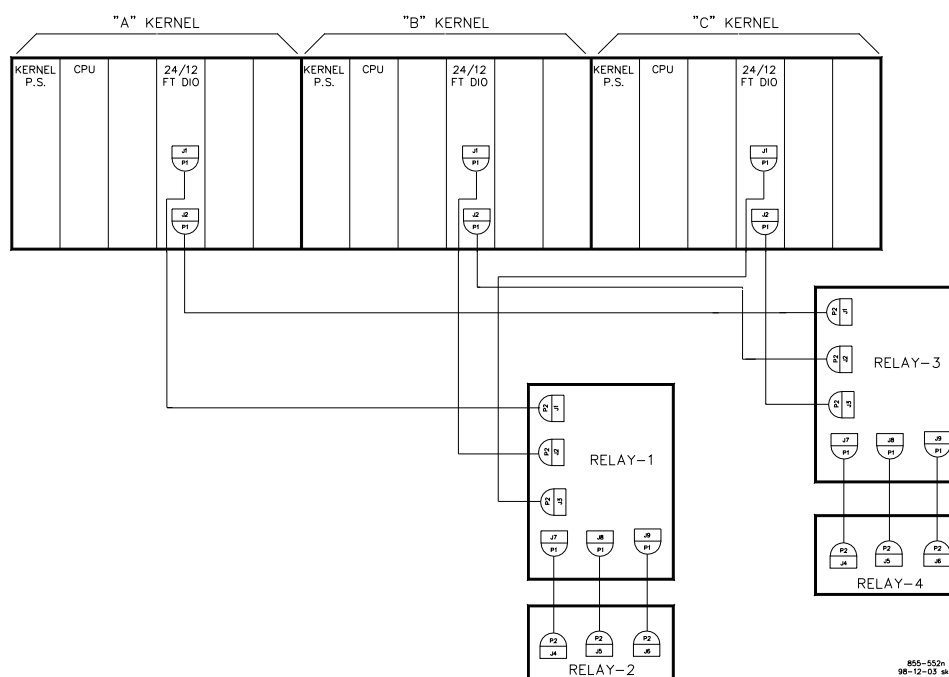

Figure 4-3. Example TMR System Configuration

In a TMR system, each 24/12 TMR Discrete I/O module is connected through two high-density 62 conductor discrete cables to four FT Relay/Discrete Input modules. All of the I/O on 24/12 TMR Discrete I/O module is accessible on the relay modules. See Figure 7-14 for an example.

4.1.4—24/12 TMR Discrete I/O Module Operation

This module includes no potentiometers and requires no calibration. A 24/12 TMR Discrete I/O module may be replaced with another module of the same part number without any adjustment.

4.1.4.1—Field Wiring

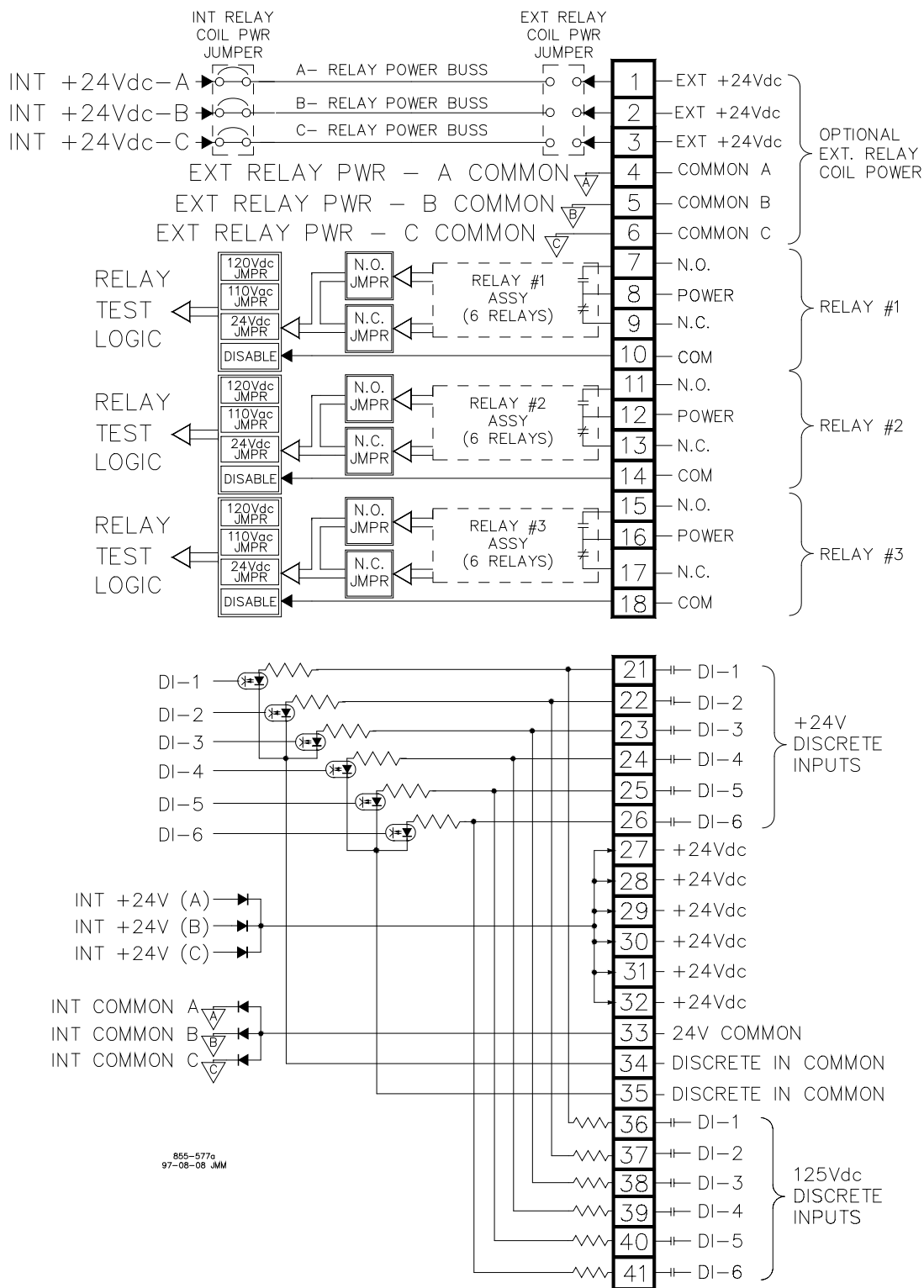

Figure 4-4. Wiring Diagram for a FT Relay/Discrete Input Module

4.1.4.2—Discrete Inputs

The 24/12 TMR Discrete I/O Discrete module accepts 24 discrete inputs. Each of the control's four FT Relay/Discrete Input modules accepts six contact inputs. Contact wetting voltage can be supplied by the control or from an external source. 24 Vdc contact wetting voltage is available on each relay module. Optionally, an external 18-32 Vdc power source or an external 100–150 Vdc power source can be used to source the voltage. Because all discrete inputs are fully isolated, a common reference point must be established between the inputs and the contact power source. If the 24 Vdc internal power source is used for contact wetting, jumpers are required between relay module terminals 33, 34, and 35. If an external power source is used for contact wetting, the external source's common must be connected to the relay module's discrete input commons (terminals 34 and 35).

The inputs have components, which establish a voltage threshold and a current threshold, to prevent a closed indication due to the leakage current of most solid-state relays. The discrete inputs also have time stamping on a change of state, with one millisecond resolution.

Figures 7-18 and 7-19 illustrate the different discrete input wiring configurations based on the input voltage.

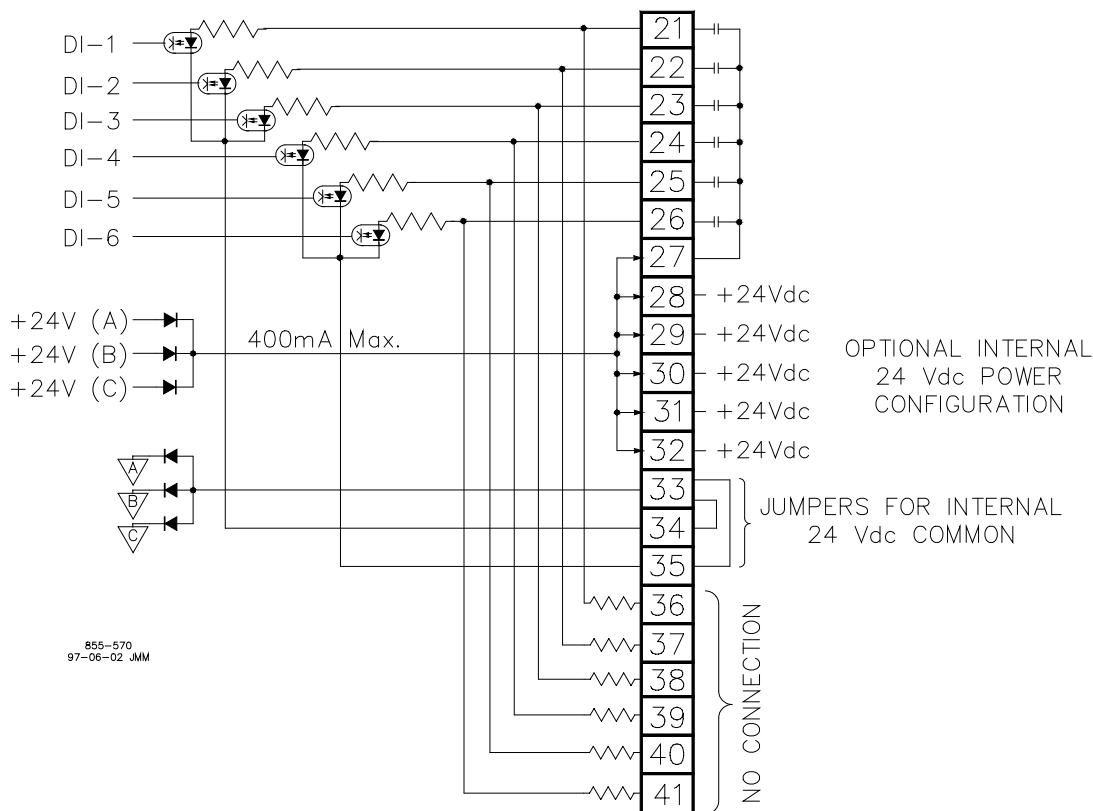

Figure 4-5. Optional Internal 24 Vdc Contact Wetting Configuration

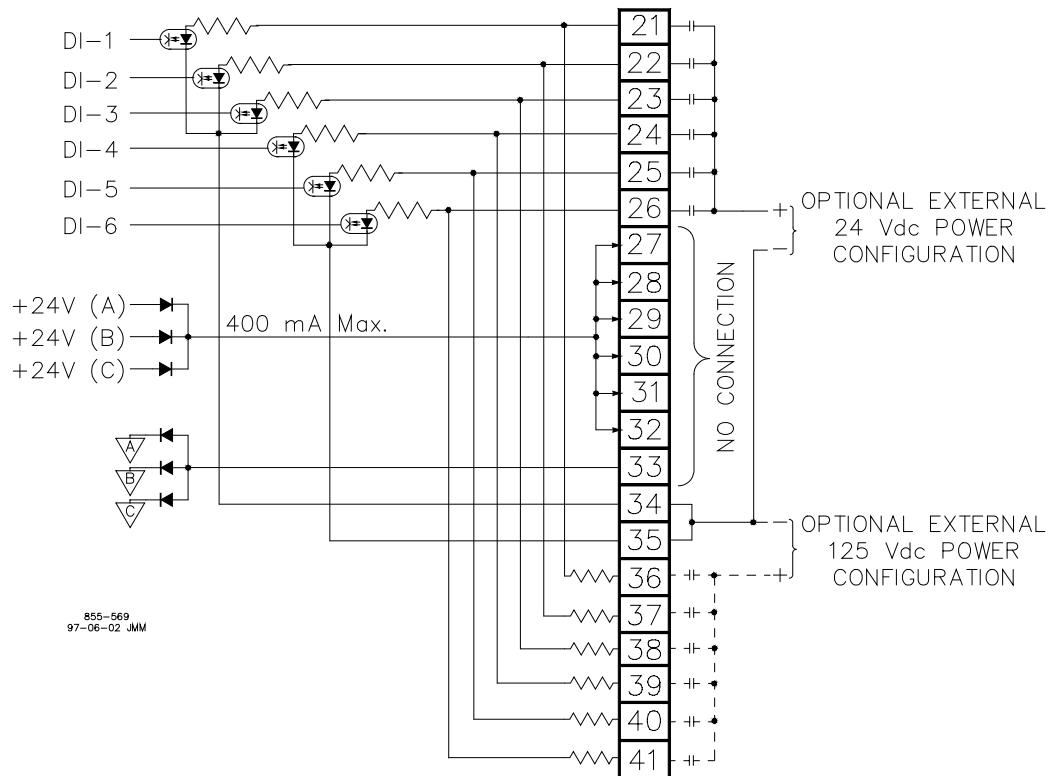

Figure 4-6. Optional External 24/125 Vdc Contact Wetting Configuration

Configuration Notes

IMPORTANT

If there is 125 Vdc on the FT Relay/Discrete Input module terminal blocks, there will be 125 Vdc on the relay module sub D connectors and on the cable when it is connected to the relay module. For this reason, any power should be removed from the relay module terminal blocks, if possible, before installing the 24/12 TMR Discrete I/O module or the relay module.

Refer to Figures 7-18 and 7-19 for contact input wiring.

- All contact inputs accept dry contacts.
- The internal 24 Vdc power source, an external 18-36 Vdc (UL and LVD) power source, or an external 100–150 Vdc (UL only) power source can be used for circuit wetting.
- If the 24 Vdc internal power source is used, jumpers are required between FT Relay/Discrete Input module terminals 33 and 34, and terminals 33 and 35.
- If an external power source is used for contact wetting, the external source's common must be connected to the relay module's discrete input commons (terminals 34 and 35). Power for sensors and contacts must be supplied by the control's power supplies, or the external power supply must be Class II at 30 Vdc or less and outputs must be fused with appropriately sized fuses (a maximum current rating of $100 \div V$, where V is the supply's rated voltage or 5 A, whichever is less).
- Verify that the correct discrete input terminals are used, for low or high voltage inputs.

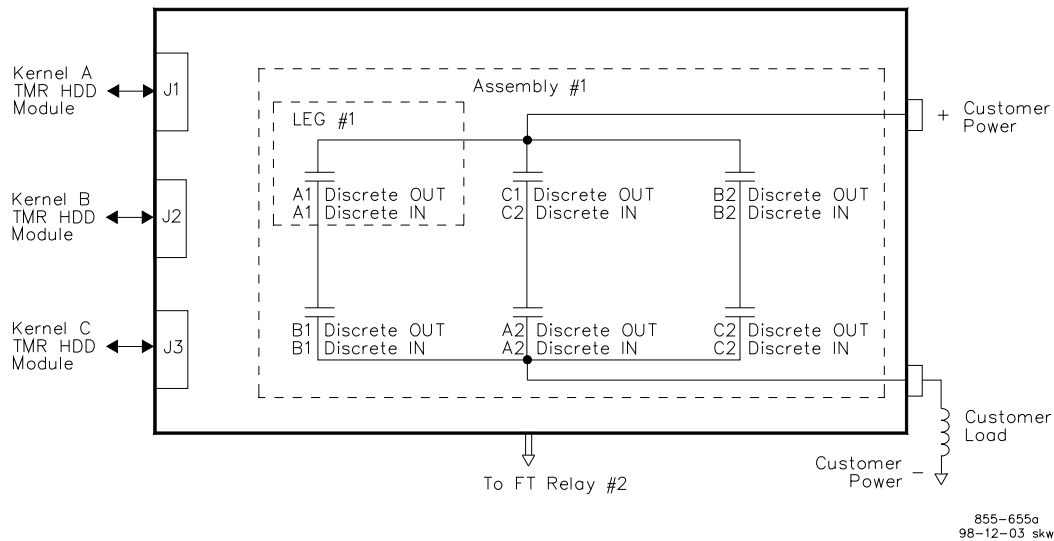

Figure 4-7. TMR Discrete Output

4.1.4.4—Latent Fault Detection

It is important to detect latent faults in a fault tolerant system, because although a single fault may go undetected, if another fault occurs it could cause a shutdown.

Discrete outputs can be configured to use latent fault detection to identify relay failures without affecting a relay output's state. Six individual relays make up one relay output. When a relay output is closed, the contacts of all six relays are closed. Because of the series-parallel configuration of the relays, the failure of any two individual relays will not cause the output to open. The individual relays are periodically opened and reclosed in pairs to ensure that they are in the correct state and that they change state.

When a relay output is open, the contacts of all six relays are open. Because of the series-parallel configuration of the relays, the failure of any one relay will not cause the output to close. The individual relays are periodically closed and reopened one by one to ensure that they change state.

Readback circuitry allows the state of each relay contact to be detected. Any failures are annunciated, and further testing is disabled without affecting the state of the relay output contact or control operation.

Latent fault detection is not appropriate for all applications or circuits. The control's latent fault detection logic can only work with circuits using voltages between 18-32 Vdc, 100-150 Vdc, or 88-132 Vac. For latent fault detection to work, a small leakage current is passed through the circuit's load. Depending on the size of the load, the leakage current may be enough to cause a load to be on or active when a relay contact is open. In this case, the individual relay's latent fault detection logic may be disabled, eliminating the leakage current.

With latent fault detection, when a relay contact is closed, no difference in operation is experienced; the relay output appears as a closed contact. However, when a relay contact is open, it appears to the interfaced circuit as a large resistor instead of an open contact. A small amount of current is leaked to the load, resulting in a developed voltage across the load. In most cases, this has no bearing on the circuitry, because only a small amount of voltage is developed across its load. However, when a relay output is used with a very high resistance load (low current load), enough voltage may be developed across the load to prevent it from de-energizing.

Verifying That Latent Fault Detection Can Be Used With a Relay Output

1. Verify that the circuit the relay output is used with has a voltage level of 18-32 Vdc, 100–150 Vdc, or 88-132 Vac.
2. Use graph, which corresponds to the circuit's voltage level to determine if the voltage developed across the load (due to the leakage current) is lower than the load's dropout voltage level.
 - Acquire the resistance of the load (relay, motor, solenoid, etc.) to be driven by the relay.
 - Acquire the load's minimum dropout voltage.
 - From the bottom of the graph, follow the line corresponding to the load's resistance up to the point at which it intersects the circuit power line. At this point, the corresponding voltage level (on the left of the graph) is the level of voltage that will be developed across the load due to leakage current.

If circuit voltage is acceptable, and the developed load voltage (from the graph) is less than the load's dropout voltage, latent fault detection can be used with the circuit.

If the developed load voltage is greater than the load's dropout voltage, it is recommended that latent fault detection be disabled or that a resistor be connected in parallel (shunt) with the load. A correctly sized resistor connected in parallel with the circuit load will decrease the developed load voltage below the load's dropout voltage level. Using the corresponding latent fault detection graph and the load's minimum dropout voltage, perform the above procedure in reverse (see Step #2) to determine an acceptable shunt resistance. When selecting a shunt resistor, also verify that its voltage and wattage ratings meet that of the circuit.

Latent Fault Detection Verification Example

(Figure 7-20)

Circuit power = 110 Vac; load resistance = 200 ohms; load drop-out voltage = 25 Vac

Using the graph below, the intersection point between the 200-ohm load resistance line and the 110 Vac line was found. From this intersection point it was determined that the voltage developed across the load due to leakage current when the relay is open, is approximately 7.5 Vac. This voltage level is lower than the load's 25 Vac dropout voltage, so latent fault detection can be used.

If, however, the load resistance were 1200 ohms, the intersection would be approximately 29.5 Vac, too high for latent fault detection. By following the graph along the allowable dropout voltage, 25 Vac, it can be determined that a total load resistance of 900 Ohms or less is needed. By placing a properly rated 3600 ohm resistor in shunt with the load, ($1200 \text{ ohms} // 3600 \text{ ohms} = 900 \text{ ohms}$) latent fault detection can be used.

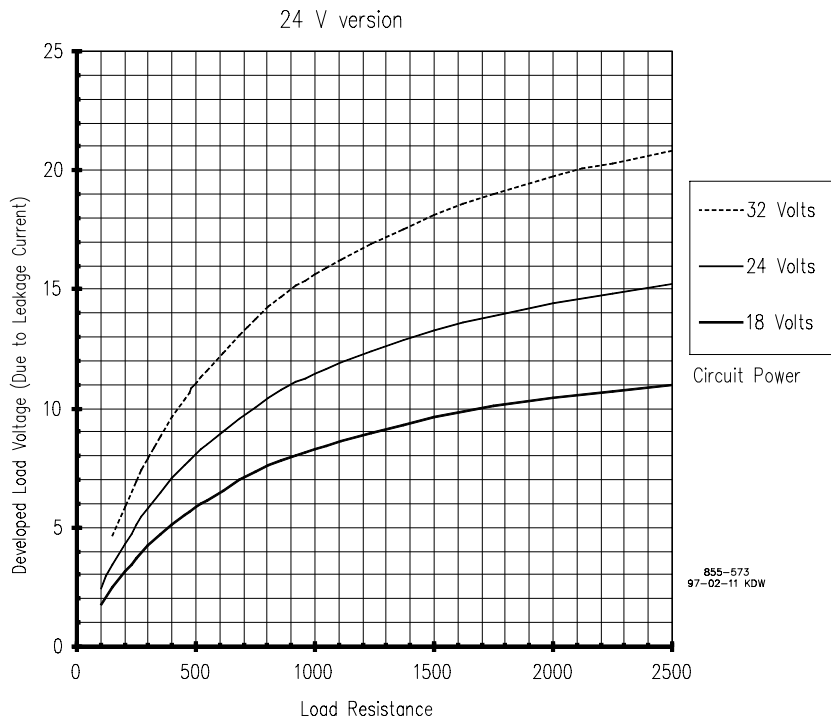

Figure 4-8. Latent Fault Detection Verification Graph–18-32 Vdc Circuitry

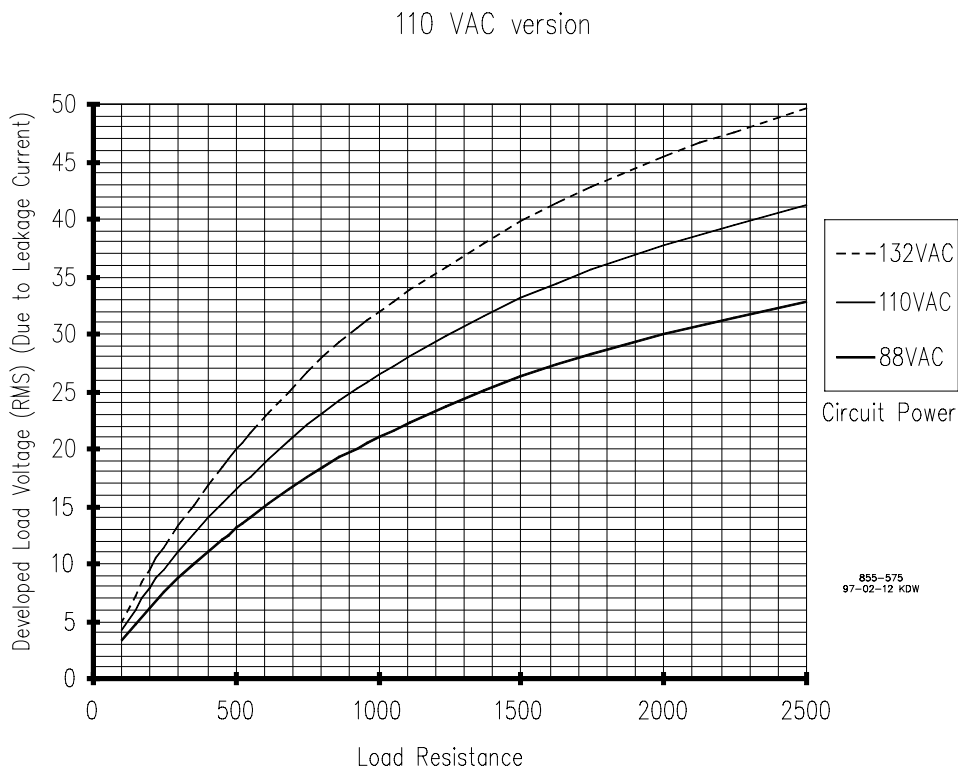

Figure 4-9. Latent Fault Detection Verification Graph–18-132 Vac Circuitry

125 VDC version

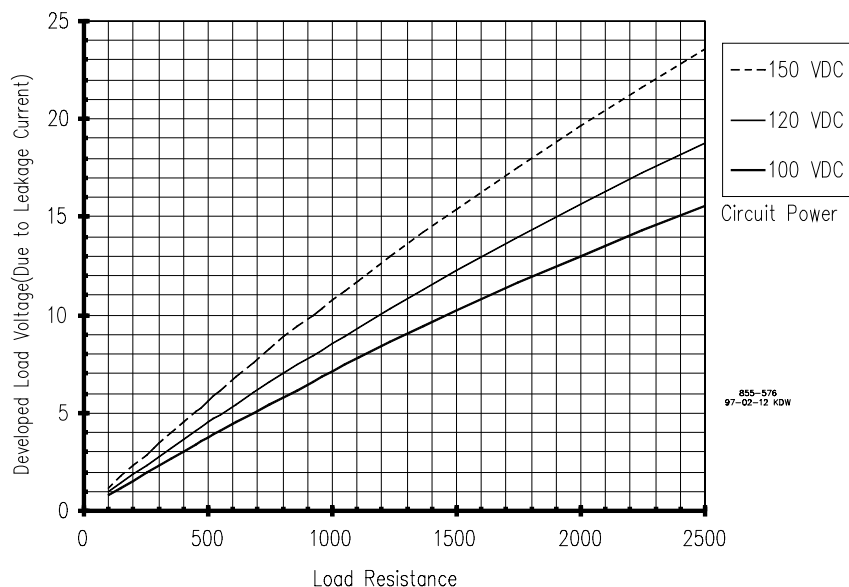

Figure 4-10. Latent Fault Detection Verification Graph—100–150 Vdc Circuitry

4.1.4.5—Relay Jumper Configurations

Relay coil power should be supplied by the control, because this supply is fault tolerant. Jumper banks (four jumpers in one package) are provided on each relay module to allow field selection of internal or external relay coil power. See Figure 14-12. If it is necessary to supply external relay coil power, the relay coil power jumper bank must be moved from its defaulted INT. position to the EXT. position.

To retain circuit integrity if an external power supply is used for relay coil power, the external power supply must be an isolated 24 Vdc source with +5% regulation. It is recommended that a start-up routine be utilized to remove the source during system power-up and power-down. This routine will guarantee that no relay is inadvertently energized due to system power-up surges. (By using the relay module's internal relay coil power this start-up routine is automatically performed.)

Each relay output has two banks of jumpers. One jumper-bank (a set of nine jumpers) is used to match the latent fault detection circuit with the circuit voltage to which it is being interfaced. The second jumper bank (a set of four jumpers) is used to select which set of relay contacts (N.O. or N.C.) is tested by the latent fault detection logic. During operation, only one set of relay contacts (normally open or normally closed) can be tested. The set of relay contacts tested should be same set of relay contacts used by the load. Refer to [Figure 14-12 and 14-13]. Latent fault detection circuitry can be jumper configured to be compatible with the following circuit voltages:

- 18-32 Vdc circuit power
- 88-132 Vac circuit power
- 100–150 Vdc circuit power

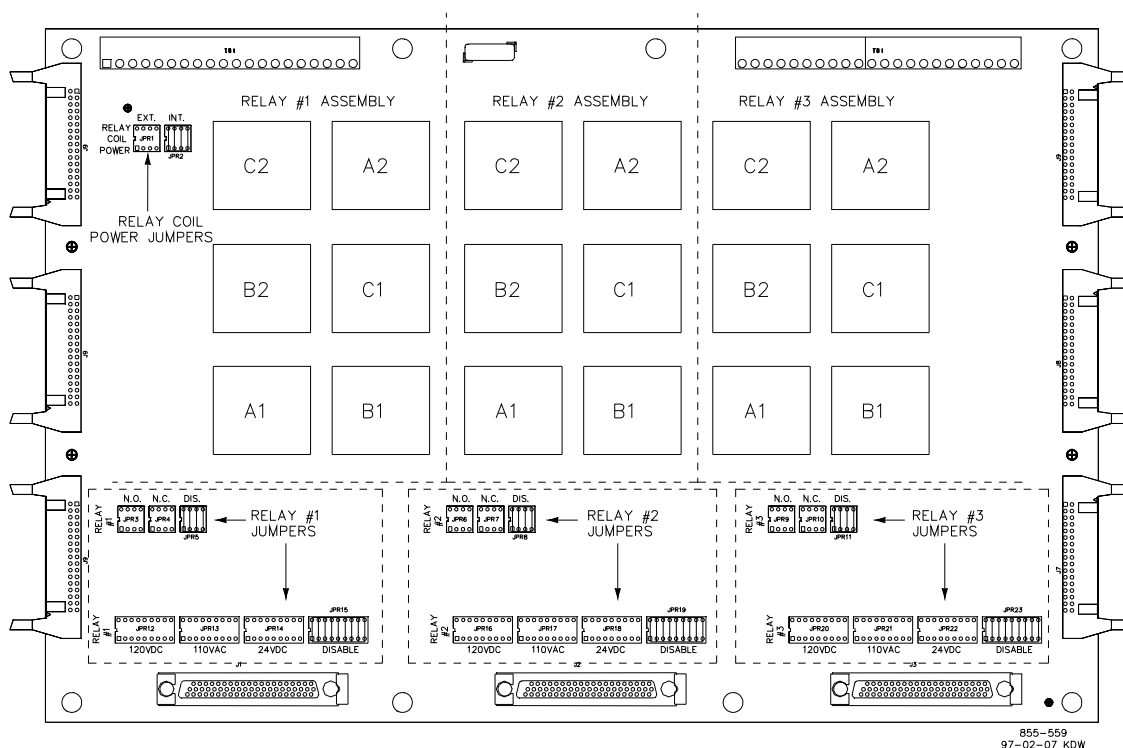

Figure 4-11. Jumper and Relay Location Diagram

After all jumper-banks have been correctly positioned, mark the placement of each jumper-bank on the FT Relay/Discrete Input module cover labels. See the figure below.

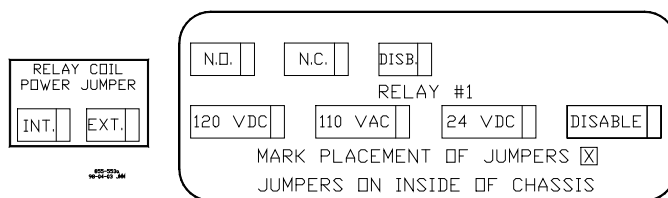

Figure 4-12. FT Relay/Discrete Input Module Labels

Configuration Notes

!
WARNING

HIGH VOLTAGE—If there is 125 Vdc on the FT Relay/Discrete Input module terminal blocks, there will be 125 Vdc on the relay module sub D connectors and on the cable when it is connected to the relay module. For this reason, any power should be removed from the relay module terminal blocks, if possible, before installing the 24/12 TMR Discrete I/O module or the relay module.

- Refer to Figure 7-24 for relay output wiring.
- Verify that each set of relay contacts meets the power requirements of the circuit with which it is being used. Interposing relays are required in cases where the interfaced circuit demands relay contacts with a higher power rating. If interposing relays or other inductive loads are required, it is recommended that interposing relays with surge (inductive kickback) protection be used. Improper connection could cause equipment damage.

- Verify that system power is off before removing or installing any relay module jumper. Use ESD precautions when removing and installing relay module jumper-banks.
- Select internal or external relay coil power. If the control’s internal power is used, verify that the relay module’s “Relay Coil Power Jumper” bank is in the INT. position. If external relay coil power is supplied, move the relay module’s “Relay Coil Power Jumper” bank to the EXT. position and verify that the external source is fully isolated. (Mark the module’s label to indicate jumper position.)
- Verify that latent fault detection can be used with each relay output.
- If latent fault detection cannot be used with the relay output, verify that the relay’s latent fault detection jumper-banks are in their disabled positions. (Mark the module’s label to indicate jumper position.) Alternatively, an external resistor can be wired in parallel with the load to allow latent fault detection to be used with the relay output. In this case, it is the customer’s responsibility to calculate the required resistor ratings and install the resistor.
- If latent fault detection can be used with the relay output, move the relay’s latent fault detection jumper-bank to the correct position for the circuit power. Also, select which set of relay contacts (N.O. or N.C.) are to be tested by the latent fault detection logic. (Mark the module’s labels to indicate jumper positions.)

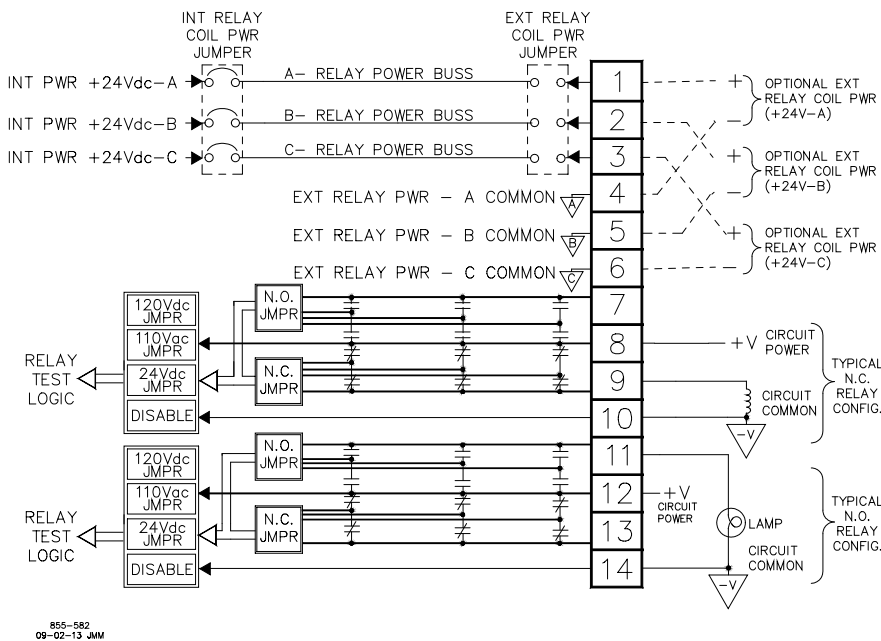

Figure 4-13. Example Relay Output Wiring Diagram

4.1.4.6—Fault Detection (Module Hardware)

Each 24/12 TMR Discrete I/O module has a red Fault LED that is turned on when the system is reset. During initialization of a 24/12 TMR Discrete I/O module, which occurs after every CPU reset, the CPU turns the Fault LED on. The CPU then tests each 24/12 TMR Discrete I/O module using diagnostic routines built into the software. If the diagnostic test is not passed, the LED remains on or blinks. If the test is successful, the LED goes off. If the Fault LED on a 24/12 TMR Discrete I/O module is illuminated after the diagnostics and initialization have been run, the module may be faulty or may be located in the wrong slot.

Table 4-1. LED Indications of Failure

Number of LED Flashes	Failure
2	Micro-controller internal RAM test failure
3	External RAM high and low byte test failure
4	External RAM low byte failure
5	External RAM high byte failure
6	EEPROM failure
7	Software not running
8	System monitor fault
9	MFT pulses missing

Fault Detection (I/O)

In addition to detecting 24/12 TMR Discrete I/O module hardware faults, the application software may detect I/O faults.

Discrete Input Faults

The application software can detect faults by comparing the inputs from the three kernels.

Discrete Output Faults

The module monitors relay coil voltage and contact states. The contacts change state periodically to allow latent fault detection. The application determines the course of action in the event of a fault.

Microcontroller Faults

The system monitors a software watchdog, a hardware watchdog, and a software watchdog on the VME bus communications. All outputs are shut down in the event of a microcontroller fault.

4.1.4.7—24/12 TMR Discrete I/O Module Troubleshooting Guide

If during normal control operation all of a chassis' 24/12 TMR Discrete I/O modules have Fault LEDs on, check the chassis' CPU module for a failure. If during normal control operation, only the 24/12 TMR Discrete I/O module's Fault LED is on or flashing, insures that it is installed in the correct slot. If it is, then replace that 24/12 TMR Discrete I/O module. See instructions for module replacement in Chapter 15, Installation and Service. When a 24/12 TMR Discrete I/O module fault is detected, its outputs should be disabled or de-energized.

Discrete Inputs

If a discrete input is not functioning properly, verify the following:

- Measure the input voltage on the terminal block. It should be in the range of 18-32 Vdc for the low voltage input terminal blocks, or 100–150 Vdc for the high voltage terminal blocks.
- Check the wiring. If the inputs are reading open, look for a loose connection on the terminal blocks, disconnected or misconnected cables, or a missing jumper on the terminal block.
- Check the software configuration to ensure that the input is configured properly.
- If the other channels on the 24/12 TMR Discrete I/O module are also not working, check the fuse on the 24/12 TMR Discrete I/O module. See instructions for module replacement in Chapter 15, Installation and Service. This fuse is visible and can be changed through the bottom of the module. If this fuse is blown, fix the wiring problem and replace the fuse with another fuse of the same type and rating.

After verifying all of the above, remove the 24/12 TMR Discrete I/O module and exchange the J1 and J2 cables. See instructions for replacing the module in Chapter 15, Installation and Service. If the problem moves to a different channel, replace the cable. If not, exchange the cables at the FT Relay/Discrete Input modules so J1 is driving J2 and vice versa. If the problem moves to a different input, replace the 24/12 TMR Discrete I/O module. If the fault remains with the same input, replace the FT Relay/Discrete

Input module. See instructions for replacing the FT Relay/Discrete Input modules in Chapter 15, Installation and Service.

Discrete Outputs

If a discrete output is not functioning properly, verify the following:

- Check the wiring for a loose connection on the terminal blocks and disconnected or misconnected cables.
- Verify that the current through the relay contact does not exceed the contact rating.
- Make sure that if latent fault detection is being used, the trickle current through the relay is insufficient to energize the relay load. See Figures 15-8 through 15-10.
- If the other output channels on the 24/12 TMR Discrete I/O module are also not working, check the fuse on the 24/12 TMR Discrete I/O module. See instructions for module replacement in Chapter 15, Installation, and Service. This fuse is visible and can be changed through the bottom of the module. If this fuse is blown, fix the wiring problem and replace the fuse with another fuse of the same type and rating.
- Check the software configuration to ensure that the output is configured properly.

After verifying all of the above, remove the 24/12 TMR Discrete I/O module and exchange the J1 and J2 cables. See instructions for replacing the module in Chapter 15, Installation, and Service. If the problem moves to a different channel, replace the cable. If not, exchange the cables at the FT Relay/Discrete Input modules so J1 is driving J2 and vice versa. See instructions for replacing the module in Chapter 15, Installation and Service. If the problem moves to a different relay, replace the 24/12 TMR Discrete I/O module or the relay. See instructions for replacing the FT Relay/Discrete Input modules and relays in Chapter 15, Installation and Service. If the fault remains with the same relay, replace the relay or the FT Relay/Discrete Input module.

4.2. 48/24 Discrete Combo Module

4.2.1—Module Description

A 48/24 Discrete Combo module contains circuitry for forty-eight discrete inputs and twenty-four discrete outputs. These modules have no potentiometers and require no calibration. A module may be replaced with another module of the same part number without any adjustment. There are two different FTM I/O configurations for the 48/24 Discrete Combo Module.

Configuration 1 consists of one 48/24 Discrete FTM connected to the 48/24 Discrete Combo module via two High Density Analog/Discrete cables. The 48/24 Discrete FTM is then connected to either two 16 Ch. Relay Modules or one 32 Ch. Relay Module via a Low Density Discrete Cable(s).

Configuration 2 consists of two 24/12 Discrete FTMs (DIN rail mounted) connected to the 48/24 Discrete Combo module via two High Density Analog/Discrete cables.

The discrete inputs are optically isolated and accessible through either the 48/12 Discrete FTM or the 24/12 Discrete FTM depending on the configuration. The discrete outputs are accessible through either the 24/12 Discrete FTM or the 2 16 Ch. Relay Modules or the 1 32 Ch. Relay Module when so configured. See Figures 7-14 and 7-19 for examples of configurations.



Figure 4-14. Discrete Combo Module

4.2.2—Module Specification

4.2.2.1. Discrete Inputs

Number of channels:	48
Update time:	5 ms
Input type:	Optically isolated discrete input (galvanically isolated)

4.2.2.2. 48/24 Discrete FTM

Input thresholds:	
Low voltage:	8 Vdc at 1.5 mA = "OFF" > 16 Vdc at 3 mA = "ON"
High voltage:	<29 Vdc at 1.8 mA = "OFF" >67 Vdc at 4 mA = "ON"
Input current:	4 mA @ 24 Vdc; 2.6–5 mA @ 125 Vdc
External input voltage:	18–32 Vdc (UL and LVD), or 100–150 Vdc (UL) w/ high Voltage FTM
Isolation voltage:	500 Vdc to earth ground, 1000 Vdc to control common
Time stamping:	1 ms resolution
Isolated 24 Vdc contact supply:	400 mA maximum

For the 24/12 Discrete FTM input specifications, see Chapter 12.

4.2.2.3. Discrete Outputs

Number of channels:	24
Update time:	5 ms

For the 24/12 Discrete FTM, 16 Ch. Relay Module, and the 32 Ch. Relay Module output specifications, see Volume 2, Chapter 12.

4.2.3—Installation

The modules slide into card guides in the control's chassis and plug into the motherboard. The modules are held in place by two screws, one at the top and one at the bottom of the front panel. Also at the top and bottom of the module are two handles which, when toggled (pushed outward), move the modules out just far enough for the boards to disengage the motherboard connectors.

There are two different FTM I/O configurations for the 48/12 Discrete Combo Module.

4.2.3.1. Configuration 1

Configuration 1 consists of one 24 Vdc or 125 Vdc 48/24 Discrete FTM connected to the 48/24 Discrete Combo module via two High Density Analog/Discrete cables. The top connector on the 48/24 Discrete Combo module, which is labeled J1, connects to J1 on the 48/24 Discrete FTM, and J2 connects to J2. There are two versions of the FTM, one for 24 Vdc inputs, and one for 125 Vdc inputs. The LVD applies only to the 24 Vdc version. The 24 Vdc 48/24 Discrete FTM handles 24 Vdc input signals and the 125 Vdc 48/24 Discrete FTM handles 125 Vdc input signals. Either 48/24 Discrete FTM is then connected to either two 16 Ch. Relay Modules or one 32 Ch. Relay Module via a Low Density Discrete Cable(s) via the third connector. See Figure 4-15 for an example of configuration.

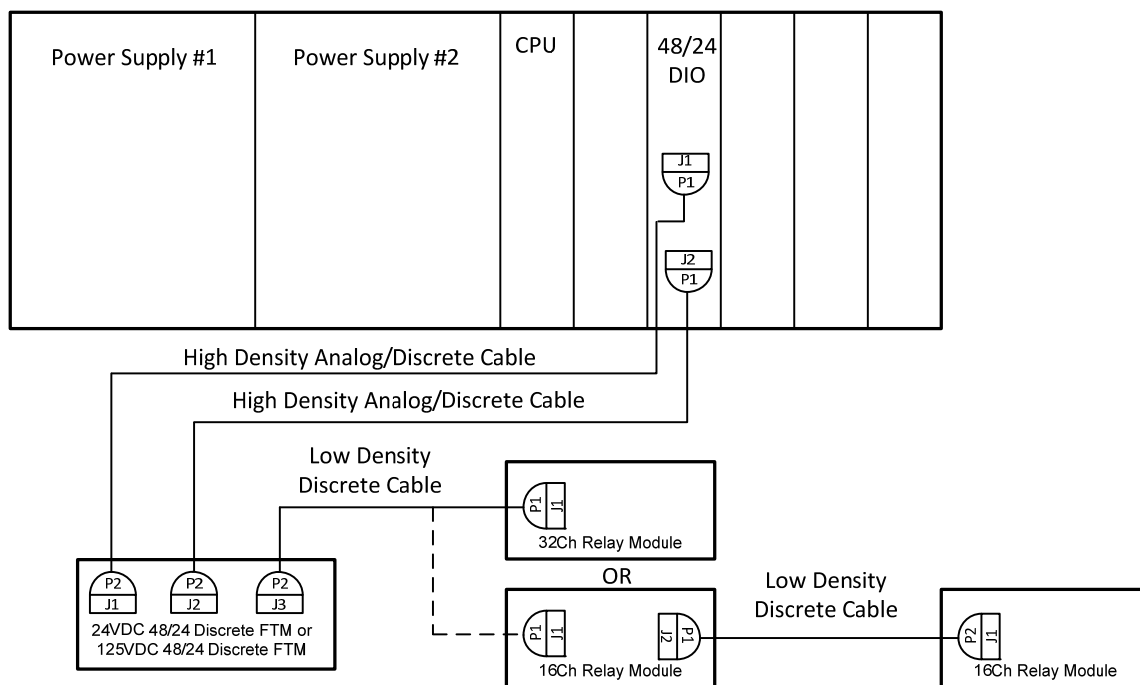

Figure 4-15. Configuration 1, One 48/24 Discrete FTM with Relay Module(s)

All of the discrete inputs on the module are accessible on the FTM, and the channels are labeled to correspond to their designation in the application software (discrete input 1 on the FTM will be discrete input 1 in the application software).

Discrete Inputs

Each 48/24 Discrete Combo module accepts 48 contact inputs. The 48/24 Discrete FTM may supply contact-wetting voltage. Optionally, an external 18–32 Vdc power source or an external 100–150 Vdc power source can be used to source the circuit wetting voltage. If the 24 Vdc internal power source is used for contact wetting, a jumper is required between FTM terminals 98 and 99. If an external power source is used for contact wetting, the external sources common must be connected to the FTM's discrete input common, terminal 49. If 125 Vdc contact inputs are needed, the High Voltage (125 Vdc) FTM must be used. The FTM provides a common cage-clamp terminal connection for customer field wiring. Figures 7-30 and 7-31 illustrate different discrete input wiring configurations based on the input voltage.

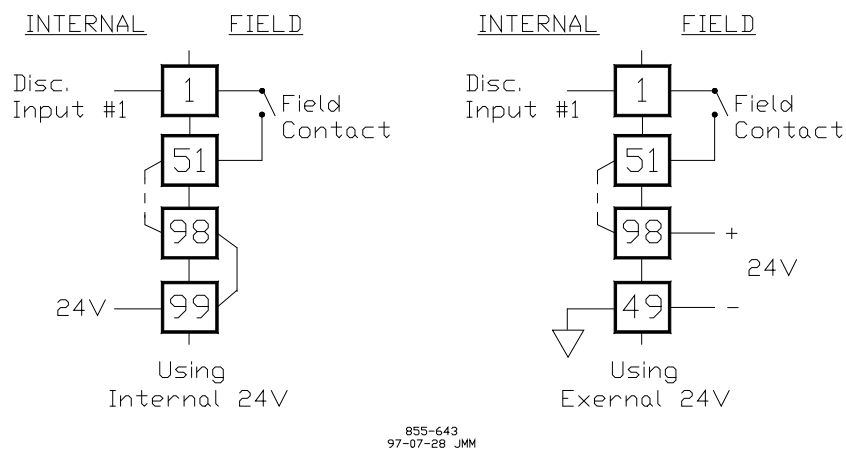

Figure 4-16. Discrete Input Interface Wiring to a 24 Vdc 48/24 Discrete FTM

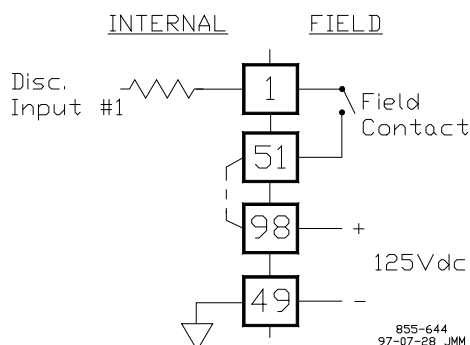

Figure 4-17. Discrete Input Interface Wiring to a 125 Vdc 48/24 Discrete FTM

! WARNING

HIGH VOLTAGE—If the high voltage FTM is being used, and there is 125 Vdc on the FTM terminal blocks, there will be 125 Vdc on the FTM sub D connectors and on the cable when it is connected to the FTM. For this reason, any power should be removed from the FTM terminal blocks before installing the 48/24 Discrete Combo module or the FTM.

Configuration Notes:

- Refer to Chapter 12 for Discrete Input wiring.
- Each 48/24 Discrete I/O module can only accept one input voltage range, 24 Vdc (LVD and UL) or 125 Vdc (UL only).
- All contact inputs accept dry contacts.

- 24 Vdc FTM only—If the internal 24 Vdc is used, a jumper must be added to tie the internal 24 Vdc to the bussed power terminal blocks (see Figure 6-16).
- 24 Vdc FTM only—If an external 24 Vdc is used, the common for the external 24 Vdc must be tied to the discrete input common (see Figure 6-16). Power for contacts must be supplied by the control's power supplies, or the external power supply outputs must be rated to Class II at 30 Vdc or less and outputs must be fused with appropriately sized fuses (a maximum current rating of $100 \div V$, where V is the supply's rated voltage or 5 A, whichever is less).
- High Voltage FTM only—the common for the 125 Vdc must be tied to the discrete input common (see Figure 7-14).

Discrete Outputs

For the 48/24 Discrete Combo FTM configuration, there are three types of relay output boxes that can be used. These consist of the 16 Ch. Relay (Phoenix) Module, 16 Ch. Relay Module, and the 32 Ch. Relay Module (see Chapter 12 for a description of the available modules). The relay modules connect to the 48/24 Discrete FTM through individual cables and provide a common cage-clamp terminal connection for customer field wiring. The discrete outputs on the 48/24 Discrete I/O module are non-isolated; the isolation takes place in the relay boxes.

Discrete outputs 9, 10, 11, 12, 21, 22, 23, and 24, drive two relays per output (see Table 7-5). Internal wiring on the 48/24 Discrete I/O FTM provides this dual relay functionality. The application software may use these relays for outputs where extra relay contacts are needed, such as alarm or shutdown outputs.

Table 4-2. Discrete Outputs/Relay Module Configuration

Discrete Outputs	16 Channel Relay Mod.(s)	32 Channel Relay Mod.
1-8	Mod. 1 Ch. 1-8	Ch. 1-8
9	Mod. 1 Ch. 9, 10	Ch. 9,10
10	Mod. 1 Ch. 11, 12	Ch. 11, 12
11	Mod. 1 Ch. 13, 14	Ch. 13, 14
12	Mod. 1 Ch. 15, 16	Ch. 15, 16
13-20	Mod. 2 Ch. 1-8	Ch. 17-24
21	Mod. 2 Ch. 9, 10	Ch. 25, 26
22	Mod. 2 Ch. 11, 12	Ch. 27, 28
23	Mod. 2 Ch. 13, 14	Ch. 29, 30
24	Mod. 2 Ch. 15, 16	Ch. 31, 32

See Volume 2, Chapter 12 for field wiring of discrete output relays.

Figures 4-20 and 4-21 illustrate examples of different discrete output wiring configurations.

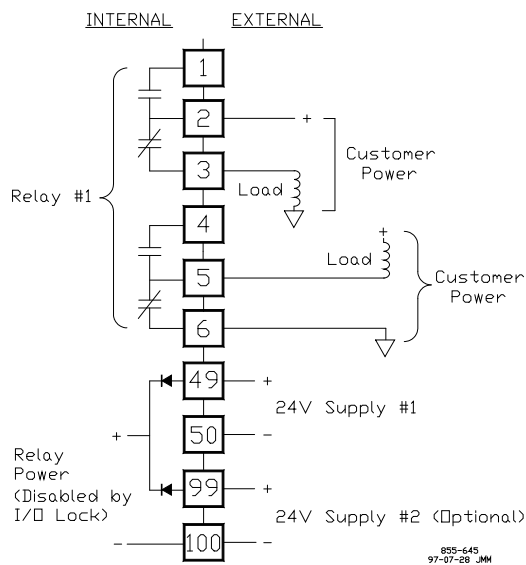

Figure 4-18. Relay Output Interface Wiring to a 16 Ch. Relay Module

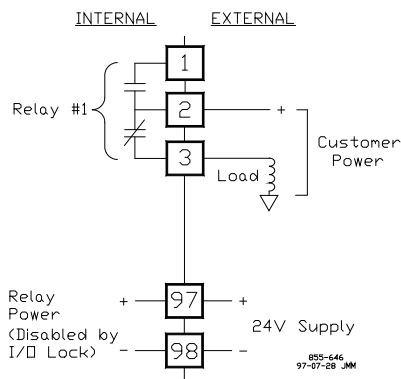

Figure 4-19. Relay Output Interface Wiring to a 32 Ch. Relay Module

Configuration Notes

Verify that each set of relay contacts meets the power requirements of the circuit with which it is being used. Interposing relays are required when the interfaced circuit demands relay contacts with a higher power rating. If interposing relays or other inductive loads are required, it is recommended that interposing relays with surge (inductive kickback) protection be used. Improper connection could cause serious equipment damage.

4.2.3.2. Configuration 2

Configuration 2 consist of two 24/12 Discrete FTMs (DIN rail mounted) connected to the 48/24 Discrete Combo module via two High Density Analog/Discrete cables. See Figure 7-40 for an example of configuration.

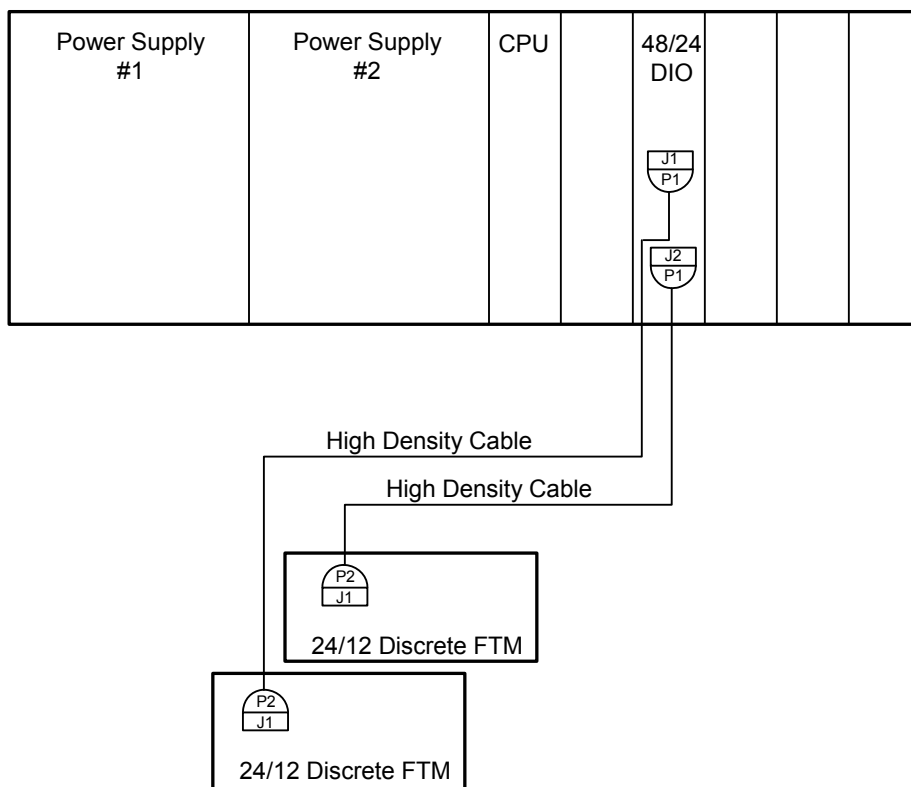

Figure 4-20. Configuration 2, Two 24/12 Discrete FTMs

Both the 48 discrete inputs and 24 discrete outputs are wired to the 24/12 Discrete FTM. An external 24 Vdc source connection to the FTM is required for discrete input contact sensing and relay coil energizing. For wiring information on the 24/12 Discrete FTM, see Volume 2, Chapter 12.

Discrete Inputs

Each 24/12 Discrete FTM accepts 24 contact inputs. The 24/12 Discrete FTM may supply contact-wetting voltage. Optionally, an external 18–32 Vdc power source can be used to source the circuit wetting voltage. If the 24 Vdc internal power source is used for contact wetting, a jumper is required between FTM terminals on TB9. If an external power source is used for contact wetting, the external source's common must be connected to the FTM's discrete input common, terminal 49 (see Figure 4-21).

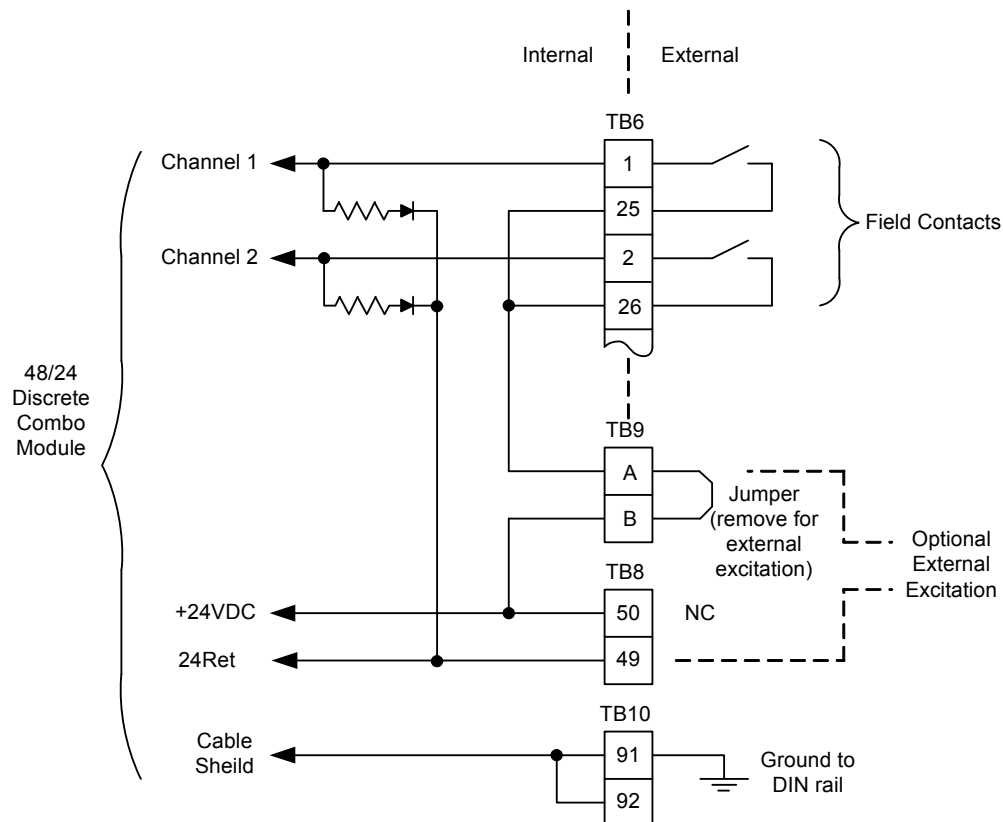

Figure 4-21. Discrete Input Interface Wiring to a 24/12 Discrete FTM

Configuration Notes:

- Refer to Chapter 12 for Discrete Input wiring.
- All contact inputs accept dry contacts.
- If the internal 24 Vdc is used, a jumper must be added to tie the internal 24 Vdc to the bussed power terminal blocks (see Figure 4-21).
- If an external 24 Vdc is used, the common for the external 24 Vdc must be tied to the discrete input common (see Figure 4-21). Power for contacts must be supplied by the control's power supplies, or the external power supply outputs must be rated to Class II at 30 Vdc or less and outputs must be fused with appropriately sized fuses (a maximum current rating of $100/V$, where V is the supply's rated voltage, or 5 A, whichever is less).

Discrete Outputs

The discrete outputs on the 48/24 Discrete I/O module are non-isolated; the isolation takes place in the 24/12 Discrete FTM. See Chapter 12 for field wiring of discrete output relays. Figure 4-22 illustrates an example of a discrete output-wiring configuration.

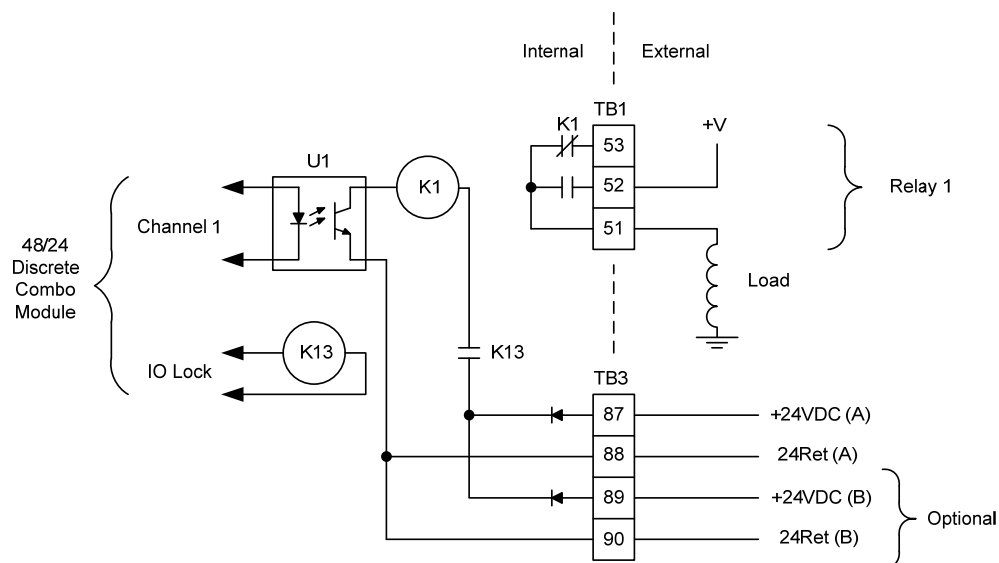

Figure 4-22. Relay Output Interface Wiring to a 24/12 Discrete FTM

Configuration Note

Verify that each set of relay contacts meets the power requirements of the circuit with which it is being used. Interposing relays are required when the interfaced circuit demands relay contacts with a higher power rating. If interposing relays or other inductive loads are required, it is recommended that interposing relays with surge (inductive kickback) protection be used. Improper connection could cause serious equipment damage.

4.2.4—FTM Reference

See Chapter 12 for detailed wiring of FTMs. See Appendix A for part number Cross Reference for modules, FTMs, and cables.

4.2.5—Troubleshooting

4.2.5.1. Fault Detection (Module Hardware)

Each 48/24 Discrete Combo module has a red Fault LED that is turned on when the system is reset. During initialization of a 48/24 Discrete Combo module, which occurs after every CPU reset, the CPU turns the Fault LED on. The CPU then tests each 48/24 Discrete Combo module using diagnostic routines built into the software. If the diagnostic test is not passed, the LED remains on or blinks. If the test is successful, the LED goes off. If the Fault LED on a 48/24 Discrete Combo module is illuminated after the diagnostics and initialization have been run, the module may be faulty or may be located in the wrong slot.

Table 4-3. LED Indications of Failure

Number of LED Flashes	Failure
2	Micro-controller internal RAM test failure
3	External RAM high and low byte test failure
4	External RAM low byte failure
5	External RAM high byte failure
6	EEPROM failure
7	Software not running
8	System monitor fault
9	MFT pulses missing

4.2.5.2. Fault Detection (I/O)

In addition to detecting 48/24 Discrete I/O module hardware faults, the application software may detect I/O faults.

Discrete Output Faults: The module monitors the FTM control voltage and annunciates faults. The application software determines the course of action in the event of a fault.

Microcontroller Faults: The system monitors a software watchdog, a hardware watchdog, and a software watchdog on the VME bus communications. All outputs are shut down in the event of a microcontroller fault.

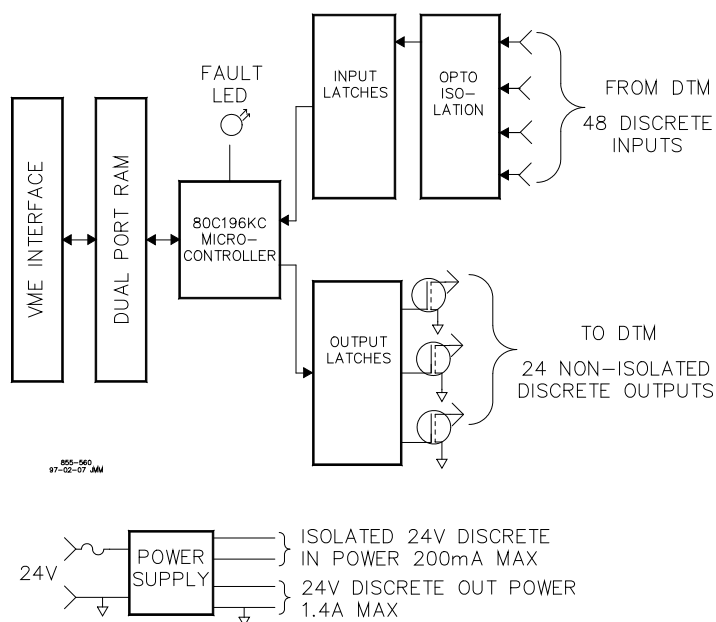

Figure 4-23. 48/24 Discrete Combo Module Block Diagram

If during normal control operation all of a chassis' 48/24 Discrete Combo modules have Fault LEDs on, check the chassis' CPU module for a failure. If during normal control operation, only the 48/24 Discrete Combo module's Fault LED is on or flashing, insures that it is installed in the correct slot. If it is, then replace that 48/24 Discrete Combo module. When a module fault is detected, its outputs should be disabled or de-energized.

4.2.5.3. Discrete Inputs

If a discrete input is not functioning properly, verify the following:

1. Measure the input voltage on the terminal block. It should be in the range of 16–32 Vdc for the low voltage FTM or 100–150 Vdc for the high voltage FTM.
2. Check the wiring. If the inputs are reading open, look for a loose connection on the terminal blocks, disconnected or misconnected cables, or a missing jumper on the terminal block.
3. Check the application software configuration to ensure that the input is configured properly.
4. If the other channels on the 48/24 Discrete Combo module are not working either, check the fuse on the 48/24 Discrete Combo module. See the instructions in Chapter 15 for replacing the module. This fuse is visible and can be changed through the bottom of the module. If this fuse is blown, fix the wiring problem and replace the fuse with another fuse of the same type and rating.
5. After verifying all of the above, exchange the J1 and J2 cables. If the problem moves to a different channel, replace the cable. If not, replace the 48/24 Discrete Combo module.
6. If the readings are incorrect on several channels of the 48/24 Discrete Combo module, corresponding to both cables, replace the 48/24 Discrete Combo module.
7. If replacing the module does not fix the problem, replace the FTM. See the instructions in Chapter 15 for replacing the FTM.

4.2.5.4. Discrete Outputs

If a discrete output is not functioning properly, verify the following:

1. Check the wiring for a loose connection on the terminal blocks, or disconnected or misconnected cables.
2. Verify that the current through the relay contacts is not greater than the relay contact rating.
3. If the other output channels on the 48/24 Discrete Combo module are not working either, check the fuse on the 48/24 Discrete Combo module. See the instructions in Chapter 15 for replacing the module. This fuse is visible and can be changed through the bottom of the module. If this fuse is blown, fix the wiring problem and replace the fuse with another fuse of the same type and rating.
4. Check the software configuration to ensure that the output is configured properly.
5. After verifying all of the above, exchange the J1 and J2 cables. If the problem moves to a different channel, replace the cable. If not, exchange the cables at the FTM, so J1 is driving J2 and vice versa. If the problem moves to a different relay, replace the 48/24 Discrete Combo module. If the fault stays with the same relay, replace the relay or the relay module. See instructions for replacing the relay modules in Chapter 15. If replacing the relay module does not fix the problem, replace the cable between the relay module and the FTM, or replace the FTM itself. See the instructions in Chapter 15 for replacing the FTM.

4-3. 32 Channel Discrete Output Module

4.3.1—Module Description

The MicroNet control can provide discrete outputs to the prime mover from field wiring. Each Discrete Output (DO) module can individually control 32 outputs according to commands from the CPU module. These modules have no potentiometers and require no calibration. A module may be replaced with another module of the same part number without any adjustment. There are two different FTM I/O configurations for the 32 Ch. DO Module. The module can be connected to one 32 Ch. Relay Module or two 16 Ch. Relay Modules (see Chapter 12 for additional information on the relay modules).

4.3.2—Module Specification

Number of channels:	32
Update time:	5 ms
Output Type:	Open drain drivers, intended for use with Woodward relay interface modules.
Fault Detection Readback:	Output channel status, relay status is not available
System Faults:	Outputs are turned off if communications with the CPU is lost.

For the 16 Ch. Relay Module and the 32 Ch. Relay Module output specifications, see Chapter 12.



Figure 4-24. Discrete Output Module

4.3.3—Installation

The modules slide into card guides in the control's chassis and plug into the motherboard. The modules are held in place by two screws, one at the top and one at the bottom of the front panel. Also at the top and bottom of the module are two handles which, when toggled (pushed outward), move the modules out just far enough for the boards to disengage the motherboard connectors.

This module receives digital data from the CPU and generates 32 non-isolated relay driver signals. All discrete output modules in the system interface to one or more Woodward Relay Modules, each with 16 or 32 relays. The contacts of these relays then connect to the field wiring.

A separate 24 Vdc power source must be provided for the relays; this module does not furnish this power. A section of a multi-output Main Power Supply can be used, or power from a single-output Main Power Supply can be used, as long as sufficient current is available.

Each 32 Ch. DO Module is connected through one low-density discrete cable to a 32 Ch. Relay module or a 16 Ch. Relay module daisy chained to a second 16 Ch. Relay module with another low-density cable. See Figure 7-50 for system installation configuration.

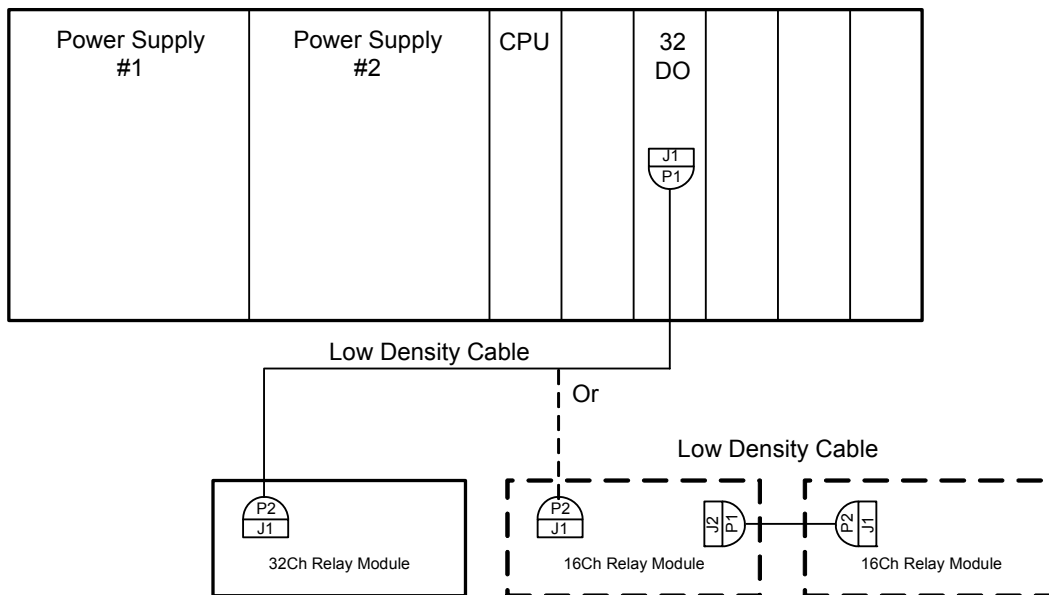

Figure 4-25. 32 Ch. DO Module with Relay Modules

See Volume 2, Chapter 12 for field wiring of discrete output relays.

Figures 4-26 and 4-27 illustrate examples different discrete output wiring configurations.

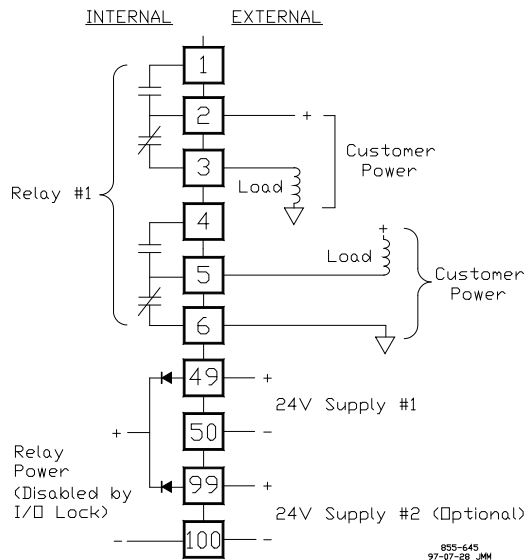

Figure 4-26. Relay Output Interface Wiring to a 16 Ch. Relay Module

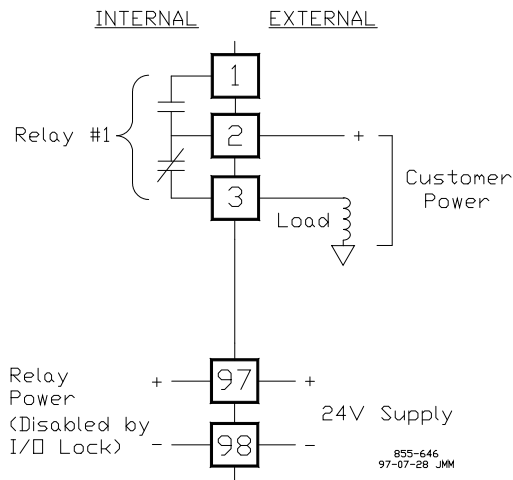

Figure 4-27. Relay Output Interface Wiring to a 32 Ch. Relay Module

Configuration Notes

Verify that each set of relay contacts meets the power requirements of the circuit with which it is being used. Interposing relays are required when the interfaced circuit demands relay contacts with a higher power rating. If interposing relays or other inductive loads are required, it is recommended that interposing relays with surge (inductive kickback) protection be used. Improper connection could cause serious equipment damage.

4.3.4—FTM Reference

See Chapter 12 for detailed wiring of relay modules. See Appendix A for part number Cross Reference for modules, FTMs, and cables.

4.3.5—Troubleshooting

Figure 4-28 is a block diagram of the 32-Channel Discrete Output module. The CPU sends the address of this module and the address and state of the channel to be output to this module. This information is received by the VME interface and passed to the latches. The latch associated with the channel to be output stores the information and passes it to the drivers. The driver for that channel then energizes or de-energizes the relay for that channel.

Each channel has a readback buffer that indicates the status of the output driver (not the relay). The CPU compares this status to the value written to the channel and generates a fault signal if these two values are different. The relay module power is turned off if communications with the CPU are lost or a fault is detected.

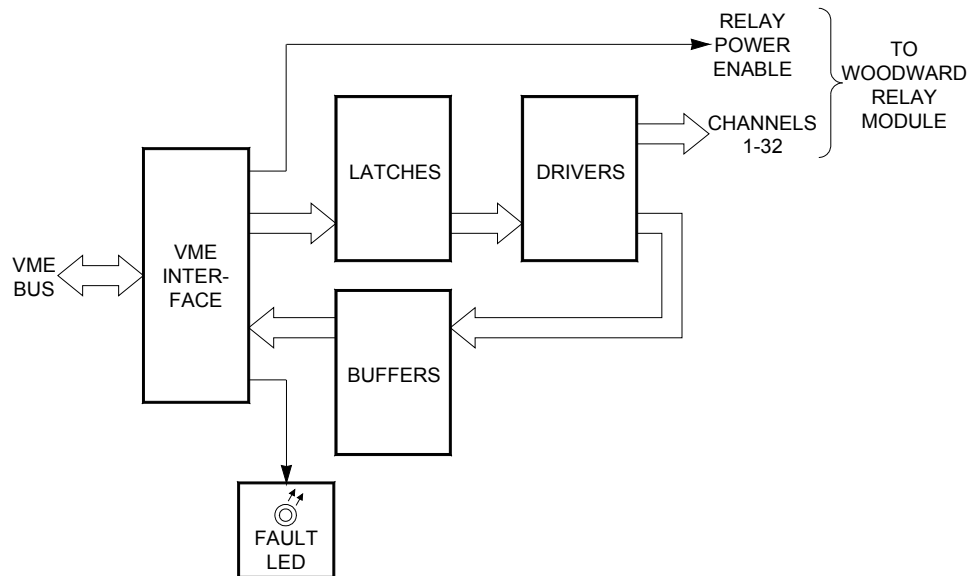

Figure 4-28. Discrete Output Module (32 Channel) Block Diagram

If a discrete output is not functioning properly, verify the following:

1. Check the wiring for a loose connection on the terminal blocks, or disconnected or misconnected cables.
2. Verify that the current through the relay contacts is not greater than the relay contact rating.
3. If the other output channels on the 32 Ch. DO module are not working either, check the fuse on the 32 Ch. DO module. See the instructions in Chapter 15 for replacing the module. This fuse is visible and can be changed through the bottom of the module. If this fuse is blown, fix the wiring problem and replace the fuse with another fuse of the same type and rating.
4. Check the software configuration to ensure that the output is configured properly.
5. If replacing the relay module does not fix the problem, replace the cable between the relay module and the FTM, or replace the FTM itself. See the instructions in Chapters 15 for replacing the FTM.

Chapter 5.

Analog I/O Modules

5.1. TMR 24/8 Analog Module

5.1.1—Module Description

A 24/8 Analog module contains circuitry for twenty-four analog inputs and eight 4–20 mA outputs. These modules have no potentiometers and require no calibration. A module may be replaced with another module of the same part number without any adjustment.

The TMR 24/8 Analog module comes in the following configuration: 24 channels of 4–20 mA inputs with 8 channels of 4–20 mA outputs (2-pole 10 ms filter on all input channels, except channels 23 and 24, which have 2-pole 5 ms filter).

All 4–20 mA analog inputs may be used with two-wire ungrounded (loop powered) transducers or isolated (self-powered) transducers. All analog inputs have 200 Vdc of common mode rejection. If interfacing to a non-isolated device, which may have the potential of reaching over 200 Vdc with respect to the control's common, the use of a loop isolator is recommended to break any return current paths producing erroneous readings.

Each board has an on-board processor for automatic calibration of the I/O channels. Each analog input incorporates a time-stamping feature with 5 ms resolution for two low setpoints and two high setpoints.



Figure 5-1. 24/8 Analog Module

5.1.2—Module Specification

5.1.2.1. Analog Input Ratings

Number of channels:	24
Update time:	5 ms
Input range:	0–25 mA; software and hardware selectable

IMPORTANT

The maximum voltage input range may vary between 4.975 and 5.025 Volts from module to module.

Isolation:	0 Vrms, 60 dB CMRR, 200 Vdc common mode rejection voltage; no galvanic isolation
Input imp. (4–20 mA):	200 ohms
Anti-aliasing filter:	2 poles at 10 ms
Resolution:	16 bits
Accuracy:	Software calibrated to 0.1%, over 0–25 mA full scale
Temp drift:	275 ppm/C, maximum
Fuse:	100 mA fuse per channel.

Time stamping: 5 ms resolution on low event and latch, and high event and latch

IMPORTANT

The 24 channel analog inputs are divided into two banks, with channel 1 through channel 12 data gathering at 1.8 ms after the MFT tick and channel 13 through channel 24 data gathering at 3.7 ms after the MFT tick.

5.1.2.2. 4–20 mA Output Ratings

Number of channels:	8
Update time:	5 ms
Output Driver:	Pulse Width Modulated (PWM)
PWM frequency:	6.14 kHz
Filter:	3 poles at 500 μ s
Current output:	4–20 mA
Current output range:	0–25 mA
Isolation:	0 Vrms
Max load resistance:	600 ohms (load + wire resistance)
Current readback:	8 bits
Readback isolation:	60 dB CMRR, 200 Vdc common mode rejection voltage
Resolution:	11 bits
Accuracy:	Software calibrated to 0.2% of 0–25 mA full scale
Temperature drift:	125 ppm/C, maximum
Readback accuracy:	0.5% of 0–25 mA full scale
Readback temp drift:	400 ppm/C, maximum

5.1.3—Installation

The modules slide into card guides in the control's chassis and plug into the motherboard. The modules are held in place by two screws, one at the top and one at the bottom of the front panel. Also at the top and bottom of the module are two handles which, when toggled (pushed outward), move the modules out just far enough for the boards to disengage the motherboard connectors.

Three 24/8 Analog I/O modules are connected through six high density 62 conductor analog cables (two from each module) to two 24/8 Analog I/O FTMs. Each 24/8 Analog I/O module has two sub D connectors on the front panel. The top sub D connector contains the first half of the channels (analog input channels 1-12 and analog output channels 1-4) and the bottom sub D connector contains the second half of the I/O channels. See Figure 8-2 for an example.

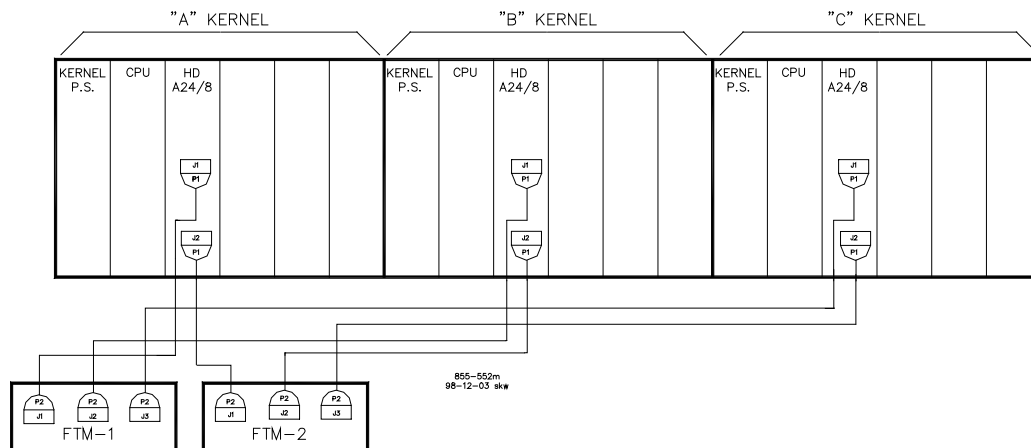

Figure 5-2. Example TMR System Configuration

Analog Inputs

For a 4–20 mA input signal, the 24/8 Analog Module uses a 200 ohm resistor across the input located on the 24/8 Analog Module. Each analog input channel may power its own 4–20 mA transducer. See Figure 8-3 for analog input connection. This power is protected with a 100 mA fuse on each channel to prevent an inadvertent short from damaging the module. The 24 Vdc outputs are capable of providing 24 Vdc with $\pm 10\%$ regulation. The maximum current is 0.8 A. Power connections can be made through terminals located on the 24/8 Analog FTMs. See Chapter 12 for complete field wiring information for the 24/8 Analog FTM.

IMPORTANT

When configuring the AI Combo block in GAP for 4-20mA input, set the Conf. input field to "2" for all inputs using the TMR Analog FTM. This will allow the block to use the module factory voltage calibration values with a gain factor for a 200 ohm external resistor on the TMR Analog FTM.

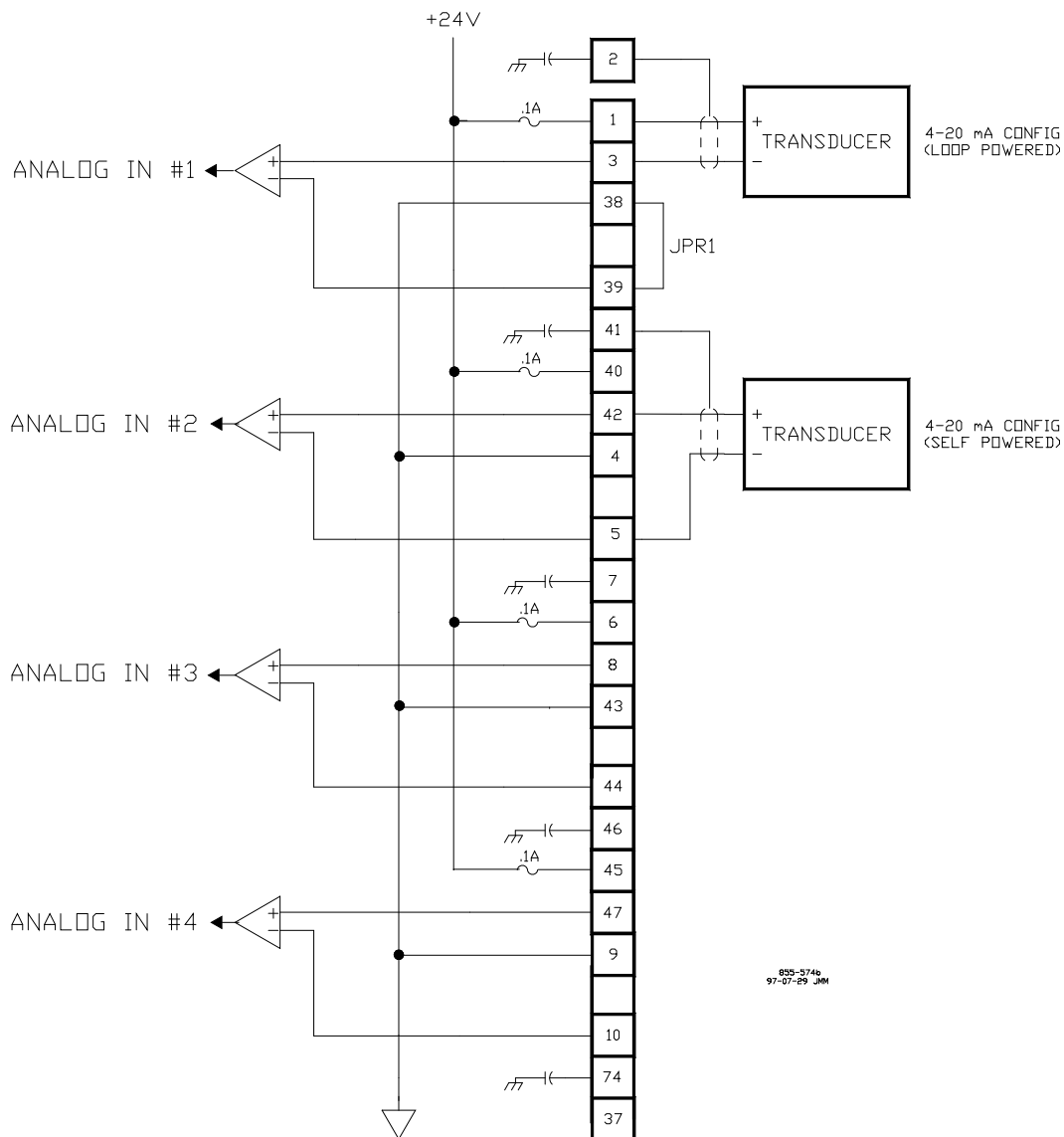

Figure 5-3. Analog Input Wiring for a 24/8 Analog FTM

Analog Outputs

There are eight analog output channels of 4–20 mA with a full-scale range of 0–25 mA. All Analog Outputs can drive a maximum load of 600 ohms (load + wire resistance). See Figure 8-4 for analog output connection. Each output monitors the output source current for fault detection. All of the analog outputs may be individually disabled. When a channel fault or a module fault is detected, the application program may annunciate the fault, disable the channel, and stop using data in system calculations or control. Care should be taken to prevent ground loops and other faults when interfacing to non-isolated devices. See Chapter 12 for complete field wiring information for the Analog High Density FTM.

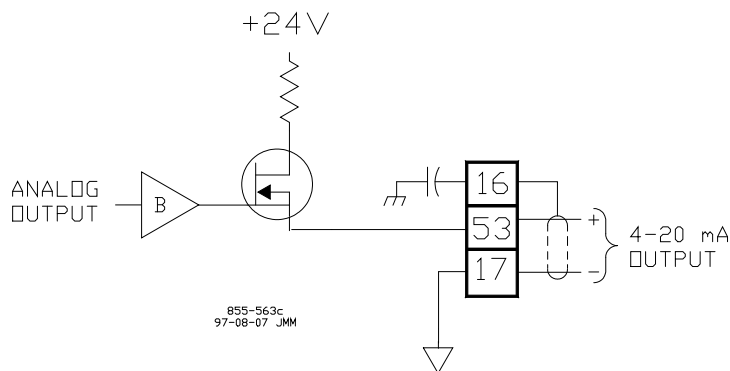

Figure 5-4. Analog Output Wiring for a 24/8 Analog FTM

5.1.4—FTM Reference

See Chapter 12 for complete field wiring information for the Analog High Density FTM. See Appendix A for part number Cross Reference for modules, FTMs, and cables.

5.1.5—Troubleshooting

Each 24/8 Analog module has a red Fault LED that is turned on when the system is reset. During initialization of a module, which occurs after every CPU reset, the CPU turns the Fault LED on. The CPU then tests each module using diagnostic routines built into the software. If the diagnostic test is not passed, the LED remains on or blinks. If the test is successful, the LED goes off. If the Fault LED on a module is illuminated after the diagnostics and initialization have been run, the module may be faulty or may be located in the wrong slot.

Table 5-1. LED Indications of Failure

Number of LED Flashes	Failure
1	Hardware watchdog, CPU clock failure, reset fail
2	Micro-controller internal RAM test failure
3	External RAM test failure
4	Unexpected exception error
5	Dual Port RAM test failure
6	EEPROM failure
7	Communications watchdog time out
8	EEPROM error is corrected (reset the module to continue)
9	Missing an A/D Converter interrupt

5.1.5.1. Fault Detection (I/O)

In addition to detecting the High Density Analog I/O module hardware faults, the application software may detect I/O faults.

Analog Input Faults: The application software may be set with a high and low latch setpoint to detect input faults.

Analog Output Driver Faults: The module monitors the source currents and annunciates faults. The application software determines the course of action in the event of a fault.

Microcontroller Faults: The system monitors a software watchdog, a hardware watchdog, and a software watchdog on the VME bus communications. All outputs are shut down in the event of a microcontroller fault.

Troubleshooting Guide

If during normal control operation all of a chassis' 24/8 Analog I/O modules have Fault LEDs on, check the kernel's CPU module for a failure. If during normal control operation only the 24/8 Analog I/O module's Fault LED is on or flashing, ensure that it is installed in the correct slot. If it is, then replace that 24/8 Analog I/O module. See instructions for replacing the module in Chapter 15, Installation and Service. When a module fault is detected, its outputs should be disabled or de-energized.

Analog Inputs

If an analog input is not functioning properly, verify the following:

- Check that the cable is shielded and the shield is properly grounded per the section on Shields and Grounding in Chapter 15, Installation and Service.
- Measure the input voltage on the terminal block. It should be in the range of 0–5 V.
- Look at the individual inputs into each kernel. Each 24/8 Analog I/O module reads the same input from the FTM, so the application software should contain three separate numbers, one from each 24/8 Analog I/O module. The numbers should be within 0.1% of each other unless a high common mode voltage is present.



The following actions may shut down the prime mover.

- If all of the 24/8 Analog I/O modules are reading approximately the same number, but the reading is incorrect, go to step 1. If two of the 24/8 Analog I/O modules are reading correctly, but one is reading incorrectly, go to step two.
- Check the wiring. If the inputs are reading zero or the engineering units that correspond to zero mA, look for a loose connection on the terminal blocks, disconnected or misconnected cables, a missing jumper on the terminal block if the input is a loop powered current input, or a blown fuse on the 24 Vdc on the FTM. See instructions for replacing the fuse on the FTM below. If all of the inputs are reading high, check to ensure that the 24 Vdc is not connected across the input directly. Check the fuse on the 24/8 Analog I/O module. See instructions for replacing the module in Chapter 15, Installation and Service. This fuse is visible and can be changed through the bottom of the module. If this fuse is blown, fix the wiring problem and replace the fuse with a fuse of the same type and rating. Check the application software configuration to ensure that the input is configured properly. If the connections and application software are verified and the correct voltage is present on the terminal block, but all of the 24/8 Analog I/O modules are reading 0 V, exchange FTM #1 with FTM #2. See instructions for replacing the FTM in Chapter 15. If the problem follows the FTM, replace the FTM. The FTM contains only a wire wound 3 W resistor and traces, so failure is extremely unlikely.
- If one or two of the 24/8 Analog I/O modules are reading the correct number, but the other 24/8 Analog I/O module(s) is (are) incorrect, check the application software configuration of the modules with the non-working channels, and check to ensure that the cables are connected properly. If the other channels on the same 24/8 Analog I/O module are not working either, check the fuse on the 24/8 Analog I/O module. See instructions for replacing the module in Chapter 15, Installation and Service. This fuse is visible and can be changed through the bottom of the module. If this fuse is blown, fix the wiring problem and replace the fuse with a fuse of the same type and rating. If the reading is still incorrect, but the other readings from the 24/8 Analog I/O module are correct, remove the 24/8 Analog I/O module and exchange the J1 and J2 cables. If the problem moves to a different channel, replace the cable. If not, replace the 24/8 Analog I/O module. If the readings are incorrect on several channels of the 24/8 Analog I/O module, corresponding to both cables, replace the 24/8 Analog I/O module.

Analog Outputs

If an analog output is not functioning properly, verify the following:

- Check that the cable is shielded and the shield is properly grounded Shields and Grounding section in Chapter 15, Installation and Service.
- Check the load resistance to ensure that it is below 600 ohms.
- Check to ensure that the load wiring is isolated.



CAUTION

The following actions may shut down the prime mover.

- Disconnect the field wiring and connect a resistor across the output. If the output current is 0 mA, go to step one. If the output current is correct, but some of the outputs have a fault, go to step two.
- Check the wiring for a loose connection on the terminal blocks or disconnected or misconnected cables. If none of the outputs on a given 24/8 Analog I/O module are functioning, check the 24/8 Analog I/O module fuse. See instructions for replacing the module in Chapter 15, Installation and Service. This fuse is visible and can be changed through the bottom of the module. If the fuse is blown, fix the wiring problem and replace the fuse with a fuse of the same type and rating. Check the application software configuration to ensure that the output is configured properly. If the connections and application software are verified, exchange FTM #1 with FTM #2. See instructions for replacing the FTM in Chapter 15. If the problem follows the FTM, replace the FTM. The FTM contains only traces and a few discrete components, so failure is extremely unlikely.
- If one or two of the 24/8 Analog I/O modules have an output fault, but the other module(s) does (do) not, check the application software, and check to ensure that the cables are connected properly. If the other output channels on the same 24/8 Analog I/O module are also not working, check the fuse on the 24/8 Analog I/O module. See instructions for replacing the module in Chapter 15, Installation and Service. This fuse is visible and can be changed through the bottom of the module. If the fuse is blown, fix the wiring problem and replace the fuse with a fuse of the same type and rating. If the output still has a fault, but the other output channels on the 24/8 Analog I/O module are functioning properly, remove the 24/8 Analog I/O module and exchange the J1 and J2 cables. If the problem moves to a different channel, replace the cable. If not, replace the 24/8 Analog I/O module. If the readings are incorrect on several channels of the 24/8 Analog I/O module, corresponding to both cables, replace the same 24/8 Analog I/O module.

5.1.5.5. Replacing a Fuse on the Field Terminal Module (FTM)

1. Verify that the condition that caused the fuse to blow has been corrected.



CAUTION

If power has not been removed from the control system, power will be active at the module and at the FTM. Shorting of protected circuitry could cause a control system shutdown.

2. Remove FTM cover carefully, to prevent contact with any FTM circuitry under the cover. To remove the FTM cover, pinch the retaining barb and lift the cover.
3. Locate and replace the fuse with another fuse of the same size, type, and rating. See Figure 12-12 or Figure 12-13 for channel fuse location.
4. Replace the FTM Cover.

5.2. TMR Analog Combo Module – 3 MPU, 1 Prox

5.2.1—Module Description

Each 3 MPU, 1 Prox High Density Analog Combo module contains circuitry for three passive speed sensor inputs (magnetic pickups), one proximity probe (active probe, low speed detection only), eight analog inputs, four analog outputs, and two proportional actuator driver outputs.

Each analog input must be 4–20 mA, and each actuator driver may be configured as 4–20 mA or 20–160 mA.

There are three configurations of the Analog Combo Modules. One has the analog inputs configured for 4–20 mA and the other two are configured for 0–5 V. 0–5 V modules are the ones used for TMR, see Appendix A for specific part numbers. In addition to the module, the FTM configuration determines if the 0–5 V or 4–20 mA AI's are available. In a simplex configuration, either Analog Combo module, 4–20 mA or 0–5 V is connected through two analog cables to one Analog Combo FTM. All of the I/O are accessible on the FTM, and the channels are labeled to correspond to their software locations, e.g. analog input 1 on the FTM will be analog input 1 in the application software.

This module includes no potentiometers and requires no calibration. An Analog Combo module may be replaced with another module of the same part number without any adjustment.



Figure 5-5. Analog Combo Module

5.2.2—Module Specifications

5.2.2.1. Digital Speed Sensor Inputs

Number of channels:	4
Update time:	5 ms

5.2.2.2. MPU Input Ratings

Input frequency:	100 - 25000 Hz
Input amplitude:	1-25 Vrms
Input impedance:	2000 Ohms
Isolation voltage:	500 Vrms
Resolution:	12 bits minimum over chosen frequency range
Accuracy:	0.03% full scale, minimum

5.2.2.3. Proximity Probe Input Ratings

Input frequency:	0.5–25 000 Hz (Only intended as turning gear detection)
Input amplitude:	3.5 - 32 Vdc input to the module
Available power:	12 Vdc or 24 Vdc, 50 mA maximum
Isolation voltage:	0 Vrms
Resolution:	12 bits minimum over chosen frequency range
Accuracy:	Software calibrated to 0.03% full scale
Fuse:	24 Vdc 100 mA fuse/channel, 12 Vdc short circuit protected
Time Stamping:	5-millisecond resolution on low event and low latch

5.2.2.4. Analog Input Ratings

Number of channels:	8
Update time:	5 millisecond
Input range:	0–25 mA

IMPORTANT

The maximum input voltage range may vary between 4.975 and 5.025 Volts from module to module.

Isolation:	0 VRMS, -60 dB CMRR, 200 Vdc common mode rejection voltage; no galvanic isolation
Input impedance:	200 ohms
Anti-aliasing filter:	2 poles at 10 ms
Resolution:	16 bits
Accuracy:	Software calibrated to 0.1%, over 25 mA full scale
Temp drift:	275 ppm/C, maximum
Fuse:	100 mA fuse per channel
Time stamping:	5 ms resolution on low event and latch, and high event and latch

5.2.2.5. 4–20 mA Analog Output Ratings

Number of channels:	4
Update time:	5 ms
Driver:	Pulse Width Modulated (PWM)
PWM frequency:	6.14 kHz
Filter:	3 poles at 500 ms
Current output:	4–20 mA current output range: 0 - 25 mA
Isolation:	0 Vrms
Max load resistance:	600 ohms (load + wire resistance)
Current readback:	11 bits
Readback isolation:	-60 dB CMRR, 200 Vdc common mode
Resolution:	11 bits
Accuracy:	Software calibrated to 0.2%, over 25 mA full scale
Temperature drift:	125 ppm/C, maximum
Readback accuracy:	0.2%, over 25 mA full scale
Readback temp drift:	400 ppm/C, maximum

5.2.2.6. Actuator Driver Output Ratings

Number of channels:	2
Update time:	5 millisecond
Driver:	PWM (proportional only), single or dual coil
PWM frequency:	6.14 kHz
Filter:	3 poles at 500 microseconds
Current output:	4–20 mA or 20–160 mA, software selectable
Current output range:	0–24 mA or 0–196 mA, depending on the selected range
Isolation:	0 Vrms
Max. act resistance	45 ohms on the 20–160 mA output, 360 ohms on the 4–20 mA output
Readback	Actuator source and return currents
Readback isolation	-60 dB CMRR, 200 Vdc common mode
Dither current	25 Hz, fixed duty cycle, software variable amplitude
Resolution	11 bits over 25 or 200 mA range
Accuracy	Software calibrated to 0.2% of 25 or 200 mA range
Temperature drift	125 ppm/C, maximum
Readback accuracy	0.1% of 25 or 200 mA range
Readback temp drift	150 ppm/C, maximum

5.2.3—Installation

The modules slide into card guides in the control's chassis and plug into the motherboard. The modules are held in place by two screws, one at the top and one at the bottom of the front panel. Also at the top and bottom of the module are two handles which, when toggled (pushed outward), move the modules out just far enough for the boards to disengage the motherboard connectors.

Three TMR Analog Combo Modules (MPU and Analog I/O modules) are connected through six analog cables (two from each module) to two FTMs. Each MPU and Analog I/O module has two sub D connectors on the front panel. The top sub D connector contains the first half of the channels (speed sensor channels 1 and 2, actuator channel 1, analog output channels 1 and 2, and analog input channels 1-4), and the bottom sub D connector contains the second half of the I/O channels. See Figure 8-14 for an example.

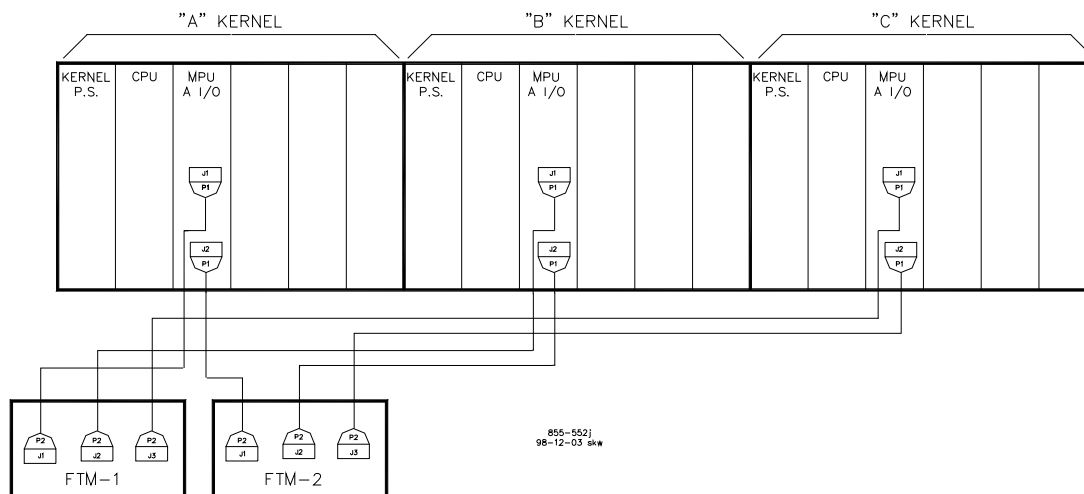

Figure 5-6. Example Fault Tolerant System Configuration

5.2.3.1. Field Wiring

See Chapter 12 for detail wiring connections for the TMR Analog Combo FTM. Wire each channel per the following examples for each type of signal.

5.2.3.2. Speed Sensor Inputs

The MPU and proximity probe inputs are read and the speed is provided to the application program. A derivative output is provided via the application software if desired. The Analog Combo module filters the speed sensor inputs and the filter time constant is selectable through the application software program at 8 milliseconds or 16 milliseconds. Eight milliseconds should be acceptable for most applications. 16 milliseconds may be necessary for very slow speed applications. The speed range determines the maximum speed that the module will detect. The control output of the software will detect a minimum speed of one fiftieth of the speed range. This allows detection of failed speed sensors to help prevent overspeed due to slow update times at very low speeds. The monitor output of the GAP block will read down to 0.5 Hz, irrespective of the speed range. An application may only use the combination of three MPU and one-proximity probes, and any combination of speed ranges.

The first three channels of the control accept passive magnetic pickup units (MPUs) and channel 4 accepts 12 or 24 Vdc proximity probes. (Channel 4 proximity probe is to be used for slow speed detection only.) Each speed input channel can only accept one MPU or one proximity probe.

A proximity probe may be used to sense very low speeds. With a proximity probe, speed can be sensed down to 0.5 Hz. When interfacing to open collector type proximity probes, a pull-up resistor is required between the supplied proximity probe voltage and the proximity probe input to the FTM. Individually fused 12 Vdc (via 24 Vdc) and 24 Vdc sources are provided with each speed input to power system proximity probes (100 mA fuses, located on the FTMs, are used). External pull-up resistors are required when interfacing with an open collector type proximity probe. The proximity probe input (channel 4) is only designed to be used as a turning gear input, but will detect signals up to 25,000 Hz. This input may not be used for control purposes, other than to indicate the turbine is not operating and is in pre-powered mode being turned by the turning gear.

See Figures 8-15 and 8-16 for MPU/proximity probe wiring example. Channel 1 shows an MPU connection, channel 2 shows a 24 V proximity connection, and channel 3 is an example of a 12 V proximity connection. Always jumper the unused MPU connection to eliminate possible noise interference when connecting a proximity probe.

IMPORTANT

It is not recommended that gears mounted on an auxiliary shaft coupled to the rotor be used to sense speed. Auxiliary shafts tend to turn more slowly than the rotor (reducing speed-sensing resolution) and have coupling gear backlash, resulting in less than optimum speed control. For safety purposes, it is also not recommended that the speed sensing device sense speed from a gear coupled to a mechanical drive side of a system's rotor coupling.

IMPORTANT

When a speed sensor input channel has been wired as *either* MPU or proximity probe input, the unused MPU/Prox must be jumpered at the FTM. When an input channel is not used, both the MPU and Prox inputs must be jumpered. See example in Figures 8-15 and 8-16.

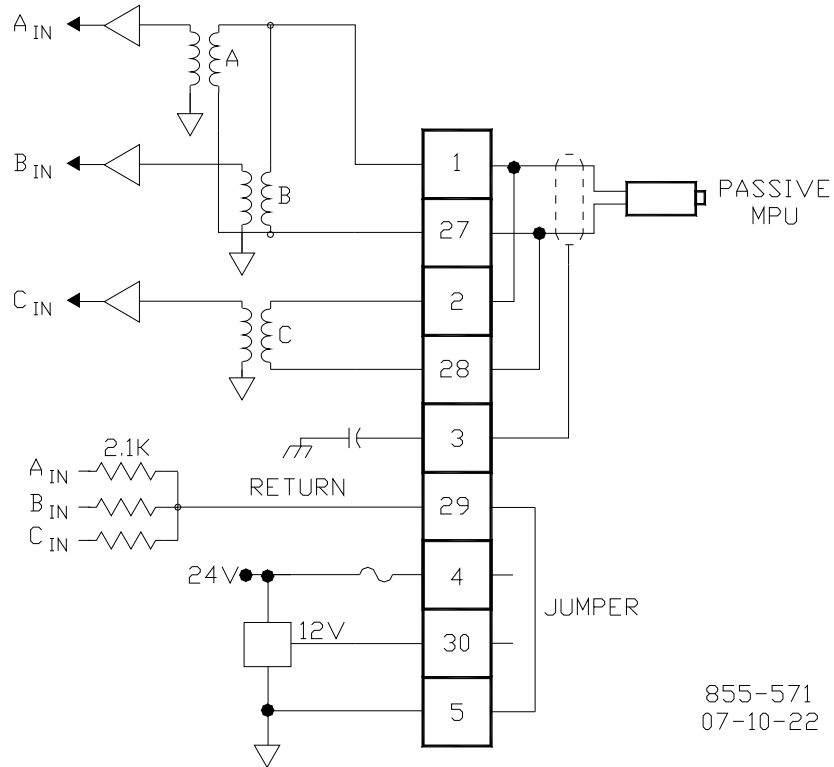

Figure 5-7. MPU Interface Wiring to TMR Analog Combo FTM (Speed 1-3)

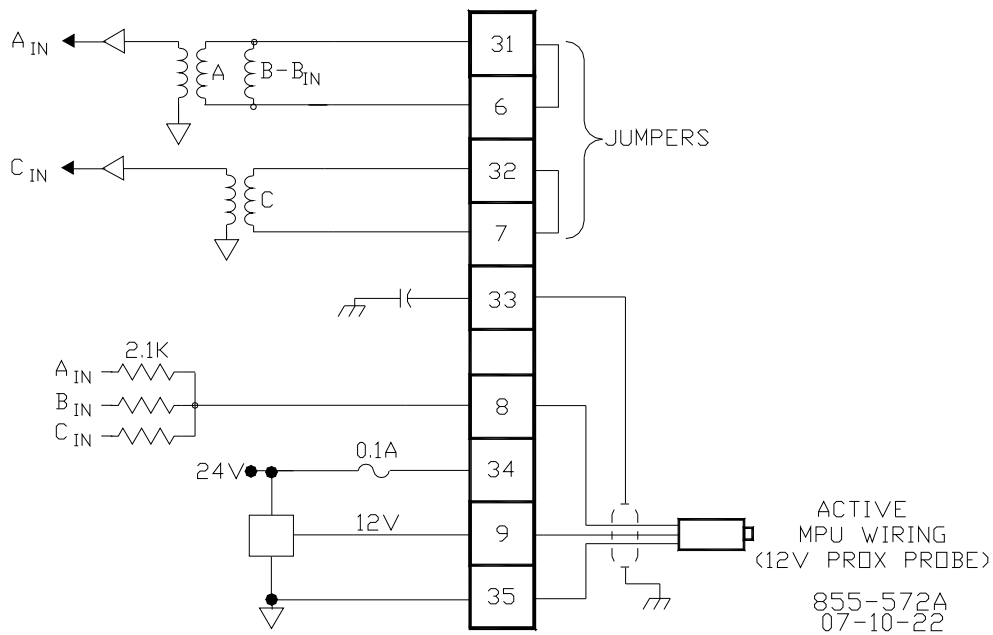

Figure 5-8. Prox Interface Wiring to TMR Analog Combo FTM (Speed 4)

Analog Inputs

The TMR analog inputs must be current type due to the TMR FTM. See Appendix A for specific part numbers. All modules use the same cable and FTMs.

All current inputs may be used with two-wire ungrounded (loop powered) transducers or isolated (self-powered) transducers. All analog inputs have 200 Vdc of common mode rejection. If interfacing to a non-isolated device, which may have the potential of reaching over 200 Vdc with respect to the control's common, the use of a loop isolator is recommended to break any return current paths that may produce erroneous readings. All current inputs use 200-ohm resistors across their inputs.

Each current input channel may power its own 4–20 mA transducer. This power is protected with a 100 mA fuse on each channel to prevent an inadvertent short from damaging the module. The 24 Vdc outputs are capable of providing 24 Vdc with $\pm 10\%$ regulation. Power connections can be made through terminals located on the FTMs. Refer to Figure 5-9 for 4–20 mA Current Input wiring.

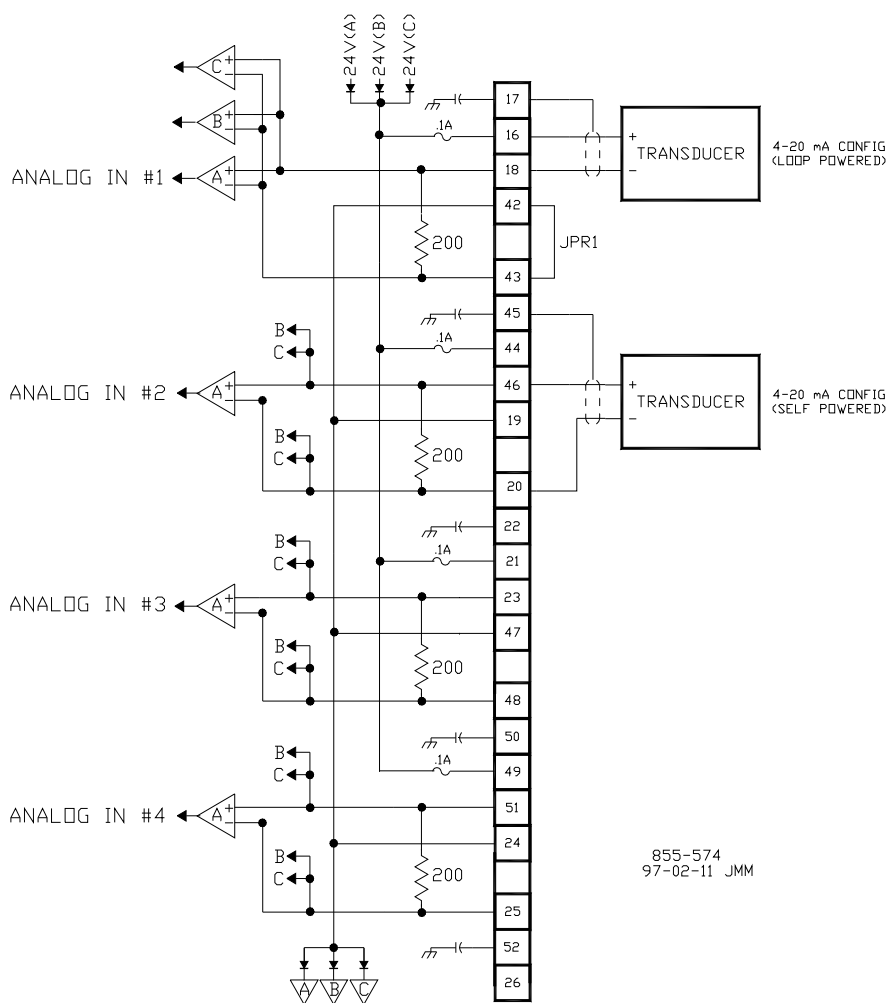

Figure 5-9—Current Input Wiring for an Analog Combo Module FTM

Only self-powered voltage transducers should be used on voltage input channels. The full-scale range must not exceed 5 volts. Refer to Figure 5-10 for 0–5 Vdc voltage transducer input wiring.

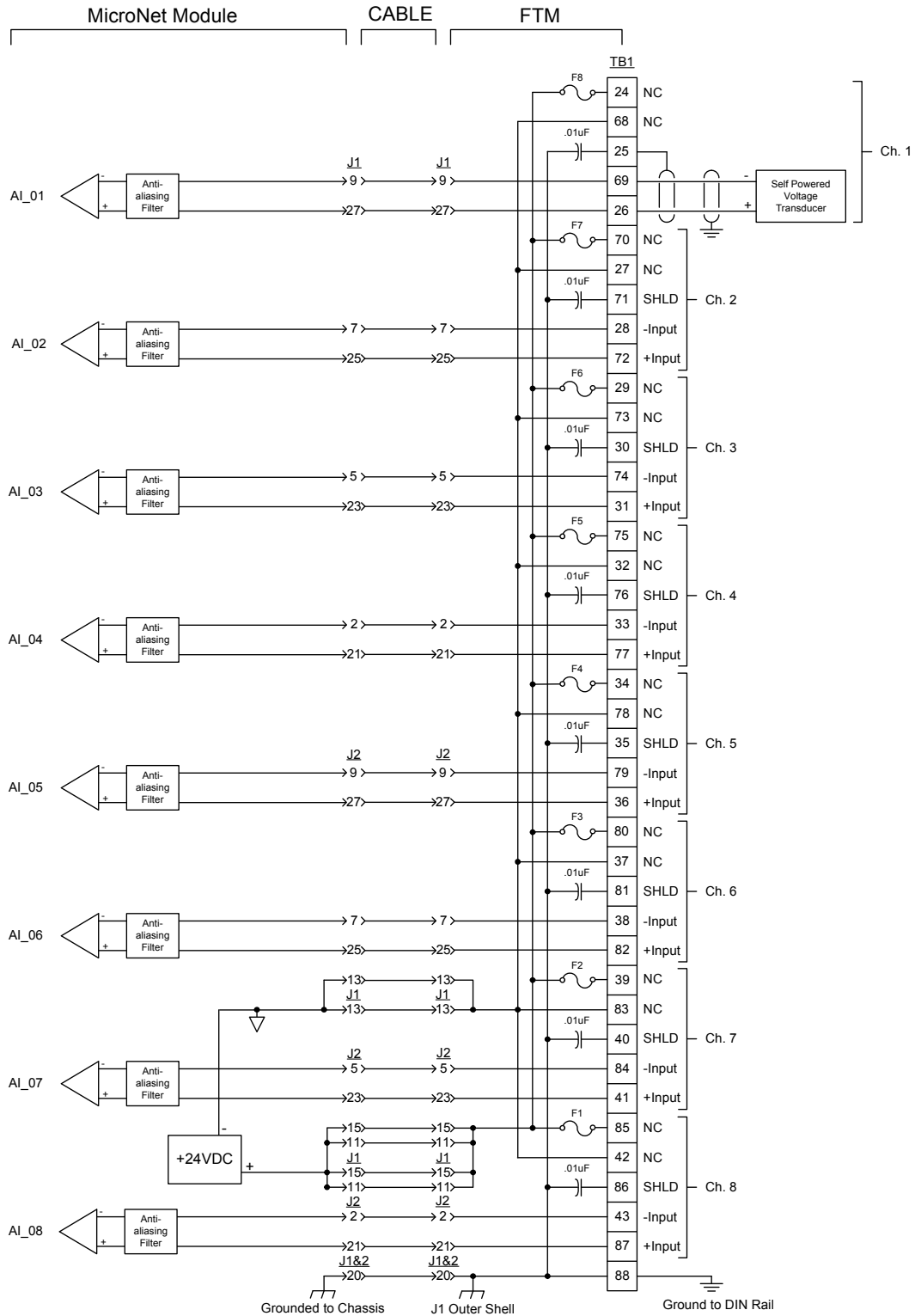

Figure 5-10. Voltage Input Wiring for an Analog Combo Module FTM (Simplex)

Analog Outputs

The analog outputs are 4–20 mA with a full-scale range of 0–25 mA. Each output monitors the output source current for fault detection. All of the analog outputs may be individually disabled. When a channel fault or a module fault is detected, the application program may annunciate the fault, disable the channel or module, and stop using the data in system calculations or control.

The Analog Combo module has four 4–20 mA current output drivers. All analog outputs can drive a maximum load of 600 ohms (load + wire resistance). Care should be taken to prevent ground loops and other faults when interfacing to non-isolated devices. See Figure 8-19 for an example of 4–20 mA output wiring.

Actuator Outputs

The actuator outputs may be configured for 4–20 mA or 20–160 mA. Configuration is done through the application software; no hardware modifications in the forms of jumpers or switches are necessary. For fault detection, each output monitors the output source current and the output return current. All of the actuator outputs may be individually disabled. When a channel fault or a module fault is detected, the application program may annunciate the fault, disable the channel or module, and stop using the data in system calculations or control.

Dither may be provided in the application software for each output. Dither is a low frequency (25 Hz) signal consisting of a 5-millisecond pulse modulated onto the DC actuator-drive current to reduce sticking due to friction in linear type actuators. Woodward TM-type actuators typically require dither. Dither amplitude is variable through the application software. See Figure 8-19 for an example of actuator wiring.

IMPORTANT

For a dual coil actuator, two actuator driver outputs must be used.

Configuration Notes

- Maximum impedance for a 4 to 20 mA actuator output driver is 360 ohms (actuator impedance + wire resistance).
- Maximum impedance for a 20 to 160 mA actuator output is 45 ohms (actuator impedance + wire resistance).
- Each actuator driver senses its source and return current to allow overcurrent and undercurrent alarms and shutdowns.

5.2.4—FTM Reference

See Volume 2, Chapter 12 for complete Analog Combo FTM field wiring information. See Appendix A for proper Module, FTM, and cable part numbers.

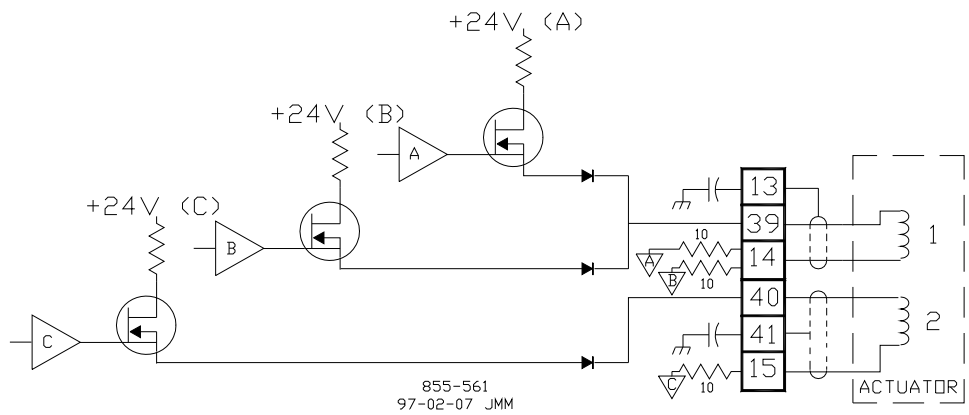
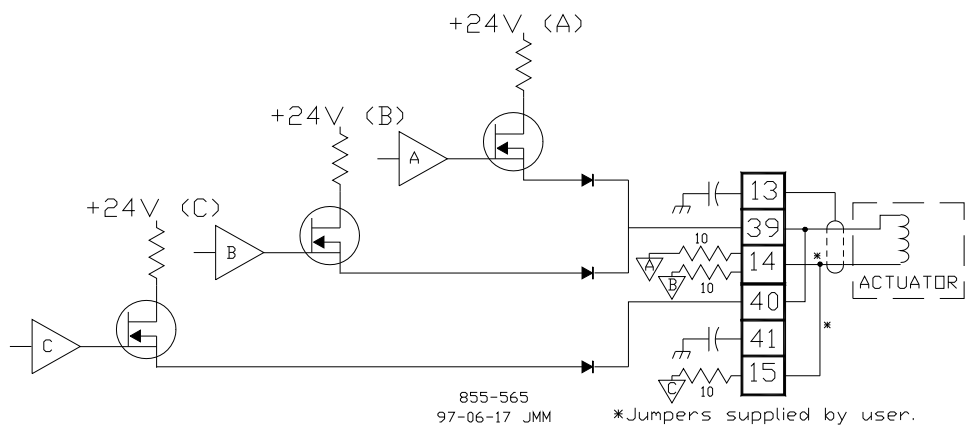
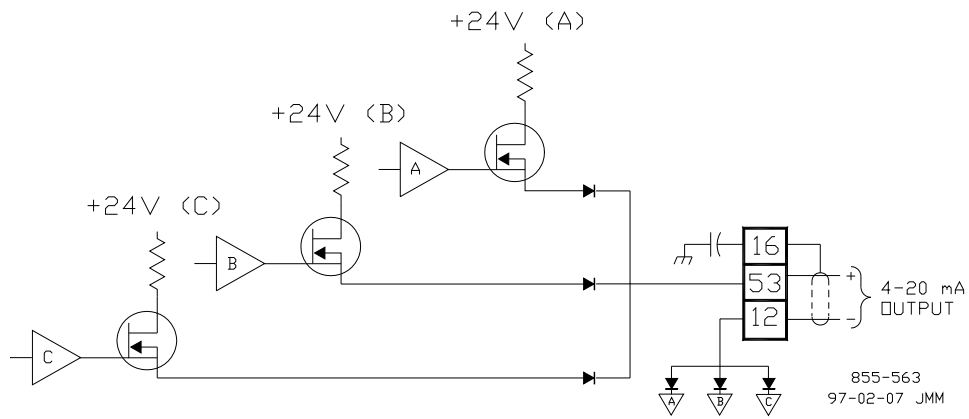

Figure 5-11. Analog Output and Actuator Wiring for an Analog Combo FTM

5.2.5—Troubleshooting

5.2.5.1. Fault Detection (Module Hardware)

Each Analog Combo module has a red Fault LED that is turned on when the system is reset. During initialization of a module, which occurs after every CPU reset, the CPU turns the Fault LED on. The CPU then tests the module using diagnostic routines built into the software. If the diagnostic test is not passed, the LED remains on or blinks. If the test is successful, the LED goes off. If the Fault LED on a module is illuminated after the diagnostics and initialization have been completed, the Analog Combo module may be faulty or may be located in the wrong slot.

Table 5-2. LED Indications of Failure

Number of LED Flashes	Failure
1	Hardware watchdog, CPU clock failure, reset fail
2	Micro-controller internal RAM test failure
3	External RAM test failure
4	Unexpected exception error
5	Dual Port RAM test failure
6	EEPROM failure
7	Communications watchdog time out

5.2.5.2. Fault Detection (I/O)

In addition to detecting module hardware faults, the application program may detect I/O faults.

Analog Input Faults. The application software may set a high and low latch setpoint to detect input faults.

Speed Sensor Input Faults. The application software may set a high and low latch setpoint to detect input faults. The low latch setpoint must be greater than one fiftieth of the frequency range.

Analog Output Driver Faults. The module monitors the source currents and annunciates faults. The application determines the course of action in the event of a fault.

Actuator Driver or Load Faults. The module monitors the source, returns currents, and annunciates faults. The application determines the course of action in the event of a fault.

Micro-controller Faults. The system monitors a software watchdog, a hardware watchdog, and a software watchdog on the VME bus communications. All outputs are shutdown in the event of a microcontroller fault.

Troubleshooting Guide

If during normal control operation, all of a chassis' TMR Analog Combo I/O modules have Fault LEDs on, check the kernel's CPU module for a failure. If during normal control operation only the MPU and Analog I/O module's Fault LED is on or flashing, insure that it is installed in the correct slot. If it is, then replace that MPU and Analog I/O module. See instructions for replacing the module in Chapter 14, Installation and Replacement Procedures. When a module fault is detected, its outputs should be disabled or de-energized.

Speed Sensor Inputs

MPUs: If a speed sensor input is not functioning properly, verify the following:

- Check that the cable is shielded and the shield is properly grounded per the Shields and Grounding section in Chapter 14, Installation and Replacement Procedures.
- Measure the input voltage on the terminal block. It should be in the range of 1-25 VRMS.
- Verify that the signal waveform is clean and void of double zero crossings.
- Verify that no ground connection exists and that the resulting 60 Hz signal is absent.
- Measure the frequency. It should be in the range of 100 Hz - 25 kHz.

- Look at the individual inputs into each kernel. A and B should read an input, and C should also read this input if the terminal block jumpers are installed. The application software should contain three separate numbers, one from each module. The numbers should be within 0.1% of each other, except kernel C if the jumpers are not installed.
- Verify that any unused MPU/Prox inputs are jumpered per Figures 8-15 and 8-16.

**CAUTION**

The following actions may shut down the prime mover. If all of the MPU and Analog I/O modules are reading approximately the same number, but it is not the right reading, go to step 1. If two of the MPU and Analog I/O modules are reading correctly, but one is reading incorrectly, go to step 2.

- Check the wiring. If the inputs are reading 0, look for a loose connection on the terminal blocks or disconnected or misconnected cables. Check the application software configuration to ensure that the input is configured properly. If the connections and application software are verified and the correct voltage is present on the terminal block, but all of the MPU and Analog I/O modules are reading 0 V (with a meter), exchange FTM #1 with FTM #2. See instructions for replacing the FTM in Chapter 14, Installation and Replacement Procedures. If the problem follows the FTM, replace the FTM. The FTM contains only traces and a few discrete components, so failure is extremely unlikely.
- If one or two of the MPU and Analog I/O modules are reading the correct number, but the other module(s) is (are) incorrect, check the application software configuration of the modules with the non-working channels. Also check to ensure that the cables are connected properly. If C kernel is not working, but A and B are, check to insure that the terminal block jumpers are installed and if the MPU can drive three inputs. If the reading is still incorrect, but the other readings from the MPU and Analog I/O module are correct, remove the MPU and Analog I/O module and exchange the J1 and J2 cables. See instructions for replacing the module in Chapter 14, Installation and Replacement Procedures. If the problem moves to a different channel, replace the cable. If not, replace the MPU and Analog I/O module. If the readings are incorrect on several channels of the same MPU and Analog I/O module, corresponding to both cables, replace the MPU and Analog I/O module.

Proximity Probes

If a speed sensor input is not functioning properly, verify the following:

- Check that the cable is shielded and the shield is properly grounded per the Shields and Grounding section in Chapter 14, Installation and Replacement Procedures.
- Measure the input voltage on the terminal block. It should be in the range of 3.5 - 32 Vpeak.
- Verify that the signal waveform is clean and void of double zero crossings.
- Verify that no ground connection exists and that the resulting 60 Hz signal is absent.
- Measure the frequency. It should be in the range of 0.5 Hz, to 25 kHz.
- Verify that any unused MPU inputs are jumpered per Figure 8-15.
- Check the wiring. Look for a loose connection at the terminal blocks, disconnected or misconnected cables, a missing jumper on the terminal block, or a blown fuse on the 24 Vdc on the FTM. See Figure 8-20 or 8-21 for FTM fuse locations.
- Check the software configuration to ensure that the input is configured properly.
- Check the fuse on the FTM. See the instructions and fuse locations below.
- If the other channels on the MPU and Analog I/O module are also not working, check the fuse on the MPU and Analog I/O module. This fuse is visible and can be changed through the bottom of the module. If the fuse is blown, fix the wiring problem and replace the fuse with another fuse of the same type and rating.
- Look at the individual inputs into each kernel. Each module reads the same input from the FTM, so the software should contain three separate numbers, one from each MPU and Analog I/O module. The numbers should be within 0.1% of each other unless a high common mode voltage is present.

 **CAUTION**

The following actions may shut down the prime mover. If all of the MPU and Analog I/O modules are reading approximately the same number, but it is not the right reading, go to step 1. If two of the modules are reading correctly, but one is reading incorrectly, go to step 2.

- Check the wiring. If the inputs are reading zero, look for a loose connection on the terminal blocks, disconnected or misconnected cables, a missing jumper on the terminal block, or a blown fuse on the 24 Vdc on the FTM. See instructions for replacing the fuse, below. Check the MPU and Analog I/O module fuse. See instructions for replacing the module in Chapter 14, Installation and Replacement Procedures. This fuse is visible and can be changed through the bottom of the module. If the fuse is blown, fix the wiring problem, then replace the fuse with another fuse of the same type and rating. Check the application software configuration to ensure that the input is configured properly. If the connections and application software are verified and the correct voltage is present on the terminal block, but all of the MPU and Analog I/O modules are reading 0 V (with a meter), exchange FTM #1 with FTM #2. See instructions for replacing the FTM in Chapter 14, Installation and Replacement Procedures. If the problem follows the FTM, replace the FTM. The FTM contains only a wire wound 3 W resistor and traces, so failure is extremely unlikely.
- If one or two of the MPU and Analog I/O modules are reading the correct number, but the other module(s) is (are) incorrect, check the application software configuration of the modules with the non-working channels, and check to ensure that the cables are connected properly. If the other channels on the same MPU and Analog I/O module are also not working, check the fuse on the MPU and Analog I/O module. See the instructions for replacing the module in Chapter 14, Installation and Replacement Procedures. This fuse is visible and can be changed through the bottom of the module. If this fuse is blown, fix the wiring problem and replace the fuse with a fuse of the same type and rating. If the reading is still incorrect, but the other readings from the MPU and Analog I/O module are correct, remove the MPU and Analog I/O module and exchange the J1 and J2 cables. If the problem moves to a different channel, replace the cable. If not, replace the MPU and Analog I/O module. If the readings are incorrect on several channels of the MPU and Analog I/O module, corresponding to both cables, replace the MPU and Analog I/O module.

Analog Inputs

If an analog input is not functioning properly, verify the following:

- Check that the cable is shielded and the shield is properly grounded per the Shields and Grounding section in Chapter 14, Installation and Replacement Procedures.
- Measure the input voltage on the terminal block. It should be in the range of 0–5 V.
- Look at the individual inputs into each kernel. Each module reads the same input from the FTM, so the application software should contain three separate numbers, one from each MPU and Analog I/O module. The numbers should be within 0.1% of each other unless a high common mode voltage is present.
- Check the wiring. If the inputs are reading 0 or the engineering units that correspond to 0 mA, look for a loose connection on the terminal blocks, disconnected or misconnected cables, a missing jumper on the terminal block if the input is a current input, or a blown fuse on the 24 Vdc on the FTM. See Figure 8-20 or 8-21 for FTM fuse locations.
- If all of the inputs are reading high, check that the 24 Vdc is not connected across the input directly.
- Check the software configuration to ensure that the input is configured properly.
- Check the fuse on the FTM. See the instructions and fuse locations below.



The following actions may shut down the prime mover. If all of the MPU and Analog I/O modules are reading approximately the same number, but the reading is incorrect, go to step 1. If two of the MPU and Analog I/O modules are reading correctly, but one is reading incorrectly, go to step 2.

- Check the wiring. If the inputs are reading 0 or the engineering units that correspond to 0 mA, look for a loose connection on the terminal blocks, disconnected or misconnected cables, a missing jumper on the terminal block if the input is a loop powered current input, or a blown fuse on the 24 Vdc on the FTM. See instructions for replacing the fuses on the FTM, below. If all of the inputs are reading high, check to ensure that the 24 Vdc is not connected across the input directly. Check the MPU and Analog I/O module fuse. See instructions for replacing the module in Chapter 14, Installation and Replacement Procedures. This fuse is visible and can be changed through the bottom of the module. If the fuse is blown, fix the wiring problem, then replace the fuse with another fuse of the same type and rating. Check the application software configuration to ensure that the input is configured properly. If the connections and application software are verified and the correct voltage is present on the terminal block, but all of the MPU and Analog I/O modules are reading 0 V (with a meter), exchange FTM #1 with FTM #2. See instructions for replacing the FTM in Chapter 14, Installation and Replacement Procedures. If the problem follows the FTM, replace the FTM. The FTM contains only a wire wound 3 W resistor and traces, so failure is extremely unlikely.
- If one or two of the MPU and Analog I/O modules are reading the correct number, but the other module(s) is (are) incorrect, check the application software configuration of the modules with the non-working channels, and check to ensure that the cables are connected properly. If the other channels on the same MPU and Analog I/O module are not working either, check the fuse on the MPU and Analog I/O module. See instructions for replacing the module in Chapter 14, Installation and Replacement Procedures. This fuse is visible and can be changed through the bottom of the module. If this fuse is blown, fix the wiring problem and replace the fuse with a fuse of the same type and rating. If the reading is still incorrect, but the other readings from the MPU and Analog I/O module are correct, remove the MPU and Analog I/O module and exchange the J1 and J2 cables. If the problem moves to a different channel, replace the cable. If not, replace the MPU and Analog I/O module. If the readings are incorrect on several channels of the MPU and Analog I/O module, corresponding to both cables, replace the MPU and Analog I/O module.

Analog Outputs

If an analog output is not functioning properly, verify the following:

- Check that the cable is shielded and the shield is properly grounded per the Shields and Grounding section in Chapter 14, Installation and Replacement Procedures.
- Check the load resistance to ensure that it is below 600 ohms.
- Check to ensure that the load wiring is isolated.
- Check the wiring for a loose connection on the terminal blocks and disconnected or misconnected cables.
- Disconnect the field wiring and connect a resistor across the output. If the output is correct across the resistor, there is a problem with the field wiring.
- If the other output channels on the MPU and Analog I/O module are also not working, check the fuse on the MPU and Analog I/O module. See instructions for module replacement in Chapter 14, Installation and Replacement Procedures. This fuse is visible and can be changed through the bottom of the module. If the fuse is blown, fix the wiring problem and replace the fuse with a fuse of the same type and rating.
- Check the software configuration to ensure that the output is configured properly.

 **CAUTION**

The following actions may shut down the prime mover. Disconnect the field wiring and connect a resistor across the output. If the output current is 0 mA, go to step 1. If the output current is correct, but some of the outputs have a fault, go to step 2.

- Check the wiring for a loose connection on the terminal blocks or disconnected or misconnected cables. If none of the outputs on a given MPU and Analog I/O module are functioning, check the MPU and Analog I/O module fuse. See instructions for replacing the module in Chapter 14, Installation and Replacement Procedures. This fuse is visible and can be changed through the bottom of the module. If the fuse is blown, fix the wiring problem, then replace the fuse with another fuse of the same type and rating. Check the application software configuration to ensure that the output is configured properly. If the connections and application software are verified, exchange FTM #1 with FTM #2. See instructions for replacing the FTM in Chapter 14, Installation and Replacement Procedures. If the problem follows the FTM, replace the FTM. The FTM contains only traces and a few discrete components, so failure is extremely unlikely.
- If one or two of the MPU and Analog I/O modules have an output fault, but the other module(s) does (do) not, check the application software, and check to ensure that the cables are connected properly. If the other output channels on the same MPU and Analog I/O module are also not working, check the fuse on the MPU and Analog I/O module. See instructions for replacing the module in Chapter 14, Installation and Replacement Procedures. This fuse is visible and can be changed through the bottom of the module. If the fuse is blown, fix the wiring problem and replace the fuse with a fuse of the same type and rating. If the output still has a fault, but the other output channels on the MPU and Analog I/O module are functioning properly, remove the MPU and Analog I/O module and exchange the J1 and J2 cables. If the problem moves to a different channel, replace the cable. If not, replace the MPU and Analog I/O module. If the readings are incorrect on several channels of the MPU and Analog I/O module, corresponding to both cables, replace the same MPU and Analog I/O module.

Actuator Outputs

If an actuator output is not functioning properly, verify the following:

- Check that the cable is shielded and the shield is properly grounded per the Shields and Grounding section in Chapter 14, Installation and Replacement Procedures.
- Check the load resistance to ensure that it is below the specified limit.
- Check to ensure that the load wiring is isolated.
- Check the wiring for a loose connection on the terminal blocks or disconnected or misconnected cables.
- Disconnect the field wiring and connect a resistor across the output.
- If the other output channels on the MPU and Analog I/O module are also not working, check the fuse on the MPU and Analog I/O module. See instructions for module replacement in Chapter 14, Installation and Replacement Procedures. This fuse is visible and can be changed through the bottom of the module. If the fuse is blown, fix the wiring problem, and replace the fuse with a fuse of the same type and rating.
- Check the software configuration to ensure that the output is configured properly

 **CAUTION**

The following actions may shut down the prime mover. Disconnect the field wiring and connect a resistor across the output; if the output current is 0 mA, go to step 1. If the output current is correct, but some of the outputs have a fault, go to step 2.

- Check the wiring for a loose connection on the terminal blocks, or disconnected or misconnected cables. If none of the outputs on a given MPU and Analog I/O module are functioning, check the MPU and Analog I/O module fuse. See instructions for replacing the module in Chapter 14, Installation and Replacement Procedures. This fuse is visible and can be changed through the bottom of the module. If the fuse is blown, fix the wiring problem, then replace the fuse with another fuse of the same type and rating. Check the application software configuration to ensure that the output is configured properly. If the connections and application software are verified, exchange FTM #1 with FTM #2. See instructions for replacing the FTM in Chapter 14, Installation and Replacement Procedures. If the problem follows the FTM, replace the FTM. The FTM contains only traces and a few discrete components, so failure is extremely unlikely.
- If one or two of the MPU and Analog I/O modules have an output fault, but the other module(s) does (do) not, check the application software configuration, and check to ensure that the cables are connected properly. Check the wiring for dual coil and single coil actuators, and ensure that the wiring configuration matches the application software configuration. If the other output channels on the same MPU and Analog I/O module are also not working, check the fuse on the MPU and Analog I/O module. See instructions for replacing the module in Chapter 14, Installation and Replacement Procedures. This fuse is visible and can be changed through the bottom of the module. If this fuse is blown, fix the wiring problem and replace the fuse with a fuse of the same type and rating. If the output still has a fault, but the other output channels on the MPU and Analog I/O module are functioning properly, remove the MPU and Analog I/O module and exchange the J1 and J2 cables. If the problem moves to the other channel, replace the cable. If not, replace the MPU and Analog I/O module. If the readings are incorrect on several channels of the same MPU and Analog I/O module, corresponding to both cables, replace the MPU and Analog I/O module.

5.2.5.4. Replacing a Fuse on the Field Terminal Module (FTM)

1. Verify that the condition that caused the fuse to blow has been corrected.

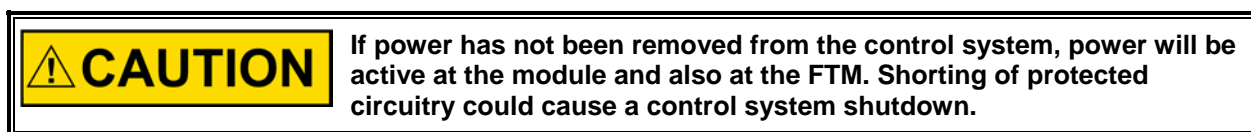

2. Remove FTM cover carefully, to prevent contact with any FTM circuitry under the cover. To remove the FTM cover, pinch the retaining barbs and lift the cover.
3. Locate and replace the fuse with another fuse of the same size and rating. See Figure 5-12 or 5-13 for channel fuse locations.
4. Replace the FTM cover.

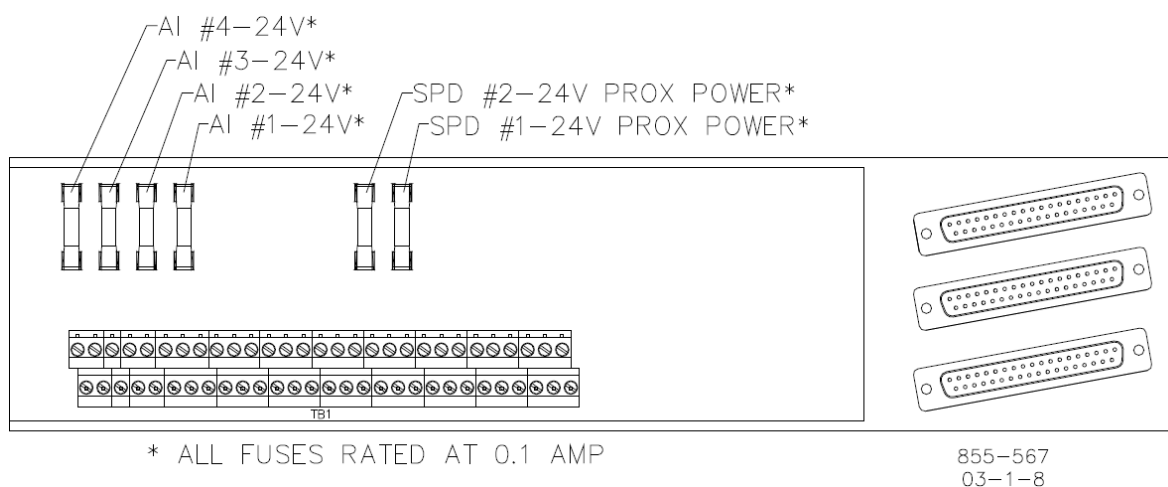

Figure 5-12. TMR MPU and Analog I/O Module FTM Fuse Locations

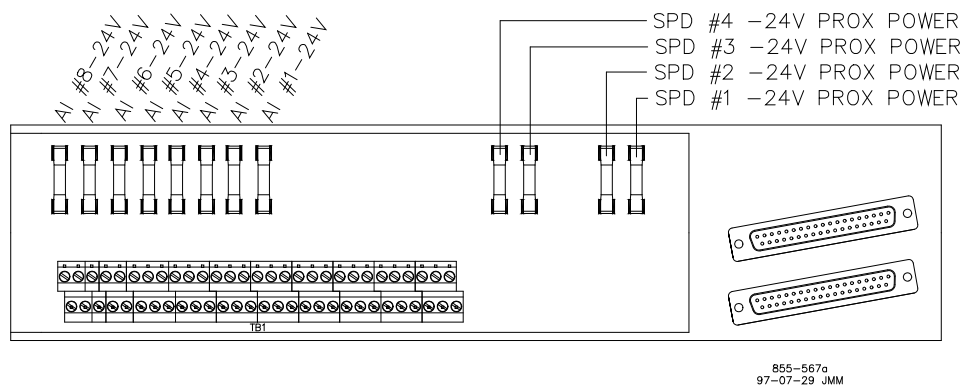

Figure 5-13. Simplex MPU and Analog I/O Module FTM Fuse Locations

5.3. 24/8 Analog Module

5.3.1—Module Description

A 24/8 Analog module contains circuitry for twenty-four analog inputs and eight 4–20 mA outputs. These modules have no potentiometers and require no calibration. A module may be replaced with another module of the same part number without any adjustment.

The 24/8 Analog Modules come in four different configurations.

1. 24 channels of 4–20 mA inputs with 8 channels of 4–20 mA outputs (2-pole 10 ms filter on all input channels).
2. 24 channels of 4–20 mA inputs with 8 channels of 4–20 mA outputs (2-pole 10 ms filter on all input channels, except channels 23 and 24, which have 2-pole 5 ms filter).
3. 12 channels of 4–20 mA inputs, 12 channels 0–5 Vdc inputs with 8 channels of 4–20 mA outputs (2-pole 10 ms filter on all input channels).

All 4–20 mA analog inputs may be used with two-wire ungrounded (loop powered) transducers or isolated (self-powered) transducers. All analog inputs have 200 Vdc of common mode rejection. If interfacing to a non-isolated device, which may have the potential of reaching over 200 Vdc with respect to the control's common, the use of a loop isolator is recommended to break any return current paths producing erroneous readings.

Each board has an on-board processor for automatic calibration of the I/O channels. Each analog input incorporates a time-stamping feature with 5 ms resolution for two low setpoints and two high setpoints.



Figure 5-14. 24/8 Analog Module

5.3.2—Module Specification

5.3.2.1. Analog Input Ratings

Number of channels:	24
Update time:	5 ms
Input range:	0–25 mA or 0–5 V; software and hardware selectable

IMPORTANT

The maximum voltage input range may vary between 4.975 and 5.025 Volts from module to module.

Isolation:	0 Vrms, 60 dB CMRR, 200 Vdc common mode rejection voltage; no galvanic isolation
Input imp. (4–20 mA):	200 ohms
Anti-aliasing filter:	2 poles at 10 ms
Resolution:	16 bits
Accuracy:	Software calibrated to 0.1%, over 0–25 mA full scale
Temp drift:	275 ppm/C, maximum
Fuse:	100 mA fuse per channel.

Time stamping: 5 ms resolution on low event and latch, and high event and latch

IMPORTANT

The 24 channel analog inputs are divided into two banks, with channel 1 through channel 12 data gathering at 1.8 ms after the MFT tick and channel 13 through channel 24 data gathering at 3.7 ms after the MFT tick.

5.3.2.2. 4–20 mA Output Ratings

Number of channels:	8
Update time:	5 ms
Output Driver:	Pulse Width Modulated (PWM)
PWM frequency:	6.14 kHz
Filter:	3 poles at 500 ms

Current output:	4–20 mA
Current output range:	0–25 mA
Isolation:	0 Vrms
Max load resistance:	600 ohms (load + wire resistance)
Current readback:	8 bits
Readback isolation:	60 dB CMRR, 200 Vdc common mode rejection voltage
Resolution:	11 bits
Accuracy:	Software calibrated to 0.2% of 0–25 mA full scale
Temperature drift:	125 ppm/C, maximum
Readback accuracy:	0.5% of 0–25 mA full scale
Readback temp drift:	400 ppm/C, maximum

5.3.3—Installation

The modules slide into card guides in the control's chassis and plug into the motherboard. The modules are held in place by two screws, one at the top and one at the bottom of the front panel. Also at the top and bottom of the module are two handles which, when toggled (pushed outward), move the modules out just far enough for the boards to disengage the motherboard connectors.

Each 24/8 Analog Module is connected through two High Density Analog/Discrete cables to two 24/8 Analog FTMs. All I/Os on the module are accessible on the FTM, and the channels are labeled to correspond to their software locations (e.g., analog input 1 on the FTM will be analog input 1 in the application software). See Figure 8-23 for an example.

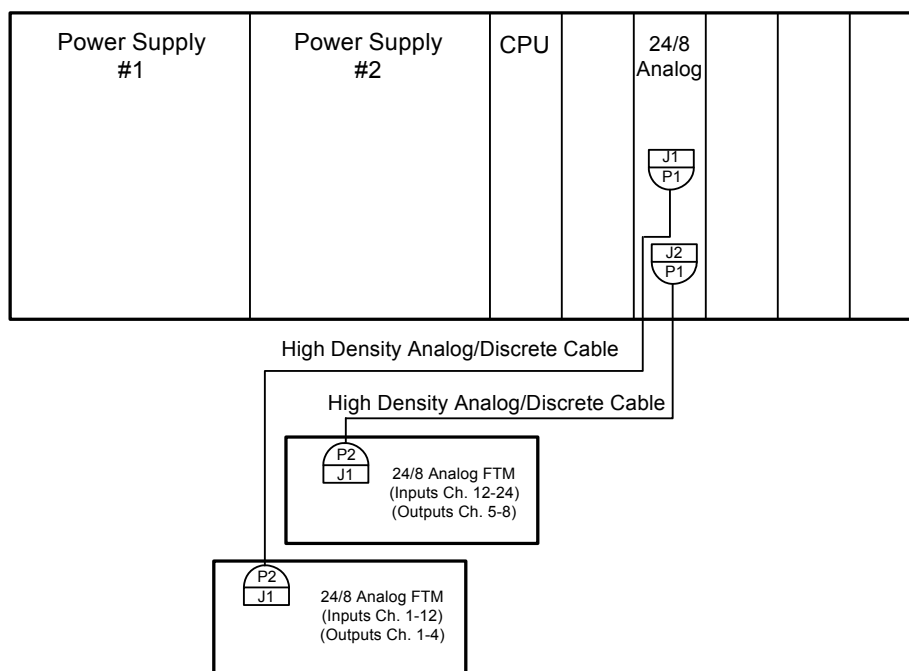

Figure 5-15. Simplex System Configuration Example

Analog Inputs

For a 4–20 mA input signal, the 24/8 Analog Module uses a 200 ohm resistor across the input located on the 24/8 Analog Module. Each analog input channel may power its own 4–20 mA transducer. See Figure 8-24 for analog input connection. This power is protected with a 100 mA fuse on each channel to prevent an inadvertent short from damaging the module. The 24 Vdc outputs are capable of providing 24 Vdc with $\pm 10\%$ regulation. The maximum current is 0.8 A. Power connections can be made through terminals located on the 24/8 Analog FTMs. See Chapter 12 for complete field wiring information for the 24/8 Analog FTM.

IMPORTANT When configuring the AI Combo block in GAP, set Conf. input field to 1 for all inputs when used with the 24/8 Analog FTM. This will allow the block to use the module factory calibration values for the 4–20 mA inputs that were calibrated with 200 ohm internal resistors on the 24/8 Analog Module.

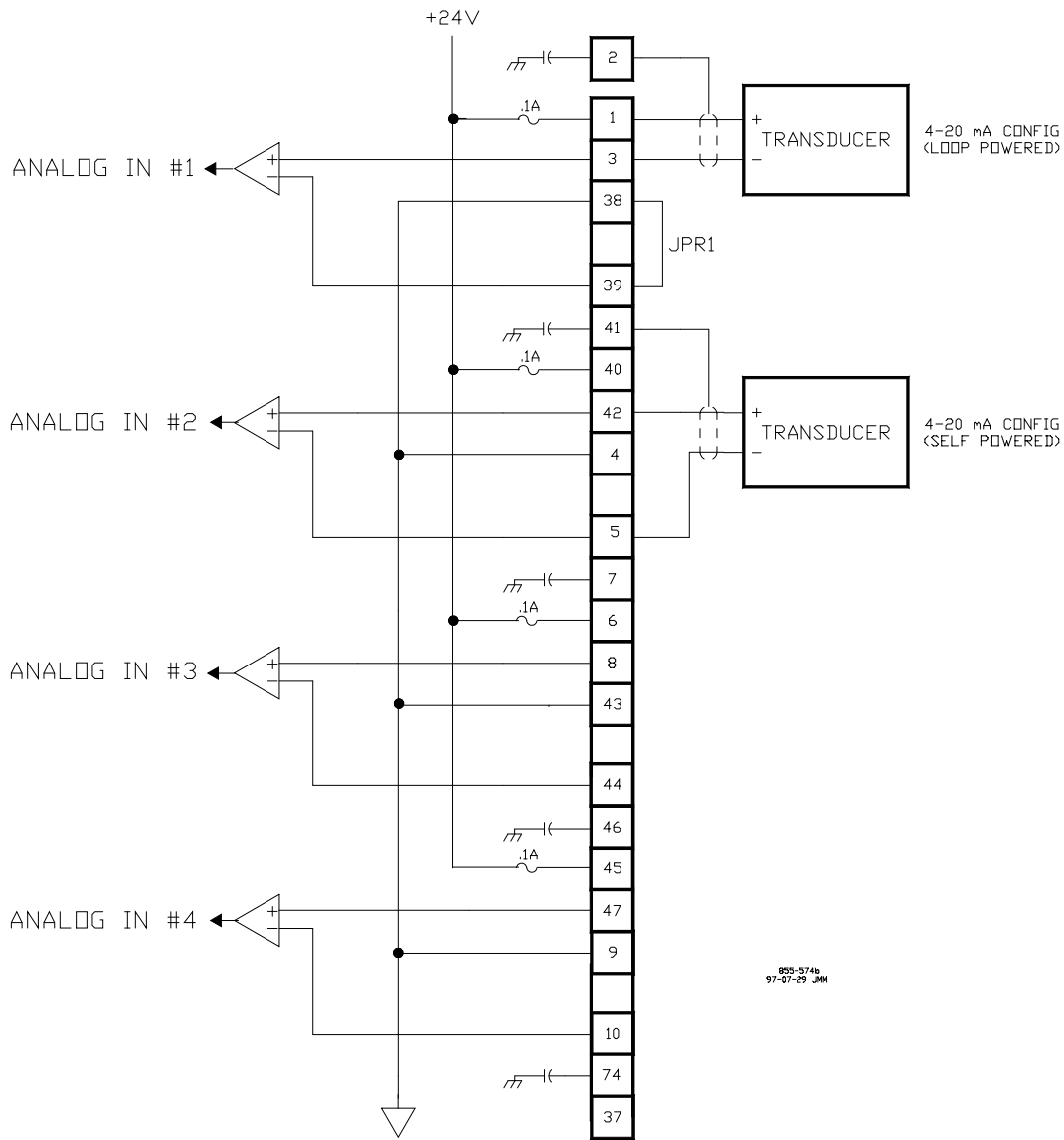

Figure 5-16. Analog Input Wiring for a 24/8 Analog FTM

Analog Outputs

There are eight analog output channels of 4–20 mA with a full-scale range of 0–25 mA. All Analog Outputs can drive a maximum load of 600 ohms (load + wire resistance). See Figure 8-25 for analog output connection. Each output monitors the output source current for fault detection. All of the analog outputs may be individually disabled. When a channel fault or a module fault is detected, the application program may annunciate the fault, disable the channel and stop using data in system calculations or control. Care should be taken to prevent ground loops and other faults when interfacing to non-isolated devices. See Chapter 12 for complete field wiring information for the Analog High Density FTM.

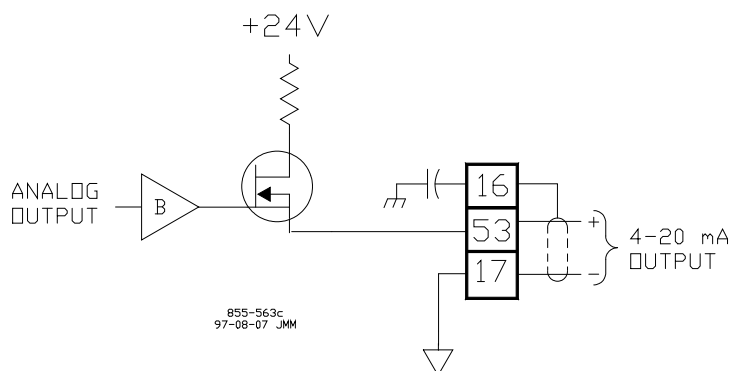

Figure 5-17. Analog Output Wiring for a 24/8 Analog FTM

5.3.4—FTM Reference

See Chapter 12 for complete field wiring information for the Analog High Density FTM. See Appendix A for part number Cross Reference for modules, FTMs, and cables.

5.3.5—Troubleshooting

Each 24/8 Analog module has a red Fault LED that is turned on when the system is reset. During initialization of a module, which occurs after every CPU reset, the CPU turns the Fault LED on. The CPU then tests each module using diagnostic routines built into the software. If the diagnostic test is not passed, the LED remains on or blinks. If the test is successful, the LED goes off. If the Fault LED on a module is illuminated after the diagnostics and initialization have been run, the module may be faulty or may be located in the wrong slot.

Table 5-3. LED Indications of Failure

Number of LED Flashes	Failure
1	Hardware watchdog, CPU clock failure, reset fail
2	Micro-controller internal RAM test failure
3	External RAM test failure
4	Unexpected exception error
5	Dual Port RAM test failure
6	EEPROM failure
7	Communications watchdog time out
8	EEPROM error is corrected (reset the module to continue)
9	Missing an A/D Converter interrupt

5.3.5.1. Fault Detection (I/O)

In addition to detecting the High Density Analog I/O module hardware faults, the application software may detect I/O faults.

Analog Input Faults: The application software may be set with a high and low latch setpoint to detect input faults.

Analog Output Driver Faults: The module monitors the source currents and annunciates faults. The application software determines the course of action in the event of a fault.

Microcontroller Faults: The system monitors a software watchdog, a hardware watchdog, and a software watchdog on the VME bus communications. All outputs are shut down in the event of a microcontroller fault.

Troubleshooting Guide

If during normal control operation, all of the 24/8 Analog modules have Fault LEDs on, check the chassis' CPU module for a failure. If during normal control operation only the 24/8 Analog module's Fault LED is on or flashing, insure that it is installed in the correct slot. If it is, then replace that module. See instructions for replacement in Chapter 15. When a module fault is detected, its outputs will be disabled or de-energized.

Analog Inputs

If an analog input is not functioning properly, verify the following:

1. Check that the cable is shielded and the shield is properly grounded per the Shields and Grounding section in Chapter 14.
2. Measure the input voltage on the FTM terminal block. It should be in the range of 0–5 V.
3. Verify that there are no or minimal AC components to the Analog Input signal. Improper shielding may introduce AC noise on the input terminals.
4. Check the wiring. If the inputs are reading 0 or the engineering units that correspond to 0 mA, look for a loose connection on the terminal blocks, disconnected or misconnected cables, a missing jumper on the terminal block if the input is a current input, or a blown fuse on the 24 Vdc on the FTM.
5. If all of the inputs are reading high, check that the 24 Vdc is not connected across the input directly.
6. Check the software configuration to ensure that the input is configured properly.
7. If all of the channels on the 24/8 Analog module are not working, check the fuse on the 24/8 Analog module. See instructions for module replacement in Chapter 15. This fuse is visible and can be changed through the bottom of the module. If the fuse is blown, fix the wiring problem, then replace the fuse with another fuse of the same type and rating.
8. After verifying all of the above, exchange the J1 and J2 cables. If the problem moves to a different channel, replace the cable. If not, replace the module.
9. If the readings are incorrect on several channels of the 24/8 Analog module, corresponding to both cables, replace the module.
10. If replacing the module does not fix the problem, replace the FTM. The FTM contains only traces and a few discrete components, so failure is extremely unlikely. See instructions for replacing the FTM in Chapter 15.

Analog Outputs

If an analog output is not functioning properly, verify the following:

1. Check that the cable is shielded and the shield is properly grounded per the Shields and Grounding section in Chapter 14.
2. Check the load resistance to ensure that it is not greater than 600 ohms.
3. Check to ensure that the load wiring is isolated.
4. Check the wiring for a loose connection on the FTM terminal blocks and disconnected or misconnected cables.
5. Disconnect the field wiring and connect a resistor across the output. If the output is correct across the resistor, there is a problem with the field wiring.
6. If all of the channels on the 24/8 Analog module are not working, check the fuse on the 24/8 Analog module. See instructions for module replacement in Chapter 15. This fuse is visible and can be changed through the bottom of the module. If the fuse is blown, fix the wiring problem, then replace the fuse with another fuse of the same type and rating.

7. Check the software configuration to ensure that the output is configured properly.
8. After verifying all of the above, exchange the J1 and J2 cables. If the problem moves to a different channel, replace the cable. If not, replace the module.
9. If the readings are incorrect on several channels of the module, corresponding to both cables, replace the module.
10. If replacing the module does not fix the problem, replace the FTM. The FTM contains only traces and a few discrete components, so failure is extremely unlikely. See instructions for replacing the FTM in Chapter 15.

5.4. Dataforth 24/8 Analog Module

5.4.1—Module Description

The Dataforth Analog Module uses the same board as utilized in the 24/8 Analog Module in section 7.3. The module is configured for 24 channels of 0–5 Vdc inputs and 8 channels of 4–20 mA outputs. In place of the two standard 24/8 Analog FTMs, two special Simplex Dataforth FTMs are connected through two high density analog/digital cables. The Simplex Dataforth FTM is designed to convert sensor input signals to a 0 to 5 V input compatible with the 24/8 Analog module. Each channel is individually configurable via a plug-in standard isolated Dataforth SCM7B converter that has been modified to meet Woodward's bandwidth and input temperature range requirements. Each module can plug into any of the 12 channels on the FTM. Each plug-in module converts the incoming signal to a 1 to 4 volt signal. No Calibration is required on the FTM or its plug-in modules. The plug-in modules are powered directly through the cable connector; resulting in no need for external power connections to the FTM. These plug-in modules currently include 4–20 mA input (internal shunt resistor), 0–5 Vdc input (pass through), 100 Ω RTDs, 200 Ω RTDs, and Type K Thermocouples. For Analog Outputs no plug-in modules are required. Isolation is provided on each channel. Channels are labeled to correspond to their software locations (e.g., analog input 1 on the FTM corresponds to analog input 1 in the application software.)



Figure 5-18. Dataforth 24/8 Analog Module

5.4.2—Specifications

To obtain overall signal input accuracy and bandwidth, the Dataforth FTM (0–5 V) module input accuracy and the Dataforth 24/8 Analog Module must be taken into account.

Table 5-4. Module Accuracy

Module	K Type Thermocouple	RTD 100 Ω Pt European Curve	Pass Through with 200 Ω Resistor (0.1%, 3 Watt)	Pass Through
Dataforth P/N	SCM7B47K-1458	SCM7B34-1459	SCM7BPT-1460	SCM7BPT
Woodward P/N	1784-653	1784-655	1784-659	1784-657
Input Range	-70°F (-56.67°C) to +2200°F (+1204.44°C)	-70°F (-56.67°C) to +500°F (+260°C)	0 to 25 mA (Limited by MicroNet card input range.)	0 to 5 V (limited by MicroNet card input range.)
Input Protection Continuous	120 Vrms max	120 Vrms max	None	None
Input Protection Transient	ANSI/IEEE C37.90.1-1989	ANSI/IEEE C37.90.1-1989	None	None
Output Range	1 to +5 V Linearized	1 to +5 V Linearized	0 to 5 V**	0 to 5 V
Isolation (Input to Output)	1500 Vrms	1500 Vrms	None	None
CMRR (50 or 60 Hz)	100 dB	100 dB	N/A	N/A
Accuracy Maximum	$\pm 0.32\%$ of Span*	$\pm 0.075\%$ of Span*	N/A	N/A
Gain Stability (-40 to +85°C)	± 40 ppm/°C	± 60 ppm/°C	± 20 ppm/°C	N/A
Input Offset Stability	± 0.5 μ V/°C	± 1.0 μ V/°C	N/A	N/A
Output Offset Stability	$\pm 0.002\%$ Span/°C	$\pm 0.002\%$ Span/°C	N/A	N/A
Open Input Response	Upscale	N/A	N/A	N/A
Open Input Detection Time	10 s. max	N/A	N/A	N/A
Bandwidth (-3 dB)	150 Hz	150 Hz	N/A	N/A
Step Response (0 to 90%)	3 ms	3 ms	N/A	N/A
Supply Voltage	14-35 Vdc	14-35 Vdc	None	None
Supply Current	30 mA max	30 mA max	N/A	N/A
Supply Sensitivity	$\pm 0.0001\%/ \%$ Vs	$\pm 0.0001\%/ \%$ Vs	N/A	N/A
Operating Temp. Range	+5 to +45°C	-40 to +85°C	-40 to +85°C	-40 to +85°C
Storage Temp. Range	-40 to +85°C	-40 to +85°C	-40 to +85°C	-40 to +85°C
Relative Humidity	0 to 90% Non-condensing	0 to 90% Non-condensing	0 to 90% Non-condensing	0 to 90% Non-condensing
Sensor Excitation Current	N/A	250 μ A	N/A	N/A
Lead Resistance Effect	N/A	$\pm 0.02^\circ\text{C}/\Omega$ max	N/A	N/A

* Accuracy includes the effects of repeatability, hysteresis, and conformity. CJC sensor, thermocouple, or RTD sensor accuracy should be added to the module accuracy to compute the overall measurement accuracy.

** The maximum input voltage range may vary between 4.975 and 5.025 Volts from Dataforth module to Dataforth module.

Outputs can drive a maximum load of 600 ohms (load + wire resistance).

5.4.3—Installation

The modules slide into card guides in the control's chassis and plug into the motherboard. The modules are held in place by two screws, one at the top and one at the bottom of the front panel. Also at the top and bottom of the module are two handles which, when toggled (pushed outward), move the modules out just far enough for the boards to disengage the motherboard connectors.

Each Dataforth module is connected through two high density analog/discrete cables to two Simplex Dataforth FTMs. All I/Os on the module are accessible on the FTM. See Figure 5-19 for an example.

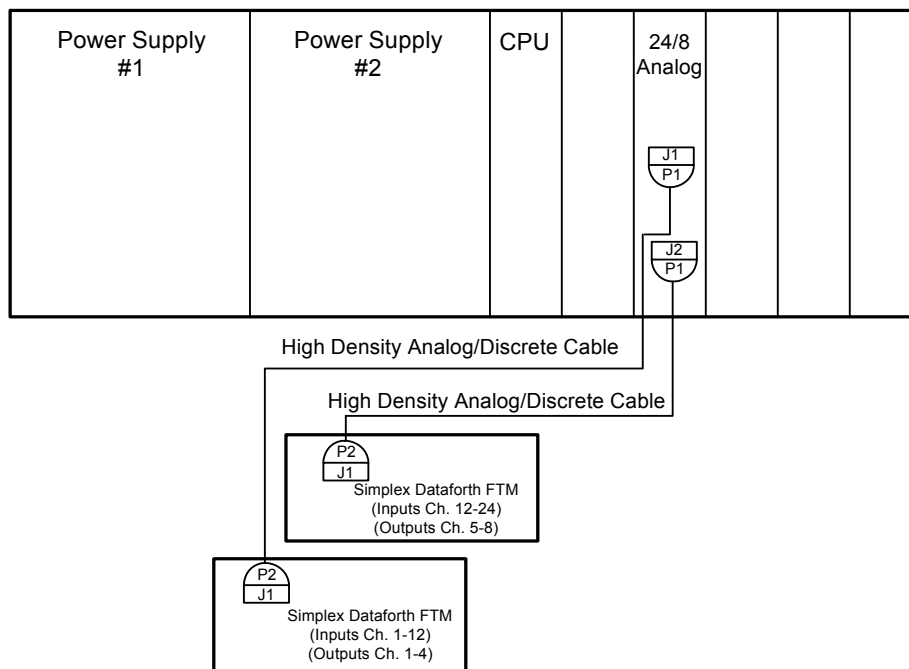

Figure 5-19. Simplex Dataforth Configuration Example

5.4.3.1. Field Wiring

See Chapter 12 for complete wiring connections for the Simplex Dataforth FTM. Each input channel requires a Dataforth plug-in module per input. Install one of the five different Dataforth modules into each of the 12 plug-in slots on the FTM. It is not necessary to have a plug-in module in a slot if not used. With the Simplex Dataforth FTM connected to J1 of the Dataforth Module, channels 1-12 will be active. With the Simplex Dataforth FTM connected to J2 of the Dataforth Module, channels 13-24 will be active. Wire each channel per the following examples for each type of plug-in module. Install jumpers on FTM module as shown for specific type of input.

5.4.3.2. Thermocouple Plug-in Module

The Thermocouple Plug-in module accepts a single input from a type K thermocouple. The signal is filtered, isolated, amplified, linearized, and converted to a 1 to +5 V analog voltage for output to the Dataforth Module.

Linearization is achieved by creating a non-linear transfer function through the module itself. This non-linear transfer function is configured at the factory, and is designed to be equal and opposite to the thermocouple non-linearity.

The cold junction compensation (CJC) is performed by using an NTC thermistor, externally mounted on the FTM module, as shown in Figure 5-20. The thermocouple signal will fail high if an open wire is detected.

These modules incorporate both Thompson (Bessel) and Butterworth five-pole filter to maximize both time and frequency response. After the initial field side filtering, the input signal is chopped by a proprietary chopper circuit and transferred across the transformer isolation barrier. The signal is then reconstructed and filtered and scaled for 1 to 5 V for the Dataforth Module.

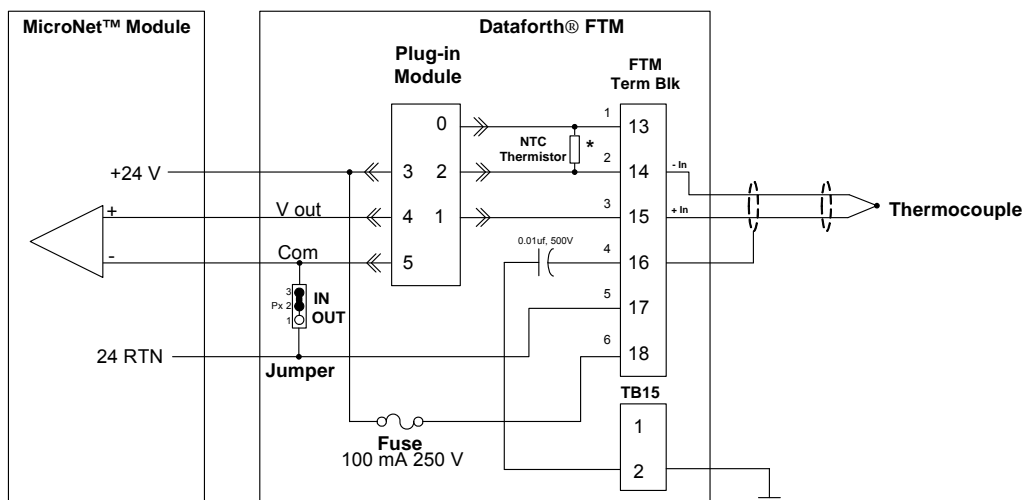

Figure 5-20. Thermocouple Wiring to Simplex Dataforth FTM

5.4.3.3. RTD Plug-in Module

The RTD Plug-in module accepts a single connection from a 100 or 200 Ohm Platinum RTD, depending on the selected RTD Plug-in module as shown in Figure 5-21. The input signal is filtered, isolated, amplified, linearized, and converted to a 1 to +5 V analog voltage for output to High Density Analog I/O Module.

These modules incorporate both Thompson (Bessel) and Butterworth five-pole filter to maximize both time and frequency response. After the initial field side filtering, the input signal is chopped by a proprietary chopper circuit and transferred across the transformer isolation barrier. The signal is then reconstructed and filtered and scaled for 1 to 5 V for the Dataforth Module.

Linearization is achieved by creating a non-linear transfer function through the module itself. This non-linear transfer function is configured at the factory, and is designed to be equal and opposite to the specific RTD non-linearity. Lead compensation is achieved by matching two current paths thus canceling the effects of lead resistance.

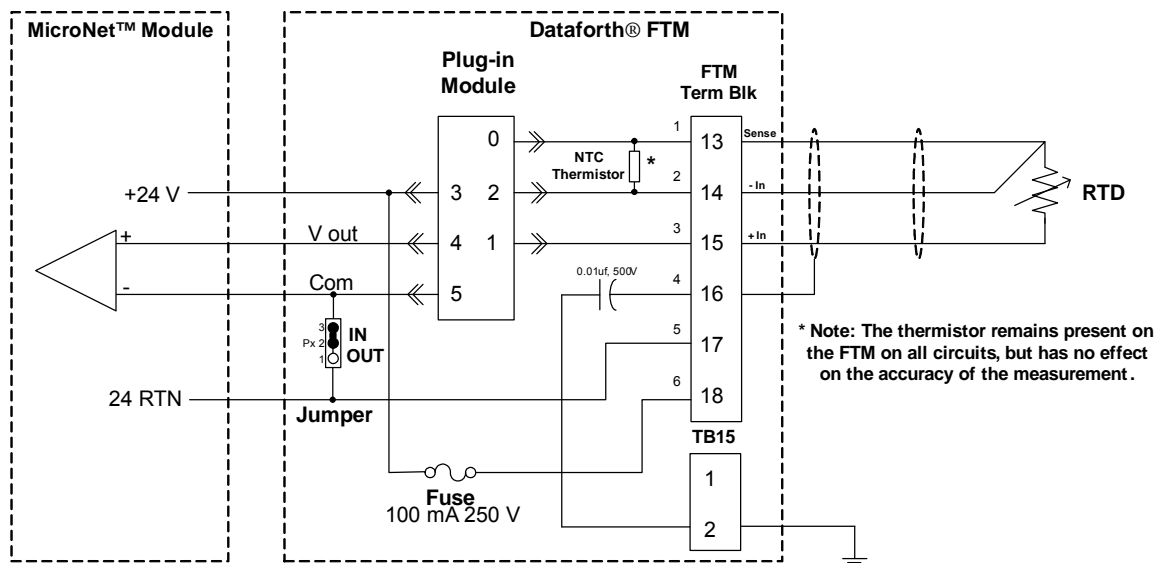

Figure 5-21. RTD Wiring to Simplex Dataforth FTM

5.4.3.4. Current Input Plug-in Module

The Current Input Plug-in Module is a pass-through module with a 200-ohm precision shunt resistor to convert the 4–20 mA input to 0.8 to 4 Vdc signal. No filtering is done on this module. See Figure 8-30 for an example of wiring a loop-powered transducer and Figure 5-23 for a self-powered transducer.

IMPORTANT

When configuring the AI Combo block in GAP, set Conf. input field to 2 for all 4–20 mA inputs when used with the current input plug-in module. This will allow the block to use the module factory voltage calibration values with a gain factor for a 200-ohm external resistor on the Dataforth FTM.

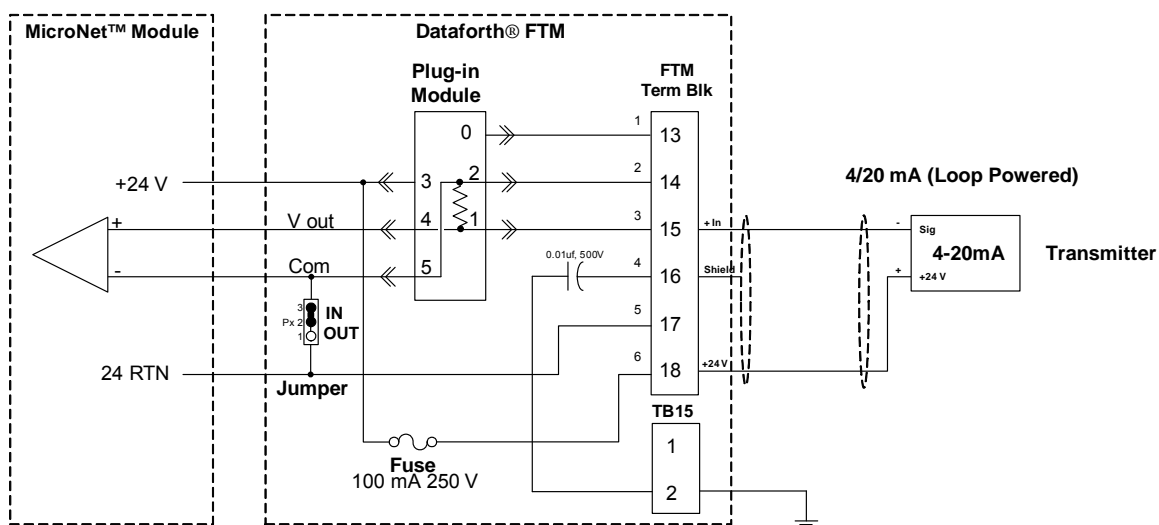

Figure 5-22. Loop powered 4–20 mA Signal Wiring to Simplex Dataforth FTM

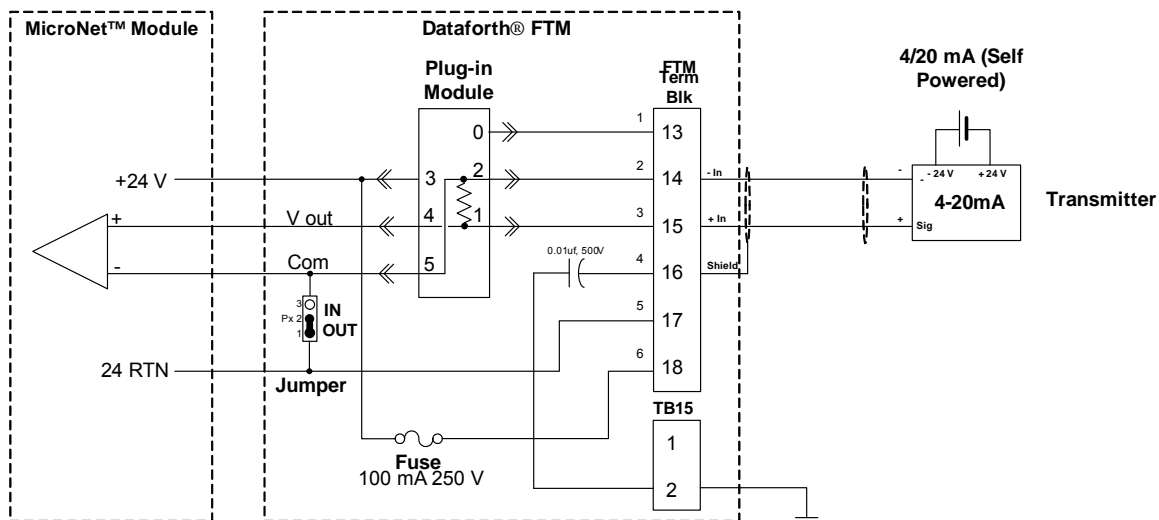

Figure 5-23. Self-powered 4–20 mA Signal Wiring to Simplex Dataforth FTM

5.4.3.5. Voltage Input Plug-in Module

The Voltage Input Module is a pass-through module and is capable of reading voltage signals between 0.8 and 4.8 Vdc. No filtering is provided by the Dataforth module. See section 24/8 Analog Module for filtering provided by the Dataforth Module. See Figure 5-24 for an example of wiring a voltage transducer.

IMPORTANT

When configuring the AI Combo block in GAP, set Conf. input field to 0 for all voltage inputs when used with the voltage input plug-in module. This will allow the block to use the module factory voltage calibration values with the Dataforth FTM.

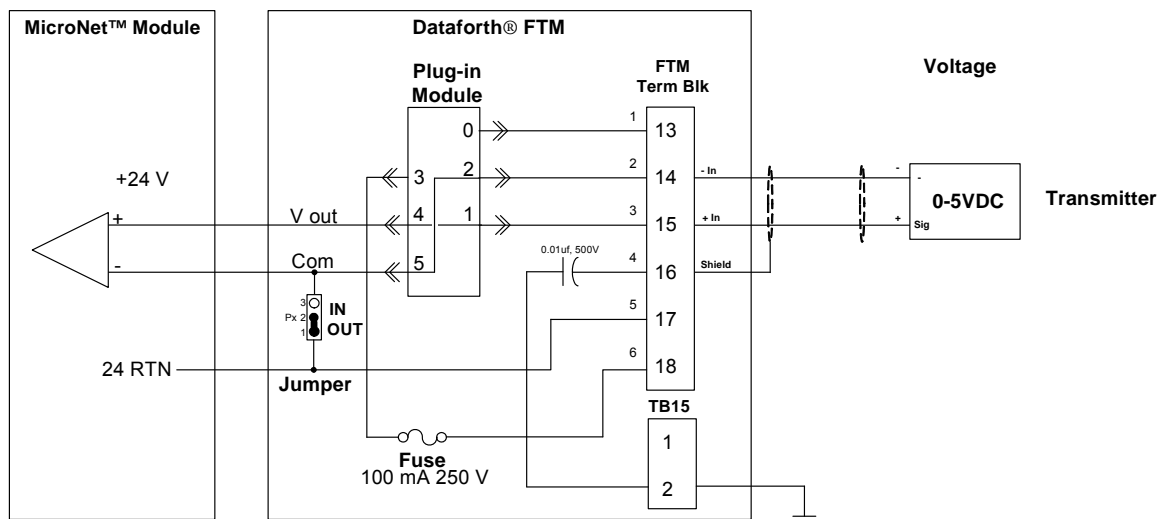

Figure 5-24. 0–5 Vdc Signal Wiring to Simplex Dataforth FTM

5.4.3.6. Analog Output Connection

The Analog Output circuit does not use a plug-in module. No jumper connections are required. See Figure 5-25 for an example of wiring a 4–20 mA output device.

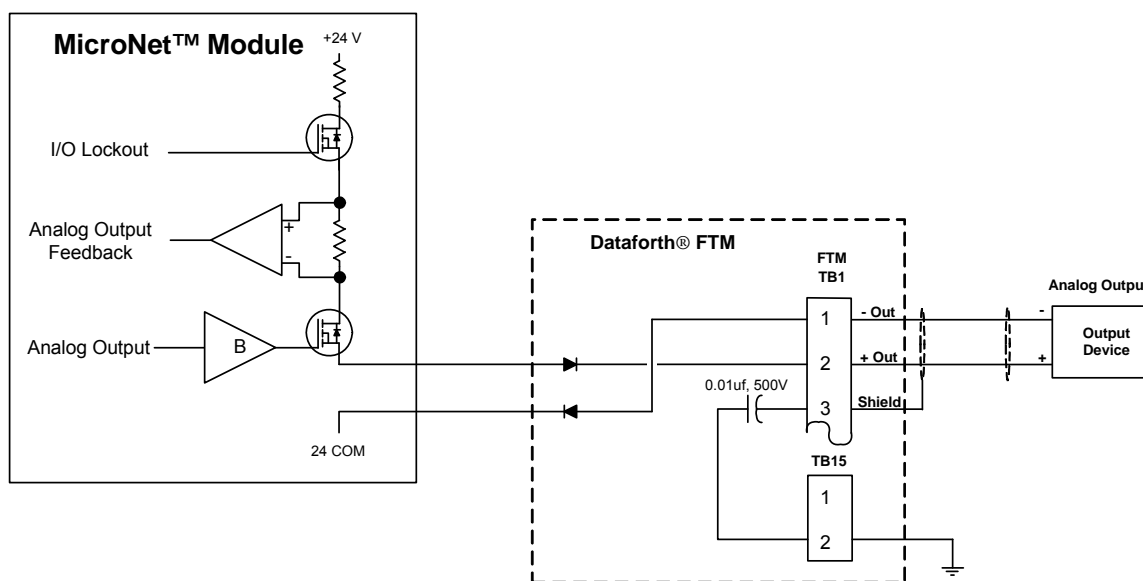

Figure 5-25. Analog Output Signal Wiring to Simplex Dataforth FTM

5.4.4—FTM Reference

See Chapter 12 for complete field wiring of the Simplex Dataforth FTM. See Appendix A for part number Cross Reference for modules, FTMs, and cables.

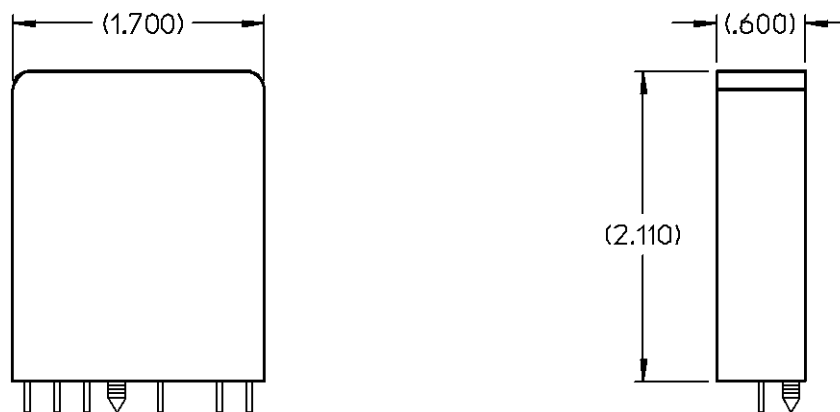

Figure 5-26. Dataforth Plug-in Modules

5.4.5—Troubleshooting

Each Dataforth 24/8 Analog Module has a red Fault LED that is turned on when the system is reset. During initialization of a module, which occurs after every CPU reset, the CPU turns the Fault LED on. The CPU then tests each module using diagnostic routines built into the software. If the diagnostic test is not passed, the LED remains on or blinks. If the test is successful, the LED goes off. If the Fault LED on a module is illuminated after the diagnostics and initialization have been run, the module may be faulty or may be located in the wrong slot.

Table 5-5. LED Indications of Failure

Number of LED Flashes	Failure
1	Hardware watchdog, CPU clock failure, reset fail
2	Micro-controller internal RAM test failure
3	External RAM test failure
4	Unexpected exception error
5	Dual Port RAM test failure
6	EEPROM failure
7	Communications watchdog time out
8	EEPROM error is corrected (reset the module to continue)
9	Missing an A/D Converter interrupt

5.4.5.1. Fault Detection (I/O)

In addition to detecting the High Density Analog I/O module hardware faults, the application software may detect I/O faults.

Analog Input Faults: The application software may be set with a high and low latch setpoint to detect input faults.

Analog Output Driver Faults: The module monitors the source currents and annunciates faults. The application software determines the course of action in the event of a fault.

Microcontroller Faults: The system monitors a software watchdog, a hardware watchdog, and a software watchdog on the VME bus communications. All outputs are shut down in the event of a microcontroller fault.

Troubleshooting Guide

If during normal control operation, all of a chassis' Dataforth 24/8 Analog Module has Fault LEDs on, check the chassis' CPU module for a failure. If during normal control operation, only the Dataforth Module's Fault LED is on or flashing, insure that it is installed in the correct slot. If it is, then replace that module. See instructions for replacement in Chapter 15. When a module fault is detected, its outputs should be disabled or de-energized.

Thermocouple Inputs

If a Thermocouple input is not functioning properly, verify the following:

1. Verify that the correct Dataforth plug-in module is installed. Swap plug-in modules on FTM. Replace module if problem follows module.
2. Check that the cable is shielded and the shield is properly grounded per section Shields and Grounding section in Chapter 14.
3. Verify that there are no or minimal AC components to the Analog Input signal. AC components can be caused by improper shielding.
4. Check the wiring. If the inputs are reading full scale, look for a loose connection on the terminal blocks, disconnected or misconnected cables, a missing jumper on the terminal block, or a blown fuse on the 24 Vdc on the FTM.
5. Check the software configuration to ensure that the input is configured properly.
6. Verify that FTM module is within operating limits of +5 to 45 degrees C.
7. If all of the thermocouple channels on the Dataforth Module are not working, check the fuse on the Dataforth Module. See instructions for module replacement in Chapter 15. This fuse is visible and can be changed through the bottom of the module. If the fuse is blown, fix the wiring problem, then replace the fuse with another fuse of the same type and rating.
8. If the readings are incorrect on several channels of the Dataforth Module, after replacing both cables, replace the module. If replacing the module does not fix the problem, replace the FTM. See instructions for replacing the FTM in Chapter 15.

RTD Inputs

If an RTD input is not functioning properly, verify the following:

1. Verify that the correct Dataforth plug-in module is installed. Swap plug-in modules on FTM. Replace module if problem follows module.
2. Check that the cable is shielded and the shield is properly grounded per section Shields and Grounding section in Chapter 14.
3. Verify that there are no or minimal AC components to the Analog Input signal. AC components can be caused by improper shielding.
4. Check the wiring. If the inputs are minimum scale or full scale, look for a loose connection on the terminal blocks, disconnected or misconnected cables, a missing jumper on the terminal block, or a blown fuse on the 24 Vdc on the FTM.
5. Check the software configuration to ensure that the input is configured properly.
6. If all of the RTD channels on the Dataforth Module are not working, check the fuse on the Dataforth Module. See instructions for module replacement in Chapter 15. This fuse is visible and can be changed through the bottom of the module. If the fuse is blown, fix the wiring problem, then replace the fuse with another fuse of the same type and rating.
7. If the readings are incorrect on several channels of the Dataforth Module, after replacing both cables, replace the module. If replacing the module does not fix the problem, replace the FTM. See instructions for replacing the FTM in Chapter 15.

4–20 mA Analog Inputs

If a 4–20 mA analog input is not functioning properly, verify the following:

1. Verify that the correct Dataforth plug-in module is installed.
2. Check that the cable is shielded and the shield is properly grounded.
3. Measure the input voltage on the FTM terminal block. It should be in the range of 0.8–4.0 V.
4. Verify that there are no or minimal AC components to the Analog Input signal. AC components can be caused by improper shielding.
5. Check the wiring. If the inputs are reading 0 or the engineering units that correspond to 0 mA, look for a loose connection on the terminal blocks, disconnected or misconnected cables, a missing jumper on the terminal block if the input is a current input, or a blown fuse on the 24 Vdc on the FTM.
6. Check the software configuration to ensure that the input is configured properly.
7. If all of the 4–20 mA channels on the Dataforth Module are not working, check the fuse on the Dataforth Module. See instructions for module replacement in Chapter 15. This fuse is visible and can be changed through the bottom of the module. If the fuse is blown, fix the wiring problem, then replace the fuse with another fuse of the same type and rating.
8. If the readings are incorrect on several channels of the Dataforth Module, after replacing both cables, replace the module. If replacing the module does not fix the problem, replace the FTM. The 4–20 mA configured FTM contains only traces and a few discrete components, so failure is extremely unlikely. See instructions for replacing the FTM in Chapter 15.

0–5 Vdc Analog Inputs

If a 0–5 Vdc analog input is not functioning properly, verify the following:

1. Verify that the correct Dataforth plug-in module is installed.
2. Check that the cable is shielded and the shield is properly grounded.
3. Verify that there are no or minimal AC components to the Analog Input signal. AC components can be caused by improper shielding.
4. Check the wiring. If the inputs are minimum scale or full scale, measure the input voltage on the FTM terminal block. It should be in the range of 0.8–4.8 V. Look for a loose connection on the terminal blocks, disconnected or misconnected cables on the terminal block.
5. Check the software configuration to ensure that the input is configured properly.
6. If all of the voltage channels on the Dataforth Module are not working, check the fuse on the Dataforth Module. See instructions for module replacement in Chapter 15. This fuse is visible and can be changed through the bottom of the module. If the fuse is blown, fix the wiring problem, then replace the fuse with another fuse of the same type and rating.

7. If the readings are incorrect on several channels of the Dataforth Module, after replacing both cables, replace the module. If replacing the module does not fix the problem, replace the FTM.

Analog Outputs

If an analog output is not functioning properly, verify the following:

1. Check that the cable is shielded and the shield is properly grounded.
2. Check the load resistance to ensure that it is not greater than 600 ohms.
3. Check to ensure that the load wiring is isolated.
4. Check the wiring for a loose connection on the FTM terminal blocks and disconnected or misconnected cables.
5. Disconnect the field wiring and connect a resistor across the output. If the output is correct across the resistor, there is a problem with the field wiring.
6. If all of the channels on the Dataforth Module are not working, check the fuse on the Dataforth Module. See instructions for module replacement in Chapter 15. This fuse is visible and can be changed through the bottom of the module. If the fuse is blown, fix the wiring problem, then replace the fuse with another fuse of the same type and rating.
7. Check the software configuration to ensure that the output is configured properly.
8. After verifying all of the above, exchange the J1 and J2 cables. If the problem moves to a different channel, replace the cable. If not, replace the module.
9. If the readings are incorrect on several channels of the module, corresponding to both cables, replace the module.
10. 1 If replacing the module does not fix the problem, replace the FTM. The FTM contains only traces and a few discrete components, so failure is extremely unlikely. See instructions for replacing the FTM in Chapter 15.

5.5. 34 Ch. High Density Versatile Input Module (HDVIM)

5.5.1—Module Description

This board includes no potentiometers and requires no calibration. A Configurable 34 Ch. HDVIM module may be replaced with another board of the same part number without any adjustment. Each Configurable 34 Ch. HDVIM Module contains circuitry for 34 Analog inputs and 2 cold junction inputs. 24 of the Analog inputs may be 4–20 mA inputs or thermocouple inputs, and the remaining ten Analog inputs may be 4–20 mA inputs or RTD inputs. The Configurable 34 Ch. HDVIM Module connects to the CPU board through the VME bus.

The first 12 Thermocouple/4–20 mA inputs are isolated as a group, from the other inputs, and from control common. The second 12 Thermocouple/4–20 mA inputs are isolated as a group, from the other inputs, and from control common. The first 4 RTD/4–20 mA inputs are isolated as a group, from the other inputs, and from control common. The second 6 RTD/4–20 mA inputs are isolated as a group, from the other inputs, and from control common.



Figure 5-27. 34 Channel HDVIM Module

5.5.2—Module Specifications

5.5.2.1. Thermocouple/4–20 mA Analog Inputs

Number of channels:	24
Current range:	0–24 mA (if configured for 4–20 mA)
Voltage range:	±72.8 mV (if configured for thermocouple)
Input impedance:	103 ohms (±1%) for 4–20 mA inputs

5.5.2.2. Thermocouple Type and Range

(Type E, J, K, N, R, S, and T thermocouples must conform to the common commercial specifications published in the Annual Book of ASTM Standards with voltage predictions in line with N.I.S.T. Monograph 175 or ITS-90.)

Type E:	–9.83 mV (–267.68 °C/–449.82 °F) to 72.8 mV (952.60 °C/1746.68 °F)
Type J:	–8.09 mV (–209.72 °C/–345.50 °F) to 69.55 mV (1199.94 °C/2191.89 °F)
Type K:	–6.45 mV (–263.95 °C/–443.11 °F) to 54.88 mV (1371.81 °C/2501.26 °F)
Type N:	–4.34 mV (–263.14 °C/–441.65 °F) to 47.51 mV (1299.92 °C/2371.86 °F)
Type R:	–0.22 mV (–48.27 °C/–54.89 °F) to 21.10 mV (1767.88 °C/3214.18 °F)
Type S:	–0.23 mV (–48.60 °C/–55.48 °F) to 18.69 mV (1767.76 °C/3213.97 °F)
Type T:	–6.25 mV (–265.71 °C/–446.28 °F) to 20.87 mV (399.97 °C/751.95 °F)

Common Mode Rejection	–80 dB minimum for Analog inputs –96 dB typical for Analog inputs –110 dB minimum for thermocouple inputs –120 dB typical for thermocouple inputs
Operational Input common Mode voltage range:	±11 V minimum
Maximum Non-operational Common mode voltage range:	±40 V minimum
Anti-aliasing filter:	2 poles at 10 ms (channel 11 has 2 poles at 5 ms)
Resolution:	15 bits
4–20 mA Input Accuracy:	1.1% FS (4–20 mA)

IMPORTANT

The overall accuracy of the 4–20 mA input measurement is dependent on the ambient temperature of the board. The accuracy is based on a board temperature between 0 and 55 °C. The accuracy is in percent of full scale range.

5.5.2.3. Thermocouple Accuracy

The overall accuracy of the thermocouple measurement is dependent on the ambient temperature of the board. The following accuracies are based on a board temperature between 0 and 55°C. All accuracies are in percent of full scale range for the type of thermocouple and the range specified.

Type E(<25°C):	1.15%
Type E(>25°C):	1.08%
Type J(<25°C):	1.09%
Type J(>25°C):	1.07%
Type K(<25°C):	1.14%
Type K(>25°C):	1.08%
Type N(<25°C):	1.21%
Type N(>25°C):	1.09%
Type R(<300°C):	1.16%
Type R(>300°C):	1.09%
Type S(<300°C):	1.16%
Type S(>300°C):	1.09%
Type T(<25°C):	2.53%
Type T(>25°C):	1.27%

IMPORTANT

Thermocouple accuracy may be reduced by RF interference in the 900 MHz to 1.4 GHz frequency range. RF interference may reduce the accuracy another 0.45% of full scale when present.

CJ Update time:	5 ms
CJ accuracy:	±3 °C
Latency	
Odd numbered channels:	1 ms
Even numbered channels:	3 ms
Failure detection:	Open wire detection provided for thermocouples
Isolation:	All input channels are isolated from the rest of the MicroNet platform to 500 Vdc, however they are not isolated from each other. The inputs are differential, with a high impedance between channels.

5.5.2.4. RTD/4–20 mA Analog Inputs

Number of channels:	10
Input type:	100 or 200 ohm 3-wire
Max. input current:	24 mA, if configured for 4–20 mA
Max. input resistance:	781Ω, if configured for RTD
RTD source current:	1 mA

5.5.2.5. RTD Range

(Must conform to DIN (Deutsche Institut for Normung) standard for 100 or 200 ohm European curve (Alpha = .00385) or American curve 100 or 200 ohm curve (Alpha = .00392))

100Ω RTD (European Curve):	18.49 Ω (−200 °C/−328 °F) to 390.48 Ω (850 °C/1562 °F)
200Ω RTD (European Curve):	37.04 Ω (−200 °C/−328 °F) to 533.10 Ω (457 °C/854.6 °F)
100Ω RTD (American Curve):	59.57 Ω (−100 °C/−148 °F) to 269.35 Ω (457 °C/854.6 °F)
200Ω RTD (American Curve):	119.14 Ω (−100 °C/−148 °F) to 538.70 Ω (457 °C/854.6 °F)

Common mode rejection:	−80 dB minimum for analog inputs −96 dB typical for analog inputs −96 dB minimum for RTD inputs −115 dB typical for RTD inputs
Input common mode range:	±11 V minimum
Safe input common mode voltage:	±40 V minimum
Input impedance:	103 ohms (±1%) for 4–20 mA inputs
Anti-aliasing filter:	2 poles at 10 ms
Resolution:	15 bits

5.5.2.6. RTD Accuracy

The overall accuracy of the RTD measurement is dependent on the ambient temperature of the board. The following accuracies are based on a board temperature between 0 and 55°C. All accuracy are in percent of full scale range for the type of RTD specified.

100Ω RTD (European Curve):	1.28% FS
200Ω RTD (European Curve):	1.28% FS
100Ω RTD (American Curve):	1.28% FS
200Ω RTD (American Curve):	1.28% FS

Update time:	5 ms
I/O Latency:	1 ms

Isolation: All input channels are isolated from the rest of the MicroNet platform to 500 Vdc, however inputs are not isolated from each other.

5.5.3—Installation

The modules slide into card guides in the control's chassis and plug into the motherboard. The modules are held in place by two screws, one at the top and one at the bottom of the front panel. Also at the top and bottom of the module are two handles which, when toggled (pushed outward), move the modules out just far enough for the boards to disengage the motherboard connectors.

In a Simplex system, each 34 Ch. HDVIM module is connected through two high density 62 conductor analog cables to two 34 Ch. HDVIM FTMs. All inputs on the module are accessible on the FTM, and the channels are labeled to correspond to their software locations (e.g., analog input 1 on the FTM will be analog input 1 in the application software). See Figure 8-42 for an example.

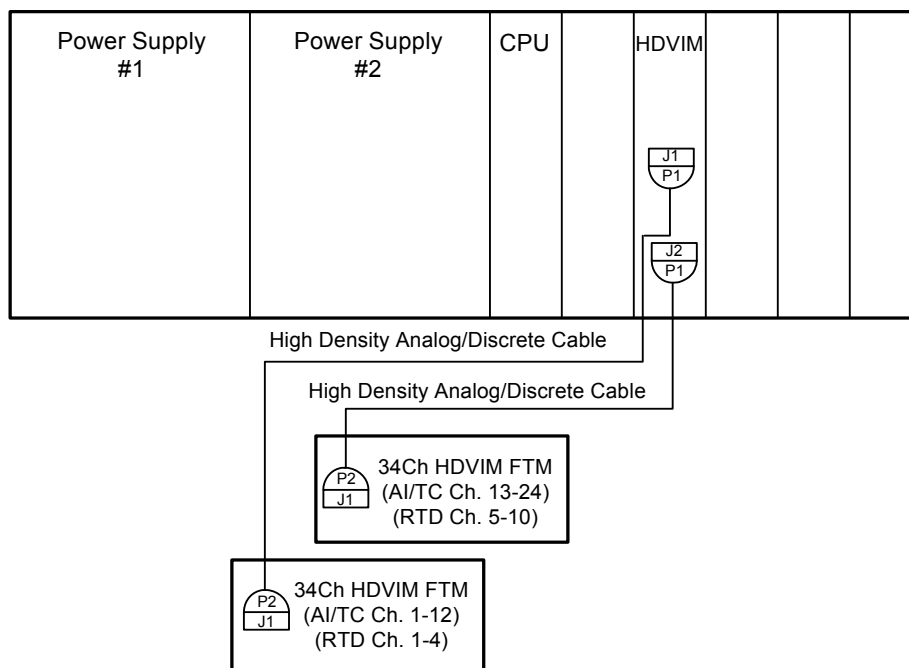

Figure 5-28. Simplex System Configuration Example

Loop power for the Analog inputs must be supplied by an external supply, if needed. This supply should be wired to terminals 40 and 81 on each FTM. The FTM will fuse and distribute the power to 9 sets of terminals on the FTM. The 4–20 mA, thermocouple, or RTD configurable inputs are selected in the GAP block software, for each input. The GAP block configuration sets input gain via software. The maximum wire size that the FTM can accept is one 16 AWG or two 20 AWG wires.

5.5.3.1. 34 Ch. HDVIM Module Operation

All 34 inputs can be configured as 4–20 mA analog inputs. The first 24 channels can be configured as 4–20 mA inputs or thermocouples inputs and the last 10 can be configured as 4–20 mA inputs or RTD inputs. The application software must be configured to match the input type used, i.e. 4–20 mA, 100 ohm RTD, K type thermocouple, etc. This allows the 34 Ch. HDVIM module to use the applicable hardware calibration values, and to configure the appropriate hardware gains. The first thermocouple inputs must be configured in pairs, i.e. channels 1 and 2 must both be thermocouples or must both be 4–20 mA inputs. The RTD channels may be configured individually. Any 'un-used' channel of a pair, Channels 1 - 24, must have its input shorted to prevent measurement errors on the 'in-use' channel of the pair.

AIs ARE 4-20mA
 FUSES 100mA (5X20mm)

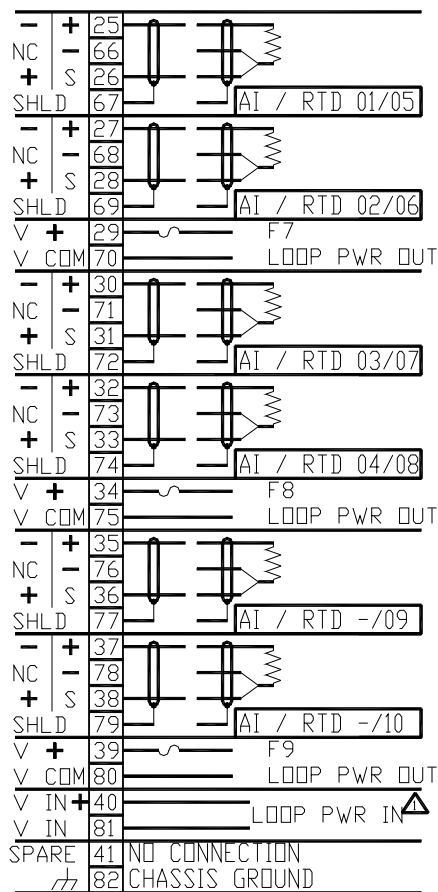
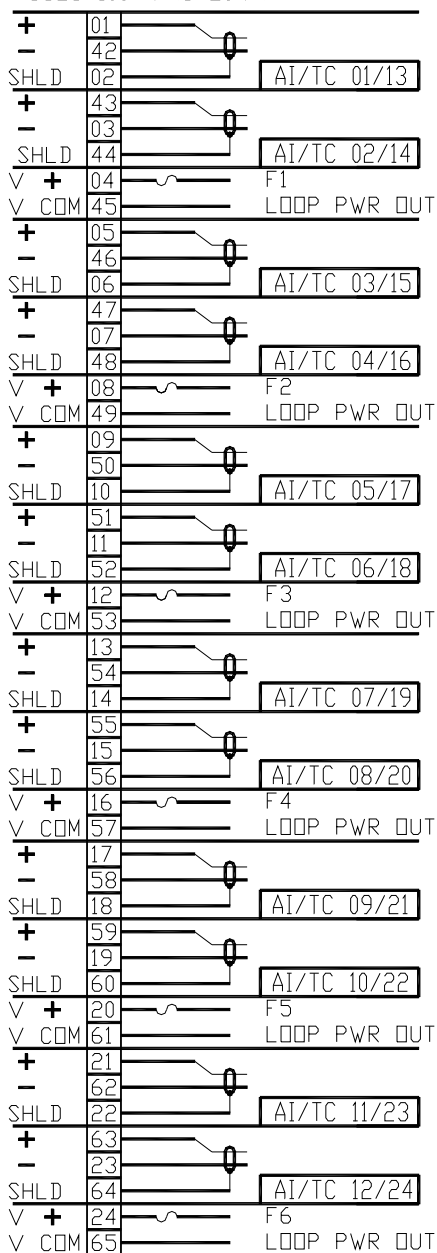

Δ LOOP PWR SUPPLY
 18-32VDC 5A MAX.

855-754
 00-10-12 kdw

Figure 5-29. Wiring Diagram for 34 Ch. HDVIM FTM

IMPORTANT	<p>For MicroNet controls using this module to be CE compliant, the power supply used for the FTM "LOOP POWER" must be isolated, protected, and CE marked to EN61000-6-2 and EN61000-6-4 EMC standards. In addition, chassis ground must be connected at two points on the FTM. Pin 82 with a 16 AWG wire of the shortest length possible, no longer than 4 inches (10 cm). TB2 with a 1/2" wide flat hollow braid, no longer than 6 inches (15 cm).</p>
-----------	---

5.5.3.2. 4–20 mA Inputs

For a 4–20 mA input signal, the 34 Ch. HDVIM module uses a 100 ohm resistor across the input. All 4–20 mA inputs may be used with two-wire ungrounded (loop powered) transducers or isolated (self-powered) transducers. All Analog inputs have 11 Vdc of common mode rejection. If interfacing to a non-isolated device, which may have the potential of reaching over 11 Vdc with respect to the control's common, the use of a loop isolator is recommended to break any return current paths, which could produce erroneous readings. 0–5 V inputs are not supported by this module. No loop power is provided by the MicroNet module. An external supply must be connected to the FTM for powering loop powered inputs.

5.5.3.3. RTD Inputs

RTD inputs must be configured to use either the European or American curve in software. Only 100 and 200 ohm platinum RTDs are supported. 200 ohm RTDs are limited to the maximum temperature on the American curve, even when the European curve is used. The RTD source current is 2 mA, and the RTD sense input should be tied to the negative side of the RTD, at the RTD.

5.5.3.4. Thermocouple Inputs

See Module Specifications for supported thermocouple types. A cold junction sensor is provided on the 34 Ch. HDVIM FTM. If the actual cold junction in the field wiring occurs elsewhere, the temperature of that junction must be brought into the control as a thermocouple, RTD, or 4–20 mA input, and the application software must be configured to use the appropriate cold junction temperature. The thermocouple and cold junction input units (°C or °F) should be consistent in the application software.

The first 12 Analog inputs on each FTM are isolated as a group from control common, earth ground, and the rest of the Analog inputs. The next 4 or 6 Analog inputs on the FTM are also isolated as a group from control common, earth ground, and the rest of the Analog inputs. This results in 4 isolated groups of inputs on each module.

IMPORTANT

If 4–20 mA inputs are configured for the first twelve channels on a FTM, and thermocouple inputs are also used on that FTM, then the 4–20 mA inputs should use an isolated power supply. Similarly, if 4–20 mA inputs are configured for the last 4-6 channels on a FTM, and RTD inputs are also used on that FTM, the 4–20 mA inputs should use an isolated power supply. This prevents 4–20 mA inputs from introducing noise on temperature inputs, when they share the same isolated input ground on the module.

IMPORTANT

The FTM cold junction, has some limited immunity to RF fields. It requires the Loop power to be as noted above. It also requires that the FTM be installed into a metal cabinet as dictated by the application. Standard cabinet for CE Mark & an EMC cabinet for marine installations as dictated in the system installation chapter.

5.5.4—FTM Reference

See Chapter 12 for complete 34 Ch. HDVIM FTM field wiring information. See Appendix A for proper Module, FTM, and cable part numbers.

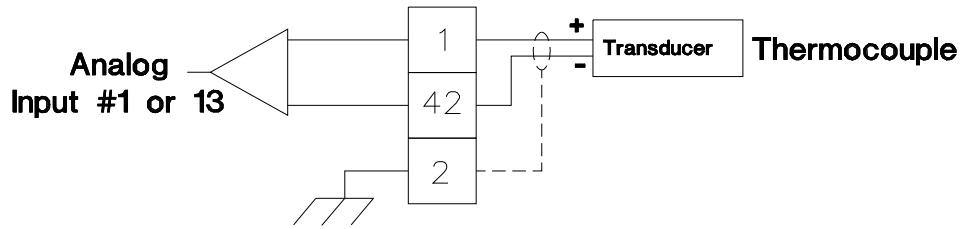

Figure 5-30. Analog Interface Wiring to 34 Ch. HDVIM Module Inputs

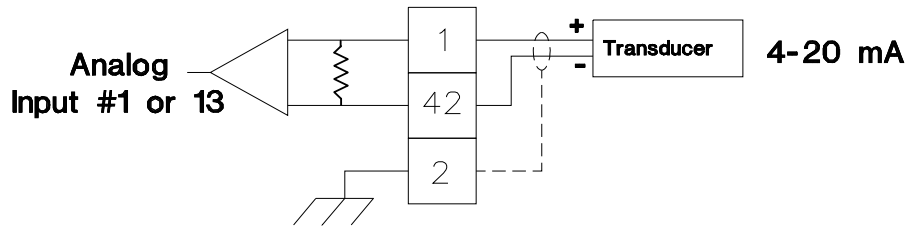

Figure 5-31. Analog Interface Wiring to the 34 Ch. HDVIM Module Inputs

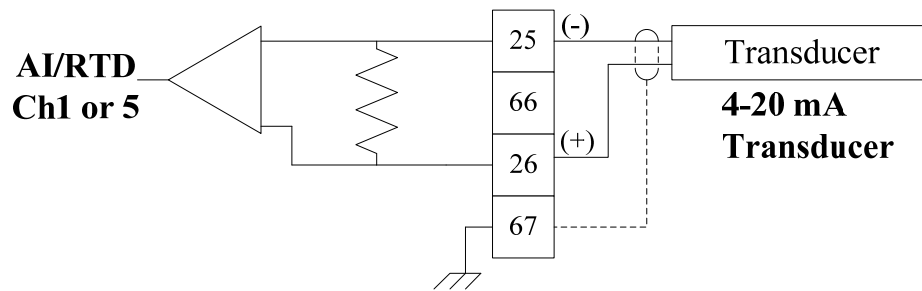

Figure 5-32. 4-20 mA Interface Wiring to 34 Ch. HDVIM Module RTD Inputs

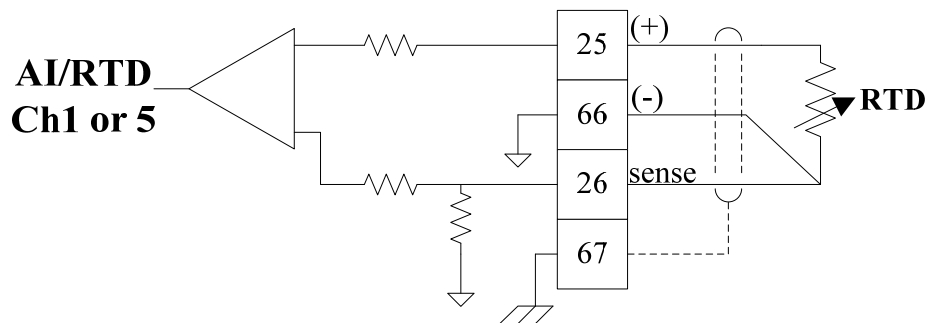

Figure 5-33. RTD Interface Wiring to the 34 Ch. HDVIM Module RTD Inputs

5.5.5—Troubleshooting

Each 34 Ch. HDVIM module has a red fault LED that is turned on when the system is reset. During initialization of a board, which occurs after every CPU reset, the CPU turns the Fault LED on. The CPU then tests the board using diagnostic routines built into the software. If the diagnostic test is not passed, the LED remains on or blinks. If the test is successful, the LED goes off. If the fault LED on a board is illuminated after the diagnostics and initialization have been completed, the 34 Ch. HDVIM module may be faulty.

Table 5-6. LED Indications of Failure

Number of LED Flashes	Failure
1	Micro-Processor failure
2	Bus, Address, any unexpected exception error
3	Internal RAM failure
4	Internal Watchdog failure
5	EEPROM failure
7	Kernel software Watchdog count error
13	Dual port RAM error

5.5.5.1. Fault Detection (I/O)

In addition to detecting board hardware faults, the application program may detect I/O faults.

Analog Input Faults. The application software may set a high and low latch setpoint to detect input faults. For thermocouple inputs, open wire detection is provided.

Micro-controller Faults. The system monitors a software watchdog, a hardware watchdog, and a software watchdog on the VME bus communications. All outputs are shutdown in the event of a microcontroller fault.

Troubleshooting Guide

If an Analog input is not functioning properly, verify the following:

1. Check that the cable is shielded and the shield is properly grounded per the Shields and Grounding section in Chapter 14.
2. Measure the input voltage on the terminal block. It should be in the range of 0–5 V for 4–20 mA inputs. RTD inputs have a 2 mA current source. Thermocouple inputs should have the appropriate millivolt signal.
3. Verify that there are no or minimal AC components to the Analog Input signal. AC components can be caused by improper shielding. Thermocouple inputs are extremely sensitive to signal fluctuations.
4. Check the wiring. For a 4–20 mA input if the input is reading 0 or the engineering units that correspond to 0 mA, look for a loose connection at the terminal blocks and disconnected or misconnected cables.
5. For RTD inputs, check for proper connection of the sense line.
6. For thermocouple inputs, check for proper cold junction location.
7. If the input is reading high, check that the power is not connected across the input directly.
8. Check the software configuration to ensure that the input is configured properly. Ensure that the proper RTD or thermocouple type is selected, if applicable.
9. After verifying all of the above, exchange the J1 and J2 cables. If the problem moves to a different channel, replace the cable. If not, replace the 34 Ch. HDVIM module.
10. If the readings are incorrect on several channels of the 34 Ch. HDVIM module, corresponding to both cables, replace the 34 Ch. HDVIM module.
11. If replacing the module does not fix the problem, replace the FTM. See the instructions in Chapter 15 for replacing the FTM. The FTM contains only traces and a few discrete components, so failure is extremely unlikely.

5.6. Current Input Modules

There are three different 8 Ch. Current Input modules available from Woodward. These consist of the 8 Ch. Current Input (4–20 mA) module, Non-Standard 8 Ch. Current Input (4–20 mA) module, and the 8 Ch. Current/Voltage Input Module. The 8 Ch. Current/Voltage Input module was created for a special program and is not a standard Woodward product.

5.7. 8 Ch. Current Input (4–20 mA) Module

5.7.1—Module Description

Each 8 Ch. Current Input (4–20 mA) Module contains circuitry for eight fully isolated double-ended current inputs. The module is connected through one Low Density Analog cable to one Analog Input FTM for field wiring connections. All analog inputs may be used with two-wire ungrounded (loop powered) transducers or isolated (self-powered) transducers. The Input signal range is between 0 and 25 mA. The module has a built-in precision voltage source. The readings from the precision-voltage reference are used for on-line temperature compensation and automatic calibration for the module.

These modules have no potentiometers and require no calibration. A module may be replaced with another module of the same part number without any adjustment.

5.7.2—Specification

Number of Channels:	8
Input Range:	0–25 mA
Accuracy:	0.5% of full scale
Temperature Coefficient:	12 ppm/degrees C
Anti-aliasing filter	2 poles at 12 ms (Channels 1-8)
Module interface:	VMEbus
Resolution:	16 bit converter
Isolation:	1500 Vac continuous (channel input to control common)
CMRR:	-90 db
Input Impedance:	249 ohms
Status Indication:	RED LED - channel fault or board fault



Figure 5-34. 8 Channel Current Input (4–20 mA) Module

5.7.3—Installation

The modules slide into card guides in the control's chassis and plug into the motherboard. The modules are held in place by two screws, one at the top and one at the bottom of the front panel. Also at the top and bottom of the module are two handles which, when toggled (pushed outward), move the modules out just far enough for the boards to disengage the motherboard connectors.

In a simplex system, each 8 Ch. Current Input (4–20 mA) module is connected through one Low Density Analog cable to one Analog Input FTM. All of the I/O are accessible on the FTM. See Figure 8-49 for configuration.

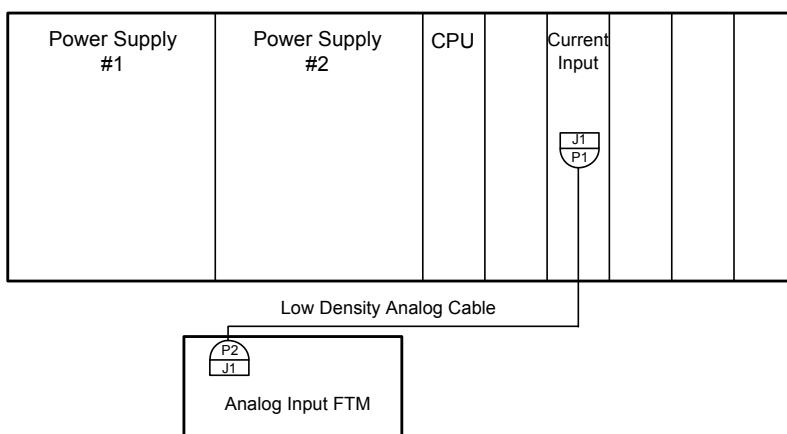

Figure 5-35. 8 Ch. Current Input (4–20 mA) Module Configuration

Field Wiring

See Chapter 12 for complete wiring connections for the Analog Input FTM. See Figure 8-50 for transducer wiring.

All analog inputs may be used with two-wire ungrounded (loop powered) transducers or isolated (self-powered) transducers. Loop powered or self-powered 4–20 mA transducers may be connected to the current input modules via the Analog Input FTM shown in Figure 8-50.

5.7.4—FTM Reference

See Chapter 12 for complete Analog Input FTM field wiring. See Appendix A for proper Module, FTM, and cable part numbers.

5.7.5—Troubleshooting

The input MUX (multiplexer) permits the module to read either the value of the precision-voltage reference for this channel, or the sensed input for this channel. The MUX receives the current input and, under the control of the microcontroller, passes the value through the Gain amplifier to the Isolation Amplifier. The output of the Isolation Amplifier goes to one input of the channel-selecting MUX.

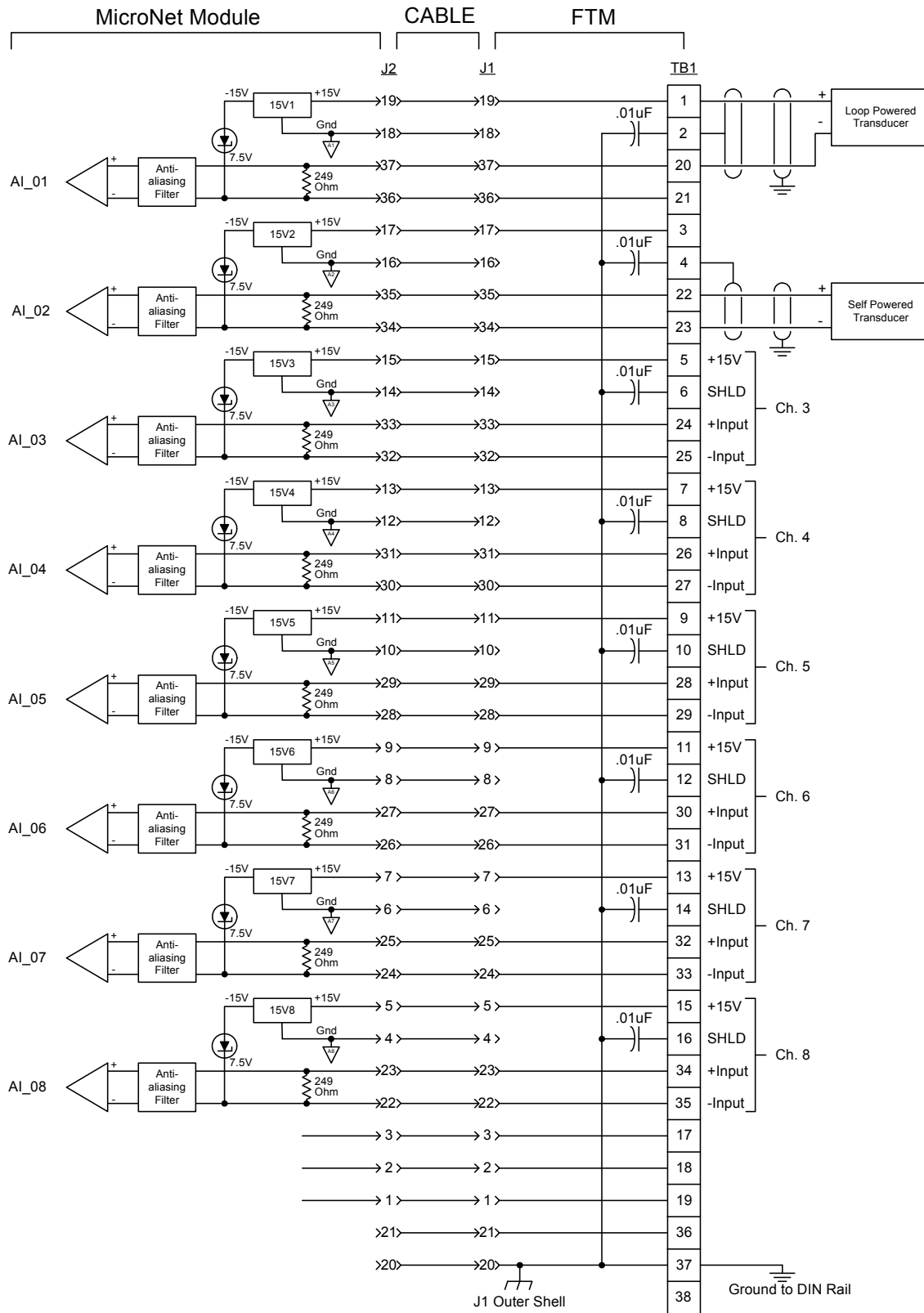

Figure 5-36. Analog Input Wiring for an 8 Ch. Current Input (0-25 mA) Module

This MUX, under control of the microprocessor, selects the channel to be read. The analog output of this MUX is converted to a digital value by the A/D converter, and passed to the microcontroller. The microcontroller makes any necessary corrections to this value and stores the result in the Dual-Port RAM. The CPU can then access the values stored in Dual-Port RAM through the VME interface and bus. See Figure 8-51 for block diagram of module.

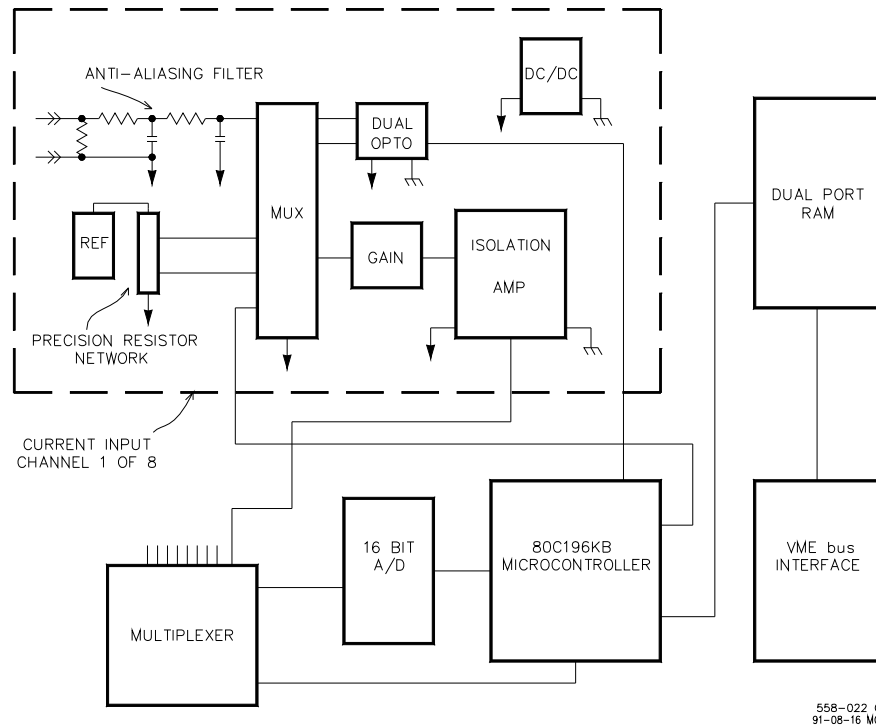

Figure 5-37. 8 Ch. Current Input (0–25 mA) Module Block Diagram

During initialization, which occurs after every reset, the CPU turns the FAULT LEDs on. The CPU then tests each I/O module using diagnostic routines built into software. If the diagnostic test is not passed, the LED remains on. If the test is successful, the LED goes off.

During initialization of the module, the module's micro-controller turns the LED off after power-on self-tests have passed and the CPU has initialized the module.

The CPU also tells this module in which rate group each channel is to run, as well as special information. At run time, the CPU then periodically broadcasts a "key" to all I/O cards, telling them which rate groups are to be updated at that time. Through this initialization/key broadcast system, each I/O module handles its own rate-group scheduling with minimal CPU intervention.

This module also has on-card on-line fault detection and automatic calibration/compensation. Each input channel has its own precision voltage reference. Once per minute, while not reading inputs, the on-board microcontroller reads this reference. The microcontroller then uses this data read from the voltage reference for both fault detection and automatic temperature compensation/calibration.

Limits have been set for the expected readings when the on-board microcontroller reads each voltage reference. If the reading obtained is outside these limits, the system determines that the input channel, A/D converter, or the channel's precision-voltage reference is not functioning properly. If this happens, the micro-controller flags that channel as having a fault condition. The CPU will then take whatever action the application engineer has provided for in the application program.

The readings from the precision-voltage reference are also used for on-line temperature compensation and automatic calibration for the module. The readings of the precision-voltage reference, obtained from the A/D converter, are used by the microcontroller to determine software scaling- and offset-constants for each channel. These scaling-and offset-constants are respectively multiplied by and added to each channel reading to provide corrected channel readings. The module therefore includes no potentiometers and needs no calibration.

Each I/O module has a fuse on it; this fuse is visible and can be changed through a cutout in the plastic cover of the module. If this fuse is blown, replace it with a fuse of the same type and size.

Troubleshooting Guide

If a current input is not functioning properly, verify the following:

1. Check that the cable is shielded and the shield is properly grounded per the Shields and Grounding section in Chapter 14.
2. Measure the input voltage across the + and – inputs on the terminal block. It should be in the range of 0–5 V.
3. Verify that there are no or minimal AC components to the Analog Input signal. AC components can be caused by improper shielding.
4. Check the wiring. If the inputs are reading 0 or the engineering units that correspond to 0 mA, look for a loose connection on the terminal blocks, disconnected or misconnected cables.
5. Check the software configuration to ensure that the input is configured properly.
6. If the other channels on the module are not working either, check the fuse on the 8 Ch. Current Input (0–25 mA) module. This fuse is visible and can be changed through the bottom of the module. If the fuse is blown, fix the wiring problem, then replace the fuse with another fuse of the same type and rating.
7. If the problem remains, swap out the 8 Ch. Current Input (0–25 mA) module with another module of the same part number. If the problem remains, replace the cable.
8. If the problem remains, replace the FTM. The FTM contains only traces and a few discrete components, so failure is extremely unlikely. See instructions for replacing the FTM in Chapter 15.

5.8. Non-Standard 8Ch Current Input (4-20 mA) Module

5.8.1—Module Description

Each Non-Standard 8 Ch. Current Input (4–20 mA) Module utilizes the same circuitry that the 8 Ch. Current Input (4–20 mA) module uses. Seven of the eight double-ended channels of this module are fully isolated. Through the use of a special FTM and cable, the derivative of the signal from channel 7 is generated on the FTM and then fed to channel 8 on the analog Input module. This derivative signal can be used for monitoring a rate of change in the channel 7 input transducer. The first seven channels may be connected to current transducers. Channels 1 through 6 are standard 0–25 mA inputs with standard frequency response. Channel 7 has been altered to allow for higher frequency response. The module has a built-in precision voltage source. The readings from the precision-voltage reference are used for on-line temperature compensation and automatic calibration for the module.

These modules have no potentiometers and require no calibration. A module may be replaced with another module of the same part number without any adjustment.



Figure 5-38. Non-standard 8 Channel Current Input (4–20 mA) Module

5.8.2—Specification

Number of Channels:	8
Input Range:	0–25 mA
Accuracy:	0.5% of full scale
Temperature Coefficient:	12 ppm/degrees C
Anti-aliasing filter	2 poles at 12 ms (Channels 1-6)
Anti-aliasing filter	2 poles at 5 ms (Channels 7-8) (Channel 8 is the derivative of channel 7.)
Module interface:	VMEbus
Resolution:	16 bit converter
Isolation:	1500 Vac continuous (channel input to control common)
CMRR:	-90 db
Input Impedance:	249 Ohms
Status Indication:	RED LED - channel fault or board fault

5.8.3—Installation

The modules slide into card guides in the control's chassis and plug into the motherboard. The modules are held in place by two screws, one at the top and one at the bottom of the front panel. Also at the top and bottom of the module are two handles which, when toggled (pushed outward), move the modules out just far enough for the boards to disengage the motherboard connectors.

In a simplex system, each 8 Ch. Current Input module is connected through one analog cable to one FTM. All of the I/O are accessible on the FTM.

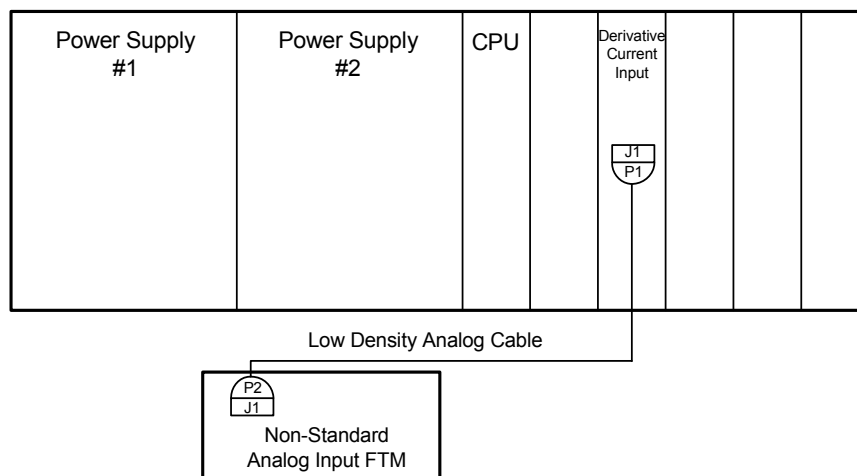

Figure 5-39. Non-Standard 8 Channel Module Configuration

Field Wiring

See Chapter 12 for complete wiring connections for the Non-standard Analog Input FTM. See Figure 8-54 for transducer wiring.

The first six analog inputs may be used with two-wire ungrounded (loop powered) transducers or isolated (self-powered) transducers. The seventh channel can be used with a self-powered transducer only. Channel eight should not be connected to any field wiring. Loop powered or self-powered 4–20 mA transducers may be connected to the current input modules via the Non-Standard Analog Input FTM shown in Figure 8-54.

5.8.4—FTM Reference

The output from channel seven is split and fed to channel seven on the Non-Standard Current Input (4–20 mA) Module and also fed through a derivative circuit on the FTM to channel eight on the Non-Standard Current Input (4–20 mA) Module. See Chapter 12 for complete field wiring information for the Non-Standard Analog Input FTM. See Appendix A for proper Module, FTM, and cable part numbers.

5.8.5—Troubleshooting

The input MUX (multiplexer) permits the module to read either the value of the precision-voltage reference for this channel, or the sensed input for this channel. The MUX receives the current input and, under the control of the microcontroller, passes the value through the Gain amplifier to the Isolation Amplifier. The output of the Isolation Amplifier goes to one input of the channel-selecting MUX.

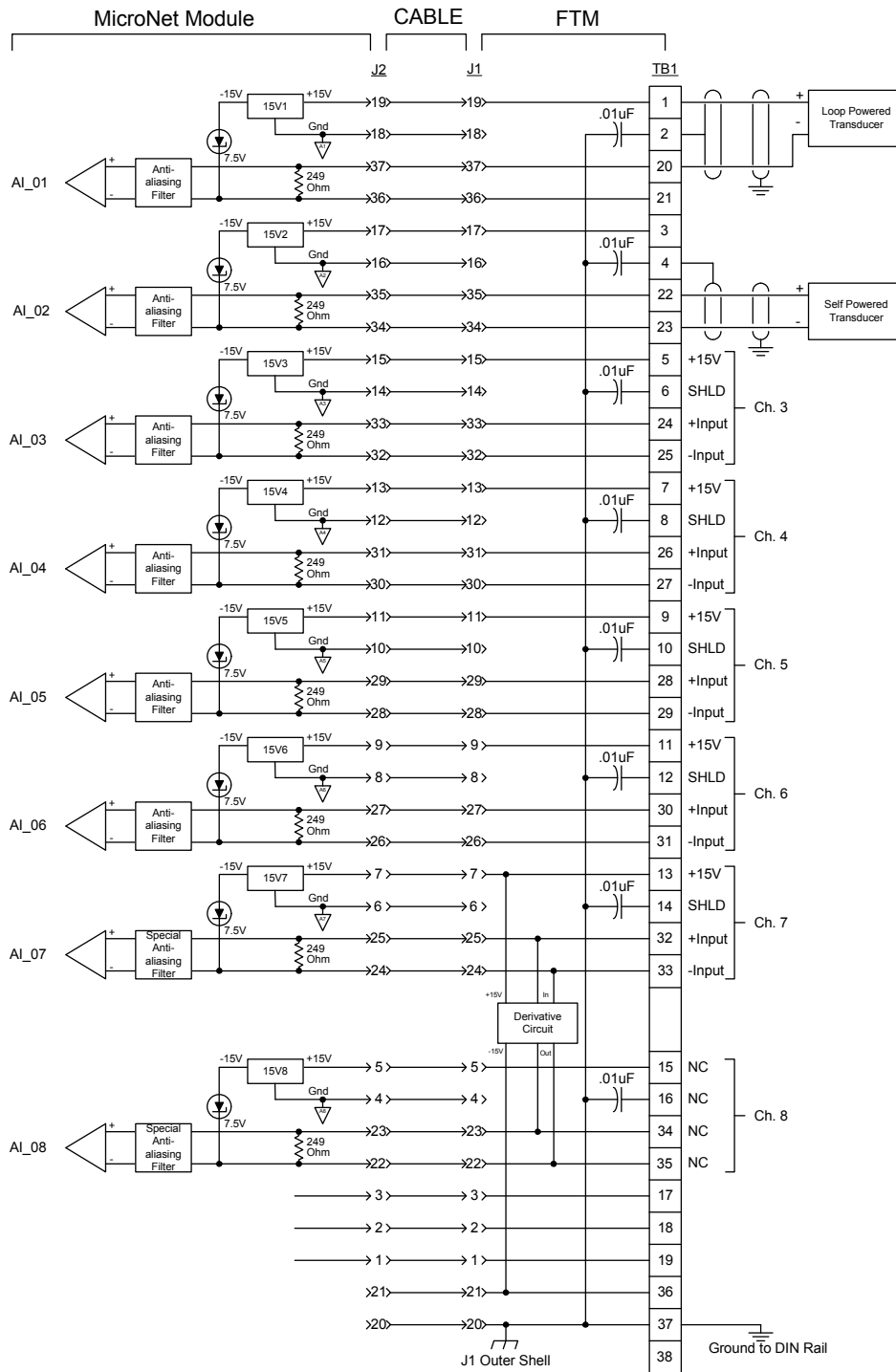

Figure 5-40. Analog Input Wiring for a Non-Standard Module

This MUX, under control of the microprocessor, selects the channel to be read. The analog output of this MUX is converted to a digital value by the A/D converter, and passed to the microcontroller. The microcontroller makes any necessary corrections to this value and stores the result in the Dual-Port RAM. The CPU can then access the values stored in Dual-Port RAM through the VME interface and bus. See Figure 8-51 for block diagram of module.

During initialization, which occurs after every reset, the CPU turns the FAULT LEDs on. The CPU then tests each I/O module using diagnostic routines built into software. If the diagnostic test is not passed, the LED remains on. If the test is successful, the LED goes off.

During initialization of the module, the module's micro-controller turns the LED off after power-on self-tests have passed and the CPU has initialized the module.

The CPU also tells this module in which rate group each channel is to run, as well as special information. At run time, the CPU then periodically broadcasts a "key" to all I/O cards, telling them which rate groups are to be updated at that time. Through this initialization/key broadcast system, each I/O module handles its own rate-group scheduling with minimal CPU intervention.

This module also has on-card on-line fault detection and automatic calibration/compensation. Each input channel has its own precision voltage reference. Once per minute, while not reading inputs, the on-board microcontroller reads this reference. The microcontroller then uses this data read from the voltage reference for both fault detection and automatic temperature compensation/calibration.

Limits have been set for the expected readings when the on-board microcontroller reads each voltage reference. If the reading obtained is outside these limits, the system determines that the input channel, A/D converter, or the channel's precision-voltage reference is not functioning properly. If this happens, the micro-controller flags that channel as having a fault condition. The CPU will then take whatever action the application engineer has provided for in the application program.

The readings from the precision-voltage reference are also used for on-line temperature compensation and automatic calibration for the module. The readings of the precision-voltage reference, obtained from the A/D converter, are used by the microcontroller to determine software scaling- and offset-constants for each channel. These scaling-and offset-constants are respectively multiplied by and added to each channel reading to provide corrected channel readings. The module therefore includes no potentiometers and needs no calibration.

Each I/O module has a fuse on it; this fuse is visible and can be changed through a cutout in the plastic cover of the module. If this fuse is blown, replace it with a fuse of the same type and size.

Troubleshooting Guide

If a current input is not functioning properly, verify the following:

1. Check that the cable is shielded and the shield is properly grounded per the Shields and Grounding section in Chapter 14.
2. Measure the input voltage across the + and – inputs on the terminal block. It should be in the range of 0–5 V.
3. Verify that there are no or minimal AC components to the Analog Input signal. AC components can be caused by improper shielding.
4. Check the wiring. If the inputs are reading 0 or the engineering units that correspond to 0 mA, look for a loose connection on the terminal blocks, disconnected or misconnected cables.
5. Check the software configuration to ensure that the input is configured properly.
6. If the other channels on the module are not working either, check the fuse on the Non-Standard 8 Ch. Current Input (0–25 mA) module. This fuse is visible and can be changed through the bottom of the module. If the fuse is blown, fix the wiring problem, then replace the fuse with another fuse of the same type and rating.
7. If the problem remains, swap out the Non-Standard 8 Ch. Current Input (0–25 mA) module with another module of the same part number. If the problem remains, replace the cable.

If the problem remains, replace the FTM. The FTM contains only traces and a few discrete components, so failure is extremely unlikely. See instructions for replacing the FTM in Chapter 15

5.9. Voltage Input Module

There is one voltage input module available from Woodward.

5.10. 8 Channel Voltage Input (0-10 Vdc) Module

5.10.1—Module Description

Each 8 Ch. Voltage Input (0–10 Vdc) Module has eight channels for 0–10 Vdc transducers. All eight channels are fully isolated double-ended voltage inputs. The module is connected through one Low Density Analog cable to one Analog Input FTM for field wiring connections. The module has a built-in precision voltage source. The readings from the precision-voltage reference are used for on-line temperature compensation and automatic calibration for the module.

These modules have no potentiometers and require no calibration. A module may be replaced with another module of the same part number without any adjustment.



Figure 5-41. 8 Channel Voltage Input (0–10 Vdc) Module

5.10.2—Specification

Number of Channels:	8
Input Range:	0–10 Volts
Accuracy:	0.5% of full scale
Temperature Coefficient:	12 ppm/degrees C

Anti-aliasing filter	2 poles at 12 ms (Channels 1-8)
Module interface:	VMEbus
Resolution:	16 bit converter
Isolation:	1500 Vac continuous (channel input to control common)
CMRR:	-90 db
Input Impedance:	$\geq 2 \text{ M}\Omega$
Status Indication:	RED LED - channel fault or board fault

5.10.3—Installation

The modules slide into card guides in the control's chassis and plug into the motherboard. The modules are held in place by two screws, one at the top and one at the bottom of the front panel. Also at the top and bottom of the module are two handles which, when toggled (pushed outward), move the modules out just far enough for the boards to disengage the motherboard connectors. In a simplex system, each 8 Ch. Voltage Input module is connected through one analog cable to one FTM. All of the I/O are accessible on the FTM.

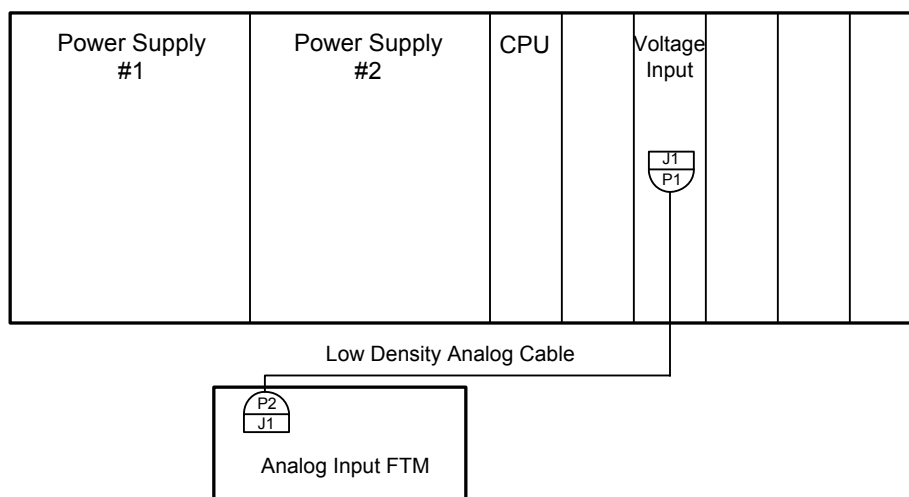

Figure 5-42. 8 Ch. Voltage Input (0–10 Vdc) Module Configuration

Field Wiring

See Chapter 12 for complete wiring connections for the Analog Input FTM. See Figure 8-57 for transducer wiring.

5.10.4—FTM Reference

See Chapter 12 for complete field wiring information for the Voltage Input (0–10 Vdc) FTM. See Appendix A for part number Cross Reference for modules, FTMs, and cables.

5.10.5—Troubleshooting

The input MUX (multiplexer) permits the module to read either the value of the precision-voltage reference for this channel, or the sensed input for this channel. The MUX receives the voltage input and, under the control of the microcontroller, passes the value through the Gain amplifier to the Isolation Amplifier. The output of the Isolation Amplifier goes to one input of the channel-selecting MUX.

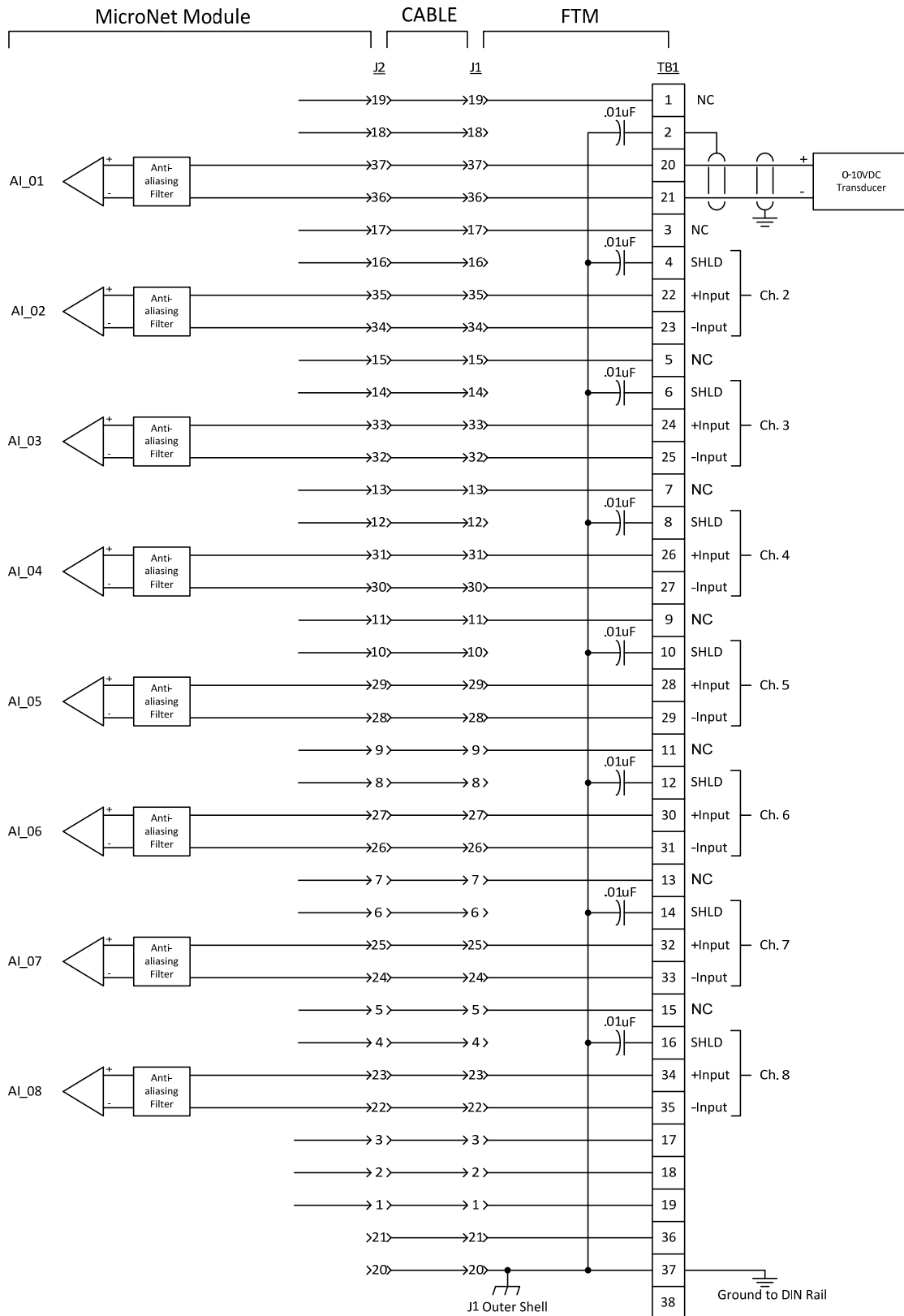

Figure 5-43. Voltage Input Wiring for an 8 Chnl Voltage Input Module

This MUX, under control of the microprocessor, selects the channel to be read. The analog output of this MUX is converted to a digital value by the A/D converter, and passed to the microcontroller. The microcontroller makes any necessary corrections to this value and stores the result in the Dual-Port RAM. The CPU can then access the values stored in Dual-Port RAM through the VME interface and bus. See Figure 8-58 for block diagram of module.

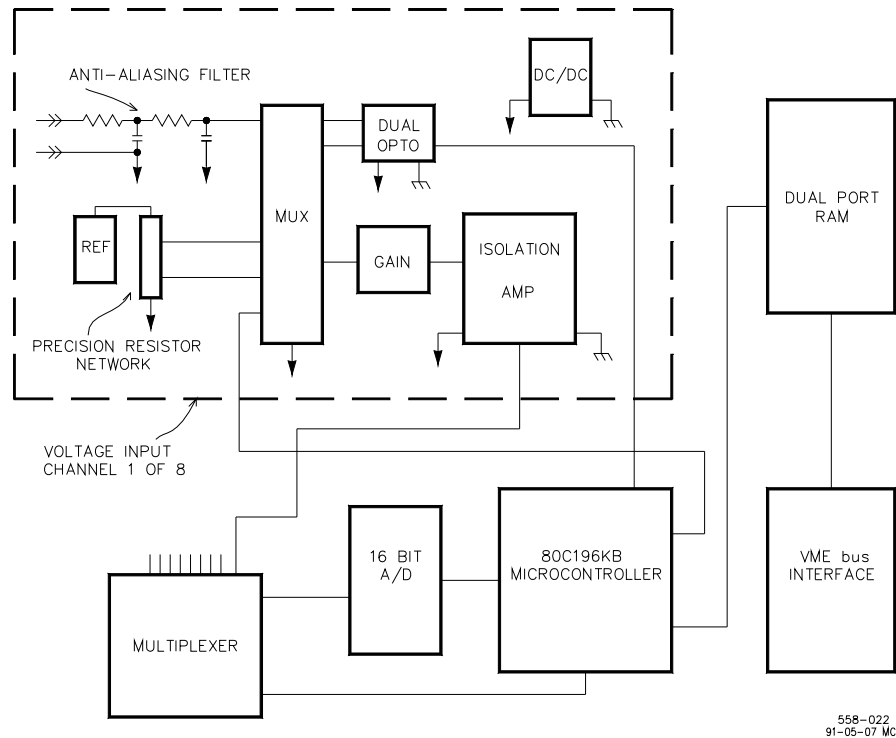

Figure 5-44. 8 Ch. Voltage Input (0–10 Vdc) Module Block Diagram

During initialization, which occurs after every reset, the CPU turns the FAULT LEDs on. The CPU then tests each I/O module using diagnostic routines built into software. If the diagnostic test is not passed, the LED remains on. If the test is successful, the LED goes off.

During initialization of the module, the module's micro-controller turns the LED off after power-on self-tests have passed and the CPU has initialized the module.

The CPU also tells this module in which rate group each channel is to run, as well as special information. At run time, the CPU then periodically broadcasts a "key" to all I/O cards, telling them which rate groups are to be updated at that time. Through this initialization/key broadcast system, each I/O module handles its own rate-group scheduling with minimal CPU intervention.

This module also has on-card on-line fault detection and automatic calibration/compensation. Each input channel has its own precision voltage reference. Once per minute, while not reading inputs, the on-board microcontroller reads this reference. The microcontroller then uses this data read from the voltage reference for both fault detection and automatic temperature compensation/calibration.

Limits have been set for the expected readings when the on-board microcontroller reads each voltage reference. If the reading obtained is outside these limits, the system determines that the input channel, A/D converter, or the channel's precision-voltage reference is not functioning properly. If this happens, the micro-controller flags that channel as having a fault condition. The CPU will then take whatever action the application engineer has provided for in the application program.

The readings from the precision-voltage reference are also used for on-line temperature compensation and automatic calibration for the module. The readings of the precision-voltage reference, obtained from the A/D converter, are used by the microcontroller to determine software scaling- and offset-constants for each channel. These scaling-and offset-constants are respectively multiplied by and added to each channel reading to provide corrected channel readings. The module therefore includes no potentiometers and needs no calibration.

Each I/O module has a fuse on it; this fuse is visible and can be changed through a cutout in the plastic cover of the module. If this fuse is blown, replace it with a fuse of the same type and size.

Troubleshooting Guide

If a voltage input is not functioning properly, verify the following:

1. Check that the cable is shielded and the shield is properly grounded per the Shields and Grounding section in Chapter 14.
2. Measure the input voltage across the + and – inputs on the terminal block. It should be in the range of 0–5 V.
3. Verify that there are no or minimal AC components to the Analog Input signal. AC components can be caused by improper shielding.
4. Check the wiring. If the inputs are reading 0 or the engineering units that correspond to 0 V, look for a loose connection on the terminal blocks, disconnected or misconnected cables.
5. Check the software configuration to ensure that the input is configured properly.
6. If the other channels on the module are not working either, check the fuse on the 8 Ch. Voltage Input (0–10 Vdc) module. This fuse is visible and can be changed through the bottom of the module. If the fuse is blown, fix the wiring problem, then replace the fuse with another fuse of the same type and rating.
7. If the problem remains, swap out the 8 Ch. Voltage Input (0–10 Vdc) module with another module of the same part number. If the problem remains, replace the cable.
8. If the problem remains, replace the FTM. The FTM contains only traces and a few discrete components, so failure is extremely unlikely. See instructions for replacing the FTM in Chapter 15.

5.11. Current Output Modules

There are two Current Output modules.

5.12. 8Ch Current Output (4-20 mA) Module

5.12.1—Module Description

Each 8 Ch. Current Output (4–20 mA) Module has eight channels for outputting 0–25 mA. The module is connected through one Low Density Analog cable to one Analog Input FTM for field wiring connections.

These modules have no potentiometers and require no calibration. A module may be replaced with another module of the same part number without any adjustment.



Figure 5-45. 8 Channel Current Output (4–20 mA) Module

5.12.2—Specification

Number of Channels:	8
Current range:	0–25 mA
Maximum load resistance:	600 ohms max.
Analog Channel bandwidth:	500 Hz min.
Module interface:	VMEbus
Output update time:	1 ms
Resolution:	12 bit
Accuracy:	0.1% of full scale @25 degrees C
Maximum Drift:	50 ppm/degrees C
Status Indication:	RED LED - channel fault or board fault
Channel faults:	Output current monitored
Microcontroller faults:	System monitors a software watchdog
System faults:	All outputs are set to zero if MFT is lost.
Operating Temp:	0 to 70 °C
Isolation:	None

5.12.3—Installation

The modules slide into card guides in the control's chassis and plug into the motherboard. The modules are held in place by two screws, one at the top and one at the bottom of the front panel. Also at the top and bottom of the module are two handles which, when toggled (pushed outward), move the modules out just far enough for the boards to disengage the motherboard connectors.

In a simplex system, each 8 Ch. Current Output module is connected through one analog cable to one FTM. All of the I/O are accessible on the FTM.

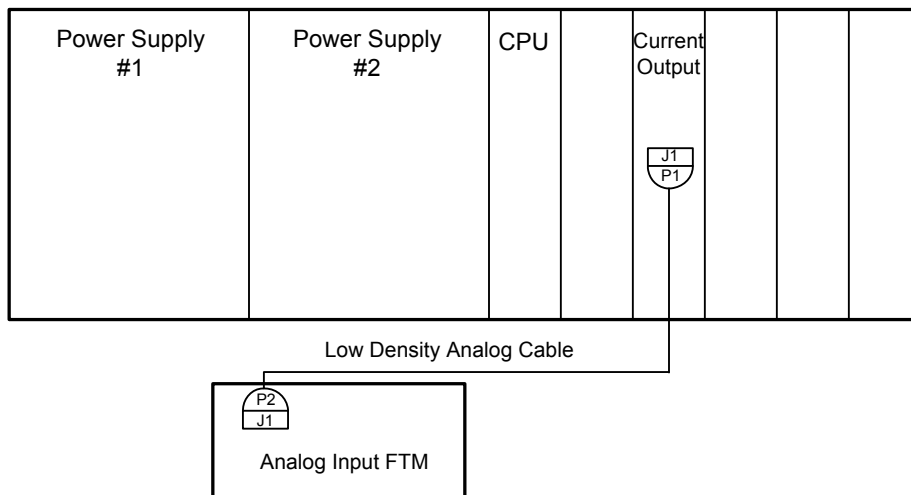

Figure 5-46. 8 Ch. Current Output (4–20 mA) Module Configuration

There are 8 analog output channels of 4–20 mA with a full scale range of 0–25 mA. All Analog Outputs can drive a maximum load of 600 ohms (load + wire resistance). See Figure 8-61 for analog output connection. Each output monitors the output source current for fault detection. All of the analog outputs may be individually disabled. When a channel fault or a module fault is detected, the application program may annunciate the fault, disable the channel and stop using data in system calculations or control. Care should be taken to prevent ground loops and other faults when interfacing to non-isolated devices.

5.12.4—FTM Reference

See Chapter 12 for complete field wiring information for the 8 Ch. Current Output (4–20 mA) FTM. See Appendix A for part number Cross Reference for modules, FTMs, and cables.

5.12.5—Troubleshooting

The system writes output values to the Dual-Port RAM through the VME bus and interface. The microcontroller scales the data using calibration constants stored in EEPROM, and schedules outputs to occur at the proper time.

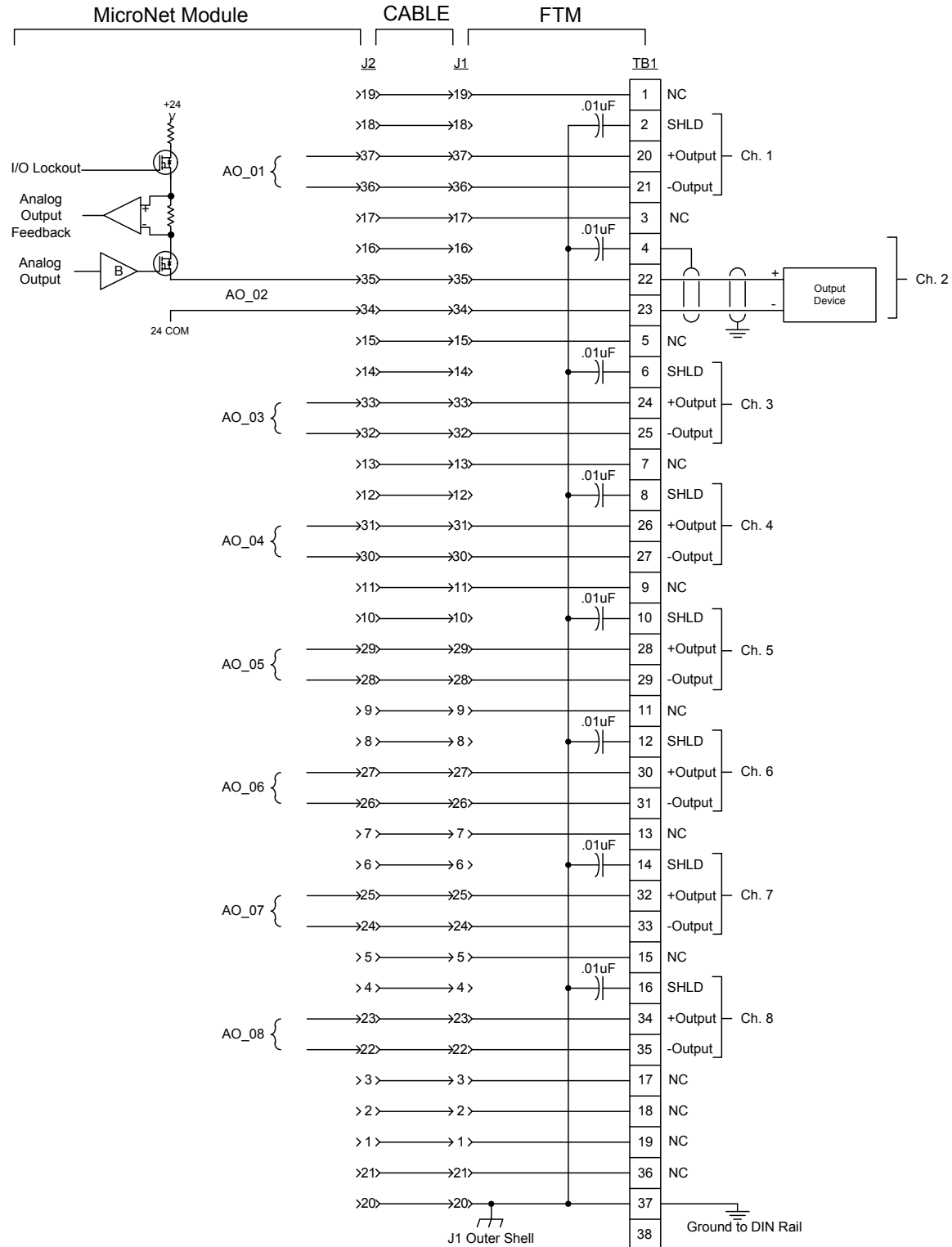

Figure 5-47. Analog Output Wiring for 8 Chnl Output (4–20 mA) Module

The microcontroller monitors the output current of each channel and alerts the system if a fault is detected. The current-output drivers can be disabled by the system. If a fault, which prevents the entire card from operating is detected by either the microcontroller or the system, the FAULT LED will illuminate. See Figure 8-62 for module block diagram.

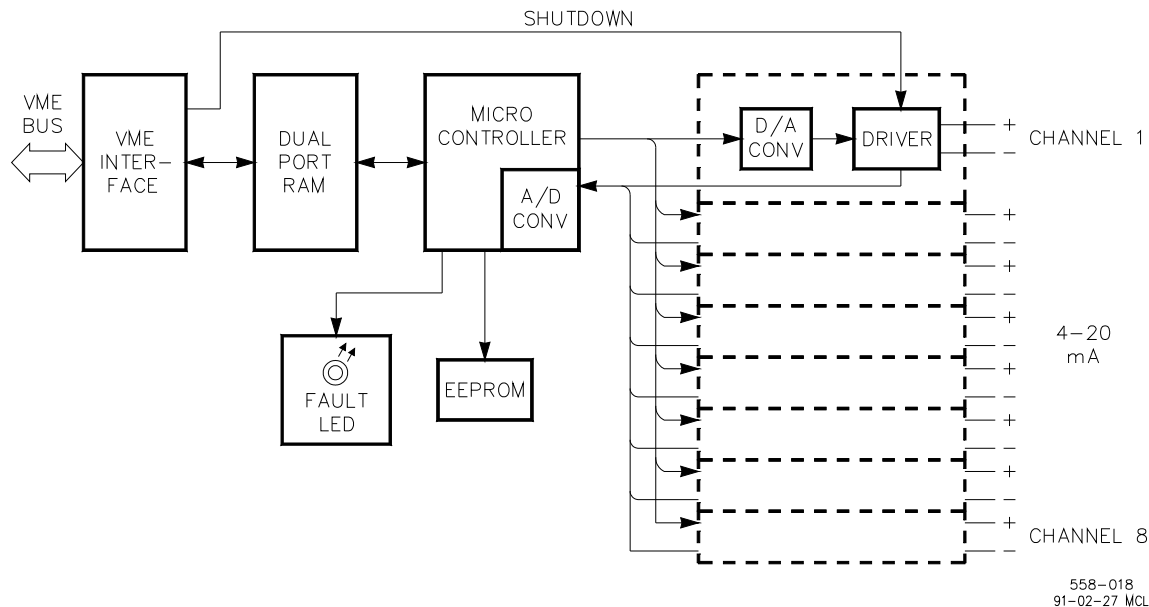

Figure 5-48. Current Output (4–20 mA) Module Block Diagram

If an analog output is not functioning properly, verify the following:

1. Check that the cable is shielded and the shield is properly grounded per the Shields and Grounding section in Chapter 14.
2. Check the load resistance to ensure that it is not greater than 600 ohms.
3. Check to ensure that the load wiring is isolated.
4. Check the wiring for a loose connection on the terminal blocks and disconnected or misconnected cables.
5. Disconnect the field wiring and connect a resistor across the output. If the output is correct across the resistor, there is a problem with the field wiring.
6. If the other output channels on the 8 Ch. Current Output (4–20 mA) Module are also not working, check the fuse on the 8 Ch. Current Output (4–20 mA) Module. See instructions for module replacement in Chapter 15. This fuse is visible and can be changed through the bottom of the module. If the fuse is blown, fix the wiring problem and replace the fuse with a fuse of the same type and rating.
7. Check the software configuration to ensure that the output is configured properly.
8. After verifying all of the above, replace the 8 Ch. Current Output (4–20 mA) Module.
9. If replacing the module does not fix the problem, replace the FTM. See instructions for replacing the FTM in Chapter 15. The FTM does not contain any active components on the MPU inputs, so replacing it should be the last option.

5.13. 8Ch Current Output (0–1 mA) Module

5.13.1—Module Description

Each 8 Ch. Current Output (0–1 mA) Module has eight channels for outputting 0–1 mA. The module is connected through one Low Density Analog cable to one Analog Input FTM for field wiring connections. This module utilizes the same circuits that the 8 Ch. Current Output (0–20 mA) Module uses.

These modules have no potentiometers and require no calibration. A module may be replaced with another module of the same part number without any adjustment.



Figure 5-49. 8 Channel Current Output (0–1 mA) Module

5.13.2—Specification

Number of Channels:	8
Current range:	0 – 1.25 mA
Maximum load resistance:	10 k Ω max.
Analog Channel bandwidth:	500 Hz min.
Module interface:	VMEbus
Output update time:	1 ms
Resolution:	12 bit
Accuracy:	0.1% of full scale @25 °C
Maximum Drift:	50 ppm/degrees C
Status Indication:	RED LED - channel fault or board fault
Channel faults:	Output current monitored
Microcontroller faults:	System monitors a software watchdog
System faults:	All outputs are set to zero if MFT is lost.
Operating Temp:	0 to 70 °C
Isolation:	None

5.13.3—Installation

See 8 Ch. Current Output (4–20 mA) Module.

5.13.4—FTM Reference

See Chapter 12 for complete field wiring information for the 8 Ch. Current Output (0–1 mA) FTM. See Appendix A for part number Cross Reference for modules, FTMs, and cables.

5.13.5—Troubleshooting

See 8 Ch. Current Output (4–20 mA) Module.

5.14. Voltage Output Modules

There are two Current Output modules.

5.15. 8Ch Voltage Output (0-5 Vdc) Module

5.15.1—Module Description

Each 8 Ch. Voltage Output (0–5 Vdc) Module has eight channels for outputting 0–5 Vdc. The module is connected through one Low Density Analog cable to one Analog Input FTM for field wiring connections.

These modules have no potentiometers and require no calibration. A module may be replaced with another module of the same part number without any adjustment.



Figure 5-50. 8 Channel Voltage Output (0–5 Vdc) Module

5.15.2—Specification

Number of Channels:	8
Current range:	0–6.25 V
Minimum load resistance:	500 ohms
Analog Channel bandwidth:	500 Hz min.
Module interface:	VMEbus
Output update time:	1 ms
Resolution:	12 bit
Accuracy:	0.1% of full scale @25 °C
Maximum Drift:	50 ppm/degrees C
Status Indication:	RED LED - channel fault or board fault
Channel faults:	Output current monitored
Microcontroller faults:	System monitors a software watchdog
System faults:	All outputs are set to zero if MFT is lost.
Operating Temp:	0 to 70 °C
Isolation:	None

5.15.3—Installation

The modules slide into card guides in the control's chassis and plug into the motherboard. The modules are held in place by two screws, one at the top and one at the bottom of the front panel. Also at the top and bottom of the module are two handles which, when toggled (pushed outward), move the modules out just far enough for the boards to disengage the motherboard connectors.

In a simplex system, each 8 Ch. Voltage Output module is connected through one analog cable to one FTM. All of the I/O are accessible on the FTM.

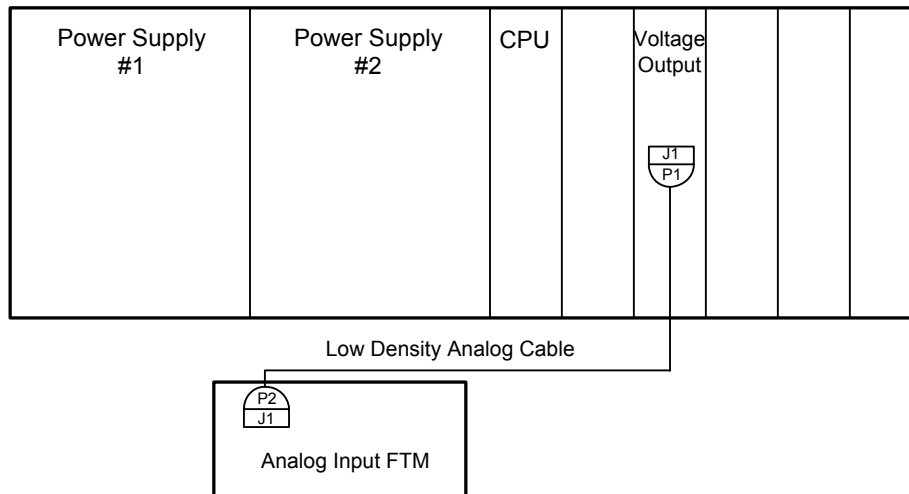

Figure 5-51. 8 Ch. Voltage Output (0–5 Vdc) Module Configuration

There are 8 analog output channels of 0–5 Vdc with a full scale range of 0–6.25 Vdc. All Analog Outputs can drive a minimum load of 500 ohms (load + wire resistance). See Figure 8-66 for analog output connection. Each output monitors the output source voltage for fault detection. All of the analog outputs may be individually disabled. When a channel fault or a module fault is detected, the application program may annunciate the fault, disable the channel and stop using data in system calculations or control. Care should be taken to prevent ground loops and other faults when interfacing to non-isolated devices.

5.15.4—FTM Reference

See Chapter 12 for complete field wiring information for the 8 Ch. Voltage Output (0–5 Vdc) FTM. See Appendix A for part number Cross Reference for modules, FTMs, and cables.

5.15.5—Troubleshooting

Figure 8-67 is a block diagram of the Voltage Output Module with eight 0–5 Vdc outputs.

The system writes output values to the Dual-Port RAM through the VME bus and interface. The microcontroller scales the data using calibration constants stored in EEPROM, and schedules outputs to occur at the proper time.

The microcontroller monitors the output voltage of each channel and alerts the system if a fault is detected. If a fault, which prevents the entire card from operating is detected by either the microcontroller or the system, the FAULT LED will illuminate.

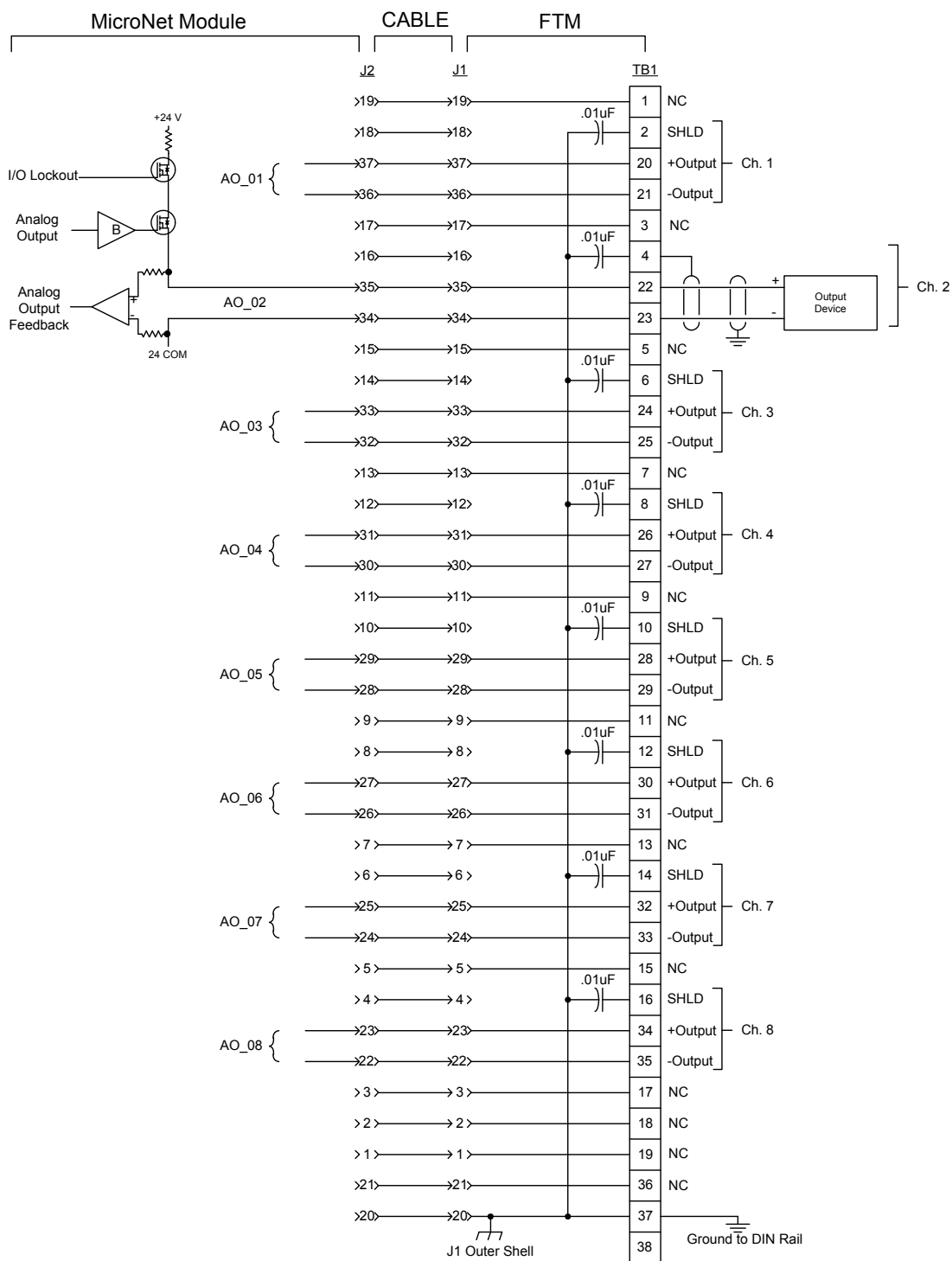

Figure 5-52. Analog Output Wiring for an 8 Chnl Voltage Output Module

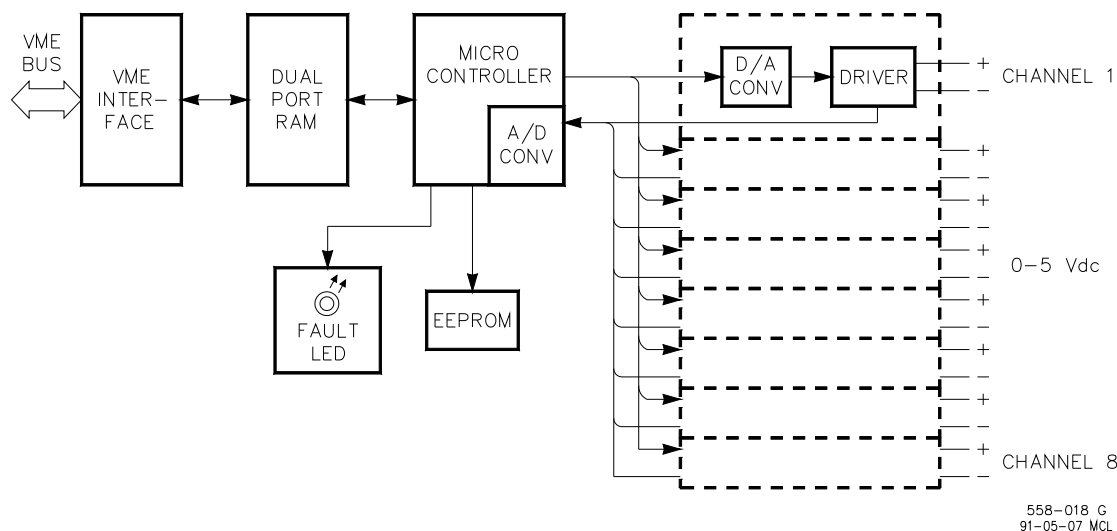

Figure 5-53. 8 Ch. Voltage Output (0–5 Vdc) Module Block Diagram

If an analog output is not functioning properly, verify the following:

1. Check that the cable is shielded and the shield is properly grounded per the Shields and Grounding section in Chapter 14.
2. Check the load resistance to ensure that it is not less than 500 ohms.
3. Check to ensure that the load wiring is isolated.
4. Check the wiring for a loose connection on the terminal blocks and disconnected or misconnected cables.
5. Disconnect the field wiring and check that the output is correct across the FTM terminals. If the output is correct, there is a problem with the field wiring.
6. If the other output channels on the 8 Ch. Voltage Output (0–5 Vdc) Module are also not working, check the fuse on the 8 Ch. Voltage Output (0–5 Vdc) Module. See instructions for module replacement in Chapter 15. This fuse is visible and can be changed through the bottom of the module. If the fuse is blown, fix the wiring problem and replace the fuse with a fuse of the same type and rating.
7. Check the software configuration to ensure that the output is configured properly.
8. After verifying all of the above, replace the 8 Ch. Voltage Output (0–5 Vdc) Module.
9. If replacing the module does not fix the problem, replace the FTM. See instructions for replacing the FTM in Chapter 15. The FTM does not contain any active components on the MPU inputs, so replacing it should be the last option.

5.16. 8Ch Voltage Output (0-10 Vdc) Module

5.16.1—Module Description

The 8 Ch. Voltage Output (0–10 Vdc) Module is the same as an 8 Ch. Voltage Output (0–5 Vdc) Module with different feedback gain to scale the output for 0–10 Vdc on each channel.



Figure 5-54. 8 Channel Voltage Output (0–10 Vdc) Module

5.16.2—Specification

Number of Channels:	8
Current range:	0 – 12.5 V
Maximum load resistance:	500 ohms min.
Analog Channel bandwidth:	500 Hz min.
Module interface:	VMEbus
Output update time:	1 ms
Resolution:	12 bit
Accuracy:	0.1% of full scale @ 25 °C
Maximum Drift:	50 ppm/degrees C
Status Indication:	RED LED - channel fault or board fault
Channel faults:	Output current monitored
Microcontroller faults:	system monitors a software watchdog
System faults:	All outputs are set to zero if MFT is lost.
Operating Temp:	0 to 70 °C
Isolation:	None

5.16.3—Installation

See 8 Ch. Voltage Output (0–5 Vdc) Module.

5.16.4—FTM Reference

See Chapter 12 for complete field wiring information for the 8 Ch. Voltage Output (0–10 Vdc) FTM. See Appendix A for part number Cross Reference for modules, FTMs, and cables.

5.16.5—Troubleshooting

See 8 Ch. Voltage Output (0–5 Vdc) Module.

5.17. Thermocouple Input Modules

There are two Thermocouple Input modules.

5.18. 8Ch TC (Fail Low) Module

5.18.1—Module Description

There are eight fully isolated thermocouple channels on this module. Each channel receives a signal from a thermocouple. These signals can be from an E, J, K, R, S, or T type thermocouple. The same module can read all types of thermocouples. The GAP application configuration determines the type of thermocouple each channel reads. If an open thermocouple wire is detected by the module, the output of the channel will ramp down to its minimum value. There is a 9th Channel used to measure the reference junction temperature of the junction between the thermocouple and the copper traces on the FTM. This measurement is used to calculate the thermocouple measurement temperature through the GAP application. This cold junction measurement is located on the FTM and utilizes an AD590 temperature sensor. If the actual cold junction in the field wiring occurs elsewhere, the temperature of that junction must be brought into the control as a thermocouple, RTD, or 4–20 mA input, and the application software must be configured to use the appropriate cold junction temperature. The thermocouple and cold junction input units (°C or °F) should be consistent in the application software.

The board performs on-line temperature compensation and hardware diagnostics. These modules have no potentiometers and require no calibration. A module may be replaced with another module of the same part number without any adjustment.



Figure 5-55. 8 Channel TC (Fail Low) Module

5.18.2—Specification

Number Channels: 8 double ended, fully isolated, thermocouple input channels
1 cold junction channel.

(Type E, J, K, R, S, and T thermocouples must conform to the common commercial specification published in the Annual Book of ASTM Standards with voltage predictions in line with N.I.S.T. Monograph 175 or ITS-90.)

Table 5-7. Thermocouple Types and ranges

T/C TYPE	LOW END °C (°F)	HIGH END °C (°F)
J	-40°C (-40°F)	1050°C (1922°F)
K	-40°C (-40°F)	1600°C (29125°F)
E	-40°C (-40°F)	800°C (1472°F)
R	-40°C (-40°F)	1750°C (3182°F)
S	-40°C (-40°F)	1750°C (3182°F)
T	-40°C (-40°F)	1050°C (1922°F)
CJ	-40°C (-40°F)	150°C (302°F)

Module interface:	VMEbus
Open thermocouple detection:	Fail Low
Output:	Linearized temperatures in °C
Resolution:	16 bit converter
Accuracy:	0.5% of full scale over the entire temperature range
Temperature Coefficient:	12 ppm/degree C
Isolation:	1500 Vac continuous (channel input to control common)
Input Impedance:	2 MΩ
CMRR:	-90 db
Status Indication:	RED LED - channel fault or board fault
Cold Junction Comp:	AD590L IC sensor 1% accuracy (Located on FTM)

5.18.3—Installation

The modules slide into card guides in the control's chassis and plug into the motherboard. The modules are held in place by two screws, one at the top and one at the bottom of the front panel. Also at the top and bottom of the module are two handles which, when toggled (pushed outward), move the modules out just far enough for the boards to disengage the motherboard connectors.

In a simplex system, each 8 Ch. TC (Fail Low) module is connected through one low Density analog cable to one TC Input FTM. All of the I/O are accessible on the FTM.

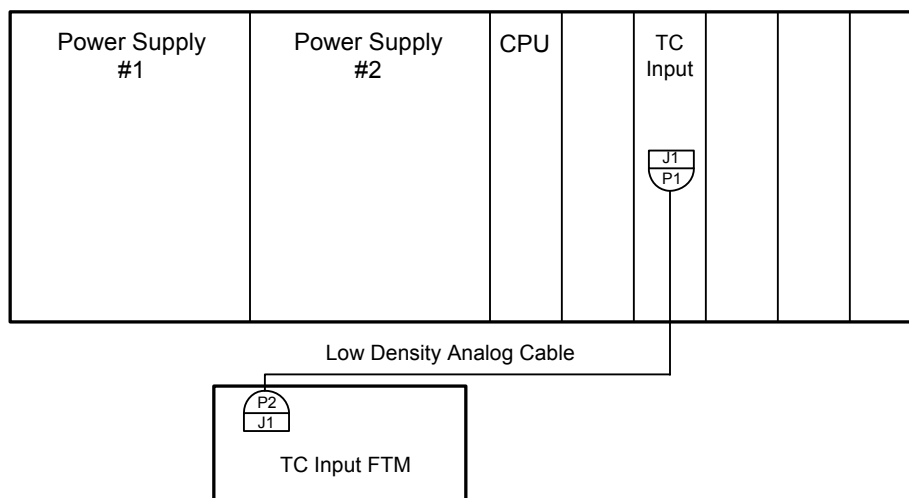

Figure 5-56. 8 Ch. TC (Fail Low) Module Configuration

See Figure 5-57 for Thermocouple field wiring connections.

5.18.4—FTM Reference

See Volume 2, Chapter 12 for TC Input FTM information. See Appendix A for proper Module, FTM, and cable part numbers.

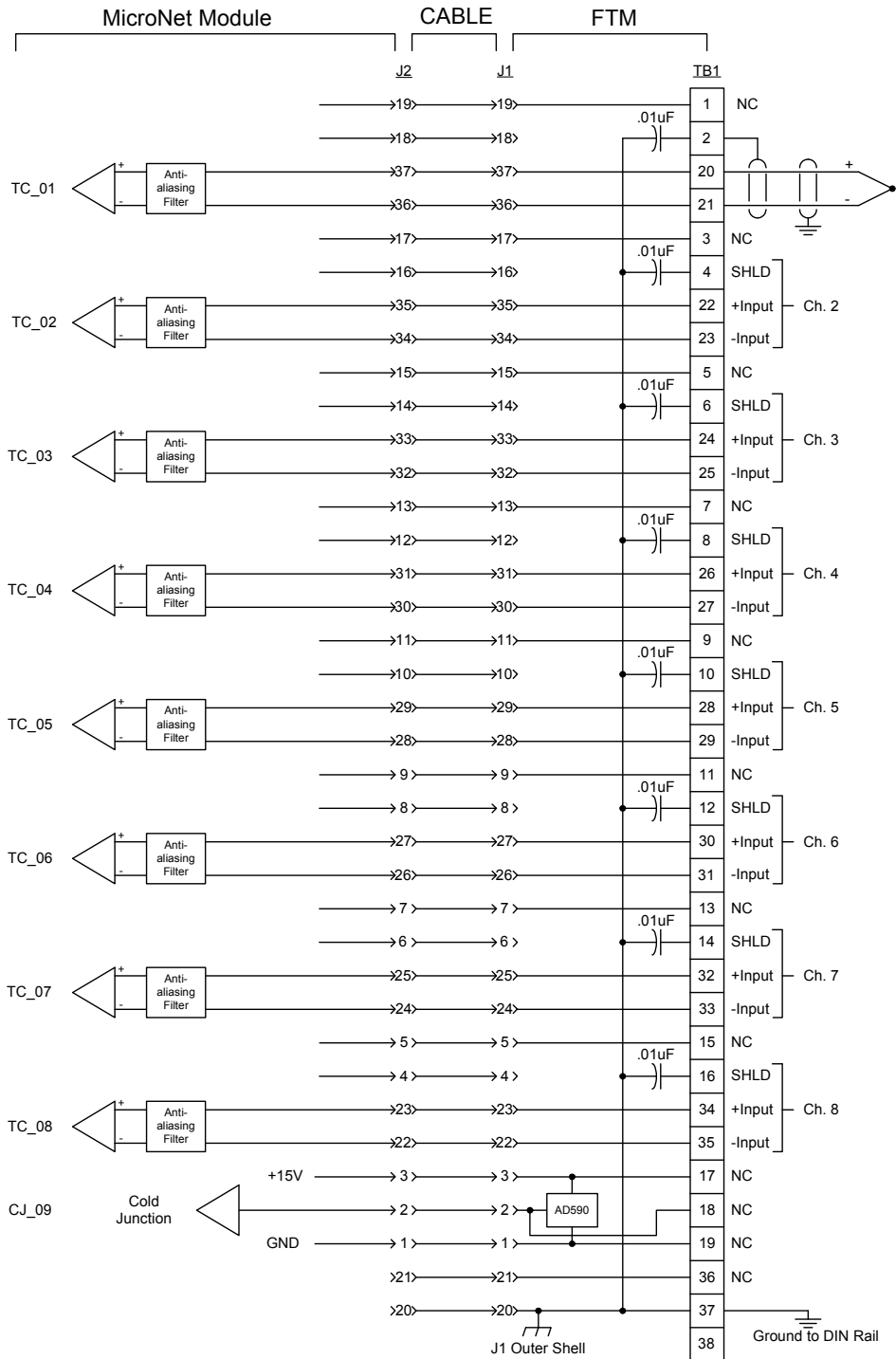

Figure 5-57. 8 Ch. TC Input (Fail Low) Module Field Wiring

5.18.5—Troubleshooting

The board performs on-line temperature compensation and hardware diagnostics. To do this, once per minute, it reads two known voltages for each channel. These values are checked against certain limits to determine if a hardware fault has occurred. These values are also used to determine software scaling constants used for temperature compensation. The MUX receives the thermocouple input and, under the control of the microcontroller, passes the value through the gain amplifier to the isolation amplifier. The output of the isolation amplifier goes to one input of the channel-selecting MUX.

This MUX, under control of the microprocessor, selects the channel to be read. The analog output of this MUX is converted to a digital value by the A/D converter, and passed to the microcontroller. The microcontroller uses a lookup table to linearize the thermocouple readings and stores the result in the Dual-Port RAM. The CPU can then access the values stored in Dual-Port RAM through the VME interface and bus. Upon detection of an open wire on the input, the channel will indicate a minimum scale reading. See Figure 5-58 for module block diagram.

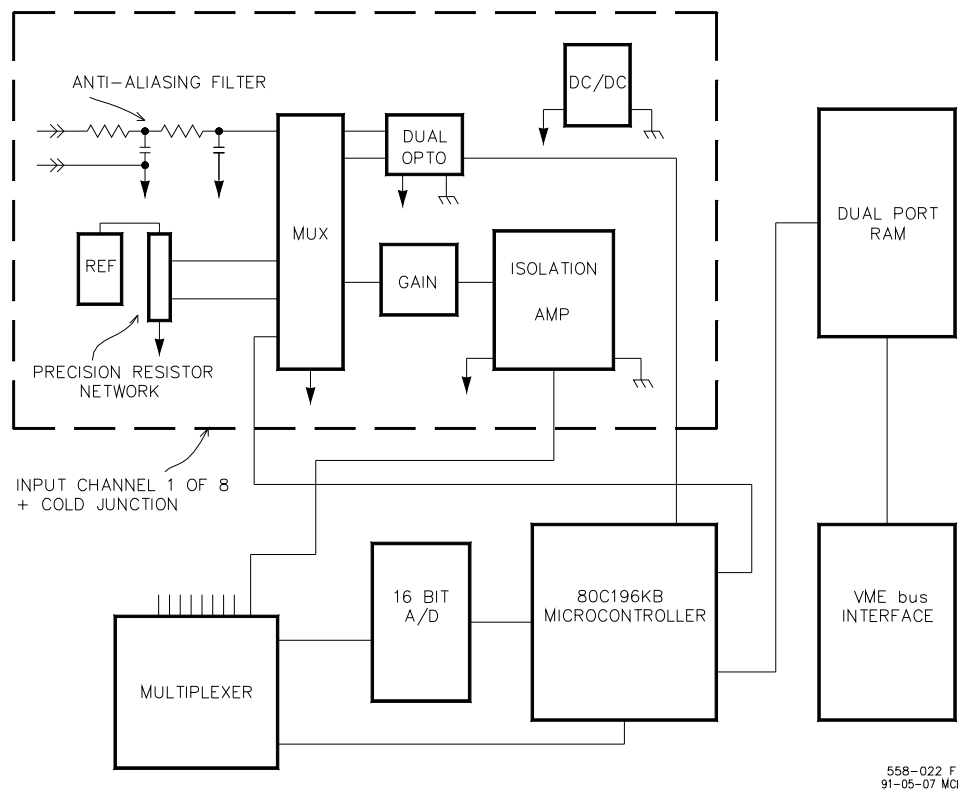

Figure 5-58. Thermocouple Input Block Diagram

During initialization, which occurs after every reset, the CPU turns the FAULT LEDs on. The CPU then tests each I/O module using diagnostic routines built into software. If the diagnostic test is not passed, the LED remains on. If the test is successful, the LED goes off.

During initialization of the module, the module's micro-controller turns the LED off after power-on self-tests have passed and the CPU has initialized the module.

The CPU also tells this module in which rate group each channel is to run, as well as special information. At run time, the CPU then periodically broadcasts a "key" to all I/O cards, telling them which rate groups are to be updated at that time. Through this initialization/key broadcast system, each I/O module handles its own rate-group scheduling with minimal CPU intervention.

This module also has on-card on-line fault detection and automatic calibration/compensation. Each input channel has its own precision voltage reference. Once per minute, while not reading inputs, the on-board microcontroller reads this reference. The microcontroller then uses this data read from the voltage reference for both fault detection and automatic temperature compensation/calibration.

Limits have been set for the expected readings when the on-board microcontroller reads each voltage reference. If the reading obtained is outside these limits, the system determines that the input channel, A/D converter, or the channel's precision-voltage reference is not functioning properly. If this happens, the micro-controller flags that channel as having a fault condition. The CPU will then take whatever action the application engineer has provided for in the application program.

The readings from the precision-voltage reference are also used for on-line temperature compensation and automatic calibration for the module. The readings of the precision-voltage reference, obtained from the A/D converter, are used by the microcontroller to determine software scaling- and offset-constants for each channel. These scaling-and offset-constants are respectively multiplied by and added to each channel reading to provide corrected channel readings. The module therefore includes no potentiometers and needs no calibration.

Each I/O module has a fuse on it; this fuse is visible and can be changed through a cutout in the plastic cover of the module. If this fuse is blown, replace it with a fuse of the same type and size.

Troubleshooting Guide

If a Thermocouple input is not functioning properly, verify the following:

1. Check that the cable is shielded and the shield is properly grounded per the Shields and Grounding section in Chapter 14.
2. Measure the input voltage on the terminal block. It should be in the range of appropriate millivolt signal.
3. Verify that there are no or minimal AC components to the Analog Input signal. AC components can be caused by improper shielding. Thermocouple inputs are extremely sensitive to signal fluctuations.
4. If the input is reading minimum range, look for a loose connection at the terminal blocks and disconnected or misconnected cables.
5. If all the temperature measurements are offset by a fixed amount, check for proper cold junction location. Replace the FTM.
6. Check the software configuration to ensure that the input is configured properly. Ensure that the proper thermocouple type is selected.
7. After verifying all of the above, replace the 8 Ch. TC module.

5.19. 8Ch TC (Fail High) Module

5.19.1—Module Description

There are two types of the Thermocouple (Fail High) modules. The standard module is the same as the 8 Ch. TC (Fail Low) Module except when a failure is detected, the signal will indicate a full scale value. The Non-standard 8 Ch. TC (Fail High) module has replaced the type "E" table with a type "N" table and also fails high when a failure is detected.



Figure 5-59. 8 Channel TC (Fail High) Module

5.19.2—Specification

Number Channels:8 double ended, fully isolated, thermocouple input channels
One cold junction channel.

(Type E, J, K, N, R, S, and T thermocouples must conform to the common commercial specification published in the Annual Book of ASTM Standards with voltage predictions in line with N.I.S.T. Monograph 175 or ITS-90.)

Table 5-8. Thermocouple Types and ranges

T/C TYPE	LOW END °C (°F)	HIGH END °C (°F)
J	-40°C (-40°F)	1050°C (1922°F)
K	-40°C (-40°F)	1600°C (29125°F)
E	-40°C (-40°F)	800°C (1472°F)
R	-40°C (-40°F)	1750°C (3182°F)
S	-40°C (-40°F)	1750°C (3182°F)
T	-40°C (-40°F)	1050°C (1922°F)
N	-40°C (-40°F)	1051°C (1925°F)
CJ	-40°C (-40°F)	150°C (302°F)

Module interface: VMEbus
 Open thermocouple detection: Fail Low
 Output: Linearized temperatures in °C
 Resolution: 16 bit converter
 Accuracy: 0.5% of full scale over the entire temperature range
 Temperature Coefficient: 12 ppm/degree C
 Isolation: 1500 Vac continuous (channel input to control common)
 Input Impedance: 2 MΩ
 CMRR: -90 db
 Status Indication: RED LED - channel fault or board fault
 Cold Junction Comp: AD590L IC sensor 1% accuracy

5.19.3—Installation

See 8 Ch. TC (Fail Low) Module.

5.19.4—FTM Reference

See Volume 2, Chapter 12 for complete field wiring information for the 8 Ch. TC (Fail High) FTM. See Appendix A for part number Cross Reference for modules, FTMs, and cables.

5.19.5—Troubleshooting

See 8 Ch. TC (Fail Low) Module.

5.20. RTD Input Modules

There are four RTD (Resistance Temperature Device) Input modules.

5.21. 8Ch RTD Input (10 ohm)

5.21.1—Module Description

The eight channels of this module are semi-isolated. The channels are isolated from the control common but not from each other. Each channel receives a signal from an RTD. This signal must be from a 10Ω Copper RTD with the following temperature to Resistance relationship:

$$T=(R*25.95)-(234.5)$$

Where R= resistance of copper RTD (ohms)
T= °C

The board performs on-line temperature compensation and hardware diagnostics. These modules have no potentiometers and require no calibration. A module may be replaced with another module of the same part number without any adjustment.



Figure 5-60. 8 Channel RTD Input Module (10 ohm)

5.21.2—Specification

Number of Channels:	8 semi-isolated, RTD channels
Input Type:	3 wire
(Must conform to 10 ohm copper RTD temperature/resistance relationship (Alpha = .00427))	
Temperature range:	-40 to +300 °C
Module interface:	VMEbus
Output:	Linearized temperatures in °C
Resolution:	14 bit converter
Accuracy:	0.5% of full scale over the entire temperature range
Temperature Coefficient:	12 ppm/degrees C
Isolation:	1500 Vac continuous (input channels to control common, not channel to channel)
Input Impedance:	2.2 MΩ
CMRR:	-90 db
Status Indication:	RED LED - channel fault or board fault
Excitation:	4 mA

5.21.3—Installation

The modules slide into card guides in the control's chassis and plug into the motherboard. The modules are held in place by two screws, one at the top and one at the bottom of the front panel. Also at the top and bottom of the module are two handles which, when toggled (pushed outward), move the modules out just far enough for the boards to disengage the motherboard connectors.

In a simplex system, each 8Ch RDT Input Module is connected through one low Density analog cable to one Analog Input FTM. All of the I/O are accessible on the FTM.

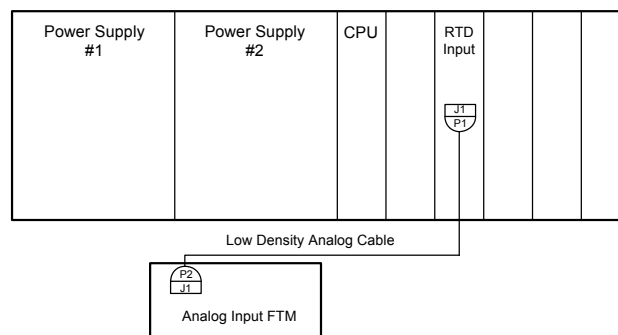

Figure 5-61. 8Ch RTD Module Configuration

See Figure 5-55 for RTD field wiring connections.

5.21.4—FTM Reference

See Chapter 13 for complete field wiring information for the 8Ch RTD Input (10 ohm) FTM. See Appendix A for part number Cross Reference for modules, FTMs, and cables.

5.21.5—Troubleshooting

The board performs on-line temperature compensation and hardware diagnostics. To do this, once per minute, it reads two known voltages for each channel. These values are checked against certain limits to

determine if a hardware fault has occurred. These values are also used to determine software scaling constants used for temperature compensation. The MUX receives the RTD input and, under the control of the microcontroller, passes the value through the gain amplifier to the isolation Amplifier. The gain amplifier introduces the proper gain for the type of RTD used. The output of the isolation amplifier goes to one input of the channel-selecting MUX.

This MUX, under control of the microprocessor, selects the channel to be read. The analog output of this MUX is converted to a digital value by the A/D converter, and passed to the microcontroller. The microcontroller uses a lookup table to linearize the RTD reading and stores the result in the Dual-Port RAM. The CPU can then access the values stored in Dual-Port RAM through the VME interface and bus. See Figure 9-56 for module block diagram.

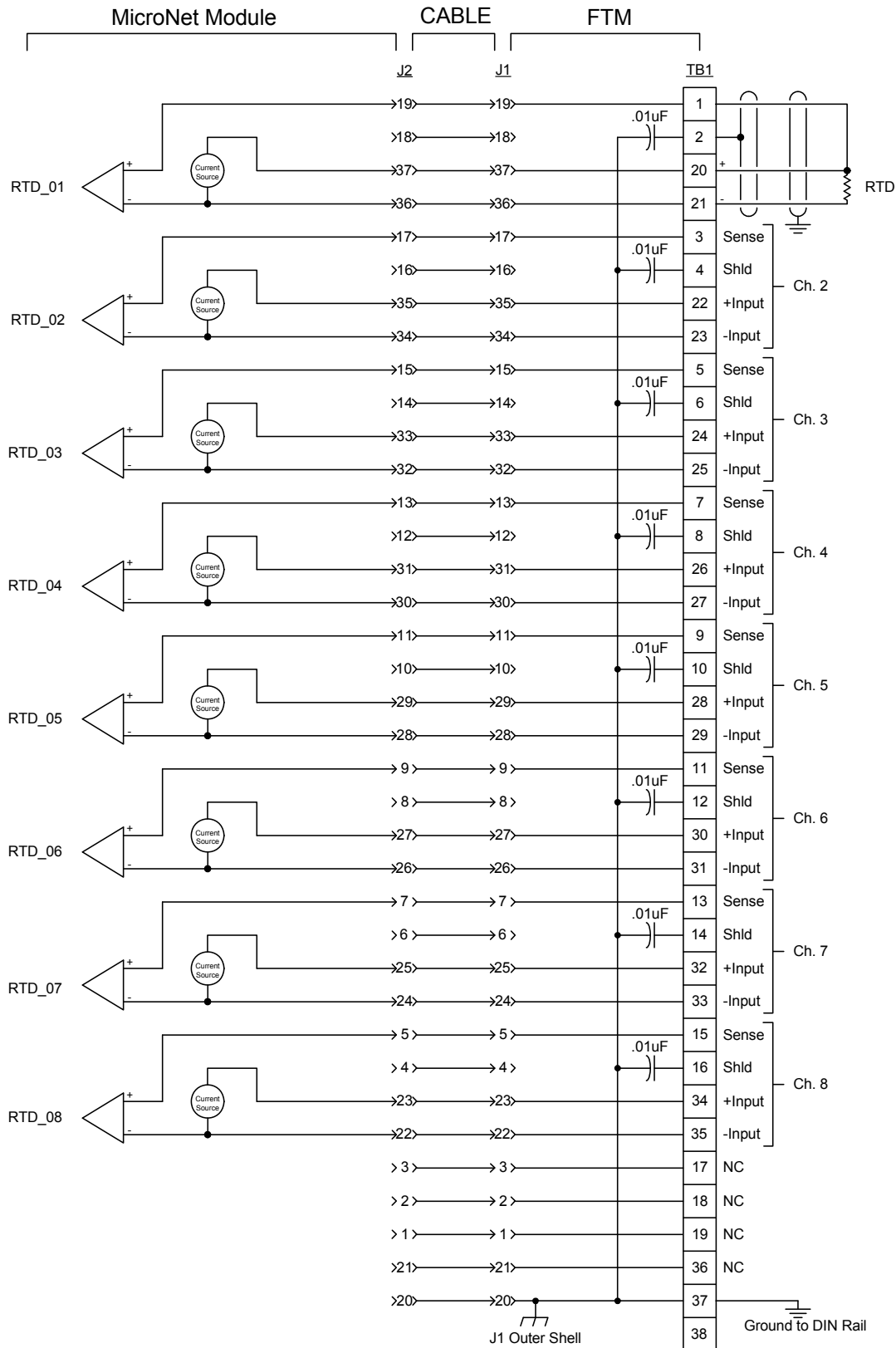

Figure 5-62. 8Ch RTD Input Module Field Wiring

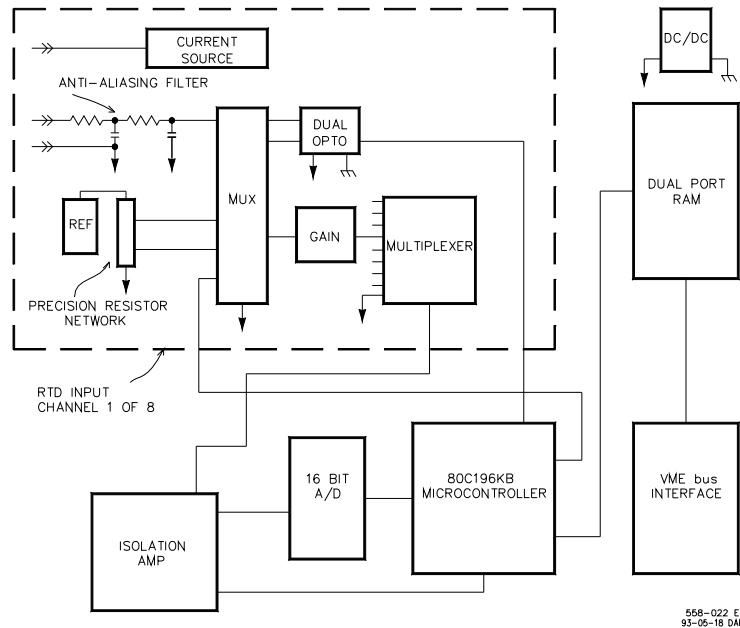

Figure 5-63. RTD Input Block Diagram

During initialization, which occurs after every reset, the CPU turns the FAULT LEDs on. The CPU then tests each I/O module using diagnostic routines built into software. If the diagnostic test is not passed, the LED remains on. If the test is successful, the LED goes off.

During initialization of the module, the module's micro-controller turns the LED off after power-on self-tests have passed and the CPU has initialized the module.

The CPU also tells this module in which rate group each channel is to run, as well as special information. At run time, the CPU then periodically broadcasts a "key" to all I/O cards, telling them which rate groups are to be updated at that time. Through this initialization/key broadcast system, each I/O module handles its own rate-group scheduling with minimal CPU intervention.

This module also has on-card on-line fault detection and automatic calibration/compensation. Each input channel has its own precision voltage reference. Once per minute, while not reading inputs, the on-board microcontroller reads this reference. The microcontroller then uses this data read from the voltage reference for both fault detection and automatic temperature compensation/calibration.

Limits have been set for the expected readings when the on-board microcontroller reads each voltage reference. If the reading obtained is outside these limits, the system determines that the input channel, A/D converter, or the channel's precision-voltage reference is not functioning properly. If this happens, the micro-controller flags that channel as having a fault condition. The CPU will then take whatever action the application engineer has provided for in the application program.

The readings from the precision-voltage reference are also used for on-line temperature compensation and automatic calibration for the module. The readings of the precision-voltage reference, obtained from the A/D converter, are used by the microcontroller to determine software scaling- and offset-constants for each channel. These scaling-and offset-constants are respectively multiplied by and added to each channel reading to provide corrected channel readings. The module therefore includes no potentiometers and needs no calibration.

Each I/O module has a fuse on it; this fuse is visible and can be changed through a cutout in the plastic cover of the module. If this fuse is blown, replace it with a fuse of the same type and size.

Troubleshooting Guide

If an RTD input is not functioning properly, verify the following:

1. Check that the cable is shielded and the shield is properly grounded per the shields and grounding section in Chapter 15, installation.
2. Measure the input voltage on the terminal block (Sense to – input). It should be in the range generated by a 4 mA current source across the RTD.
3. Verify that there are no or minimal AC components to the Analog Input signal. AC components can be caused by improper shielding.
4. Check for proper connection of the sense line.
5. Check the software configuration to ensure that the input is configured properly. Ensure that the proper RTD is selected. Ensure that the Lag input Tau is set to at least 0.200.
6. If replacing the module does not fix the problem, replace the FTM. See the instructions in Chapter 15, Installation, for replacing the FTM. The FTM contains only traces and a few discrete components, so failure is extremely unlikely.

5.22. 8Ch RTD Input (100 ohm)

5.22.1—Module Description

The eight channels of this module are semi-isolated. The channels are isolated from the control common but not from each other. Each channel receives a signal from an RTD. This signal must be from a 100 Ω Platinum RTD (European or American curve). There are two types of 100 ohm modules. The standard module has the same temperature ranges for the American and European curves (–40 to +450 °C). The high temperature module has a temperature range of –40 to +450 °C for the American curve and –40 to +645 °C for the European curve.



Figure 5-64. 8 Channel RTD Input Module (100 ohm)

5.22.2—Specification

Number of Channels: 8 semi-isolated, RTD channels
Input Type: 3 wire

(Must conform to (Deutsche Institut für Normung) DIN standard for 100 ohm European curve (Alpha = .00385) or American curve 100 ohm curve (Alpha = .00392))

Temperature ranges

Standard module:	-40 to +450 °C (100 ohm platinum, American, European)	
High Temp Module:	-40 to +645 °C (100 ohm platinum, European)	
	-40 to +450 °C (100 ohm platinum, American)	
Excitation:	2 mA	
Module interface:	VMEbus	
Output:	Linearized temperatures in °C	
Resolution:	14 bit converter	
Accuracy:	0.5% of full scale over the entire temperature range	
Temperature Coefficient:	12 ppm/degree C	
Isolation:	1500 Vac continuous (input channels to control common, not channel to channel)	
Input Impedance:	2.2 MΩ	
CMRR:	-90 db	
Status Indication:	RED LED - channel fault or board fault	

5.22.3—Installation

See 8Ch RTD Input (10 ohm) Module.

5.22.4—FTM Reference

See Chapter 13 for complete field wiring information for the 8Ch RTD Input (100 ohm) FTM. See Appendix A for part number Cross Reference for modules, FTMs, and cables.

5.22.5—Troubleshooting

See 8Ch RTD Input (10 ohm) Module.

5.23. 8Ch RTD Input (200 ohm)**5.23.1—Module Description**

The eight channels of this module are semi-isolated. The channels are isolated from the control common but not from each other. Each channel receives a signal from an RTD. This signal must be from a 200Ω Platinum RTD (European or American curve).



Figure 5-65. 8 Channel RTD Input Module (200 ohm)

5.23.2—Specification

Number of Channels: 8 semi-isolated, RTD channels
 Input Type: 3 wire

(Must conform to (Deutsche Institut für Normung) DIN standard for 200 ohm European curve (Alpha = .00385) or American curve 200 ohm curve (Alpha = .00392))

Temperature ranges: -40 to +450 °C (200 ohm platinum, American, European)
 Excitation: 1 mA
 Module interface: VMEbus
 Output: Linearized temperatures in °C
 Resolution: 14 bit converter
 Accuracy: 0.5% of full scale over the entire temperature range
 Temperature Coefficient: 12 ppm/degree C
 Isolation: 1500 Vac continuous (input channels to control common, not channel to channel)
 Input Impedance: 2.2 MΩ
 CMRR: -90 db
 Status Indication: RED LED - channel fault or board fault

5.23.3—Installation

See 8Ch RTD Input (10 ohm) Module.

5.23.4—FTM Reference

See Chapter 13 for complete field wiring information for the 8Ch RTD Input (200 ohm) FTM. See Appendix A for part number Cross Reference for modules, FTMs, and cables.

5.23.5—Troubleshooting

See 8Ch RTD Input (10 ohm) Module.

5.24. 8Ch RTD Input (500 ohm)

5.24.1—Module Description

The eight channels of this module are semi-isolated. The channels are isolated from the control common but not from each other. Each channel receives a signal from an RTD. This signal must be from a 500 Ω Platinum RTD (European or American curve).



Figure 5-66. 8 Channel RTD Input Module (500 ohm)

5.24.2—Specification

Number of Channels: 8 semi-isolated, RTD channels
 Input Type: 3 wire

(Must conform to (Deutsche Institut für Normung) DIN standard for 500 ohm European curve (Alpha = .00385) or American curve 500 ohm curve (Alpha = .00392))

Temperature ranges: -40 to +450 °C (500 ohm platinum, American, European)
 Excitation: 400 a
 Module interface: VMEbus
 Output: Linearized temperatures in °C
 Resolution: 14 bit converter
 Accuracy: 0.5% of full scale over the entire temperature range
 Temperature Coefficient: 12 ppm/degree C
 Isolation: 1500 Vac continuous (input channels to control common, not channel to channel)

Input Impedance: 2.2 MΩ
 CMRR: -90 db
 Status Indication: RED LED - channel fault or board fault

5.24.3—Installation

See 8Ch RTD Input (10 ohm) Module.

5.24.4—FTM Reference

See Chapter 13 for complete field wiring information for the 8Ch RTD Input (500 ohm) FTM. See Appendix A for part number Cross Reference for modules, FTMs, and cables.

5.24.5—Troubleshooting

See 8Ch RTD Input (10 ohm) Module.

5.25. 4Ch MPU/Proximity Module

There are many configurations of the MPU/Proximity Module. See Appendix A for the various part numbers.

5.24.1—Module Description

This module has four speed inputs that can be configured as either transformer isolated MPU inputs or non-isolated proximity inputs. The configuration of MPU and proximity inputs is dependent on the part number.

These modules have no potentiometers and require no calibration. A module may be replaced with another module of the same part number without any adjustment.

IMPORTANT

For compatibility with the CPU5200 (Cyber-Security), the minimum required revisions of the 4Ch MPU/Proximity modules are shown in the chart below:

Table 5-9. 4Ch. MPU/Proximity Modules Compatibility with CPU5200

Woodward Item Number	Revision required for use with CPU5200 (Cyber-Security)
5463-787	Revision P and later
5464-015	Revision M and later
5464-414	Revision H and later
5464-658	Revision K and later
5464-659	Revision H and later
5464-834	Revision K and later
5464-844	Revision G and later
5464-850	Revision G and later
5466-404	Revision D and later
5466-405	Revision C and later

8.29.2—Specification

Number Channels:	4
Input Type:	MPU/Proximity Detector (factory selected by part number)
Input Frequency Range:	MPU: 50 Hz to 25 KHz Prox: 0.04 Hz to 2 KHz
Input Amplitude:	MPU: 1 Vrms min, 25 Vrms max, Freq > 20 Hz Prox: 10 mA
Input Impedance:	MPU: 2000 Ω Prox: 2000 Ω
Isolation Voltage:	MPU: 500 Vrms Prox: None
Resolution:	16 bits
Speed Accuracy (max):	0.0015% of range per LSB
Temperature drift:	0.01% over temperature range
Derivative Accuracy (max):	1 ppm/°C
Speed Filter:	0.10% of range (p-p)
Derivative Filter:	5-10,000 ms (2 real poles)
Acceleration Limit:	5-10,000 ms (1 pole + speed filter)
Operating Temperature:	1-10,000 percent/second -15 to +55 °C



Figure 5-67. 4 Channel MPU/Proximity Module

8.29.3—Installation

The modules slide into card guides in the control's chassis and plug into the motherboard. The modules are held in place by two screws, one at the top and one at the bottom of the front panel. Also at the top and bottom of the module are two handles which, when toggled (pushed outward), move the modules out just far enough for the boards to disengage the motherboard connectors.

In a simplex system, each 4 Ch. Speed Module is connected through one low Density analog cable to one Analog Input FTM. All of the I/O are accessible on the FTM.

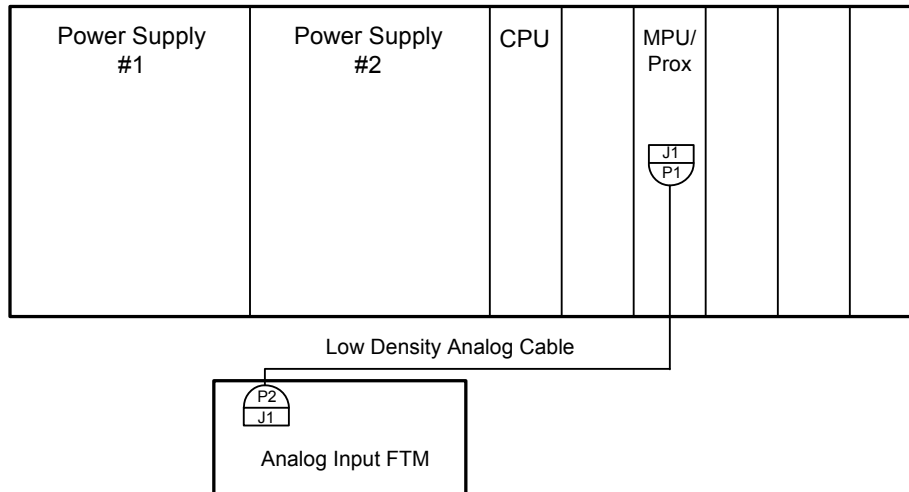

Figure 5-68. 4 Ch. MPU/Proximity Module

Any of the module's four speed channels accept passive magnetic pickup units (MPUs) or proximity probes. The number of MPU and proximity inputs per module is determined by the position of jumpers internal to the module. These jumpers are factory set. The part number of the module will determine the ratio of MPU to Proximity inputs. Each speed input channel can only accept one MPU or one proximity probe. See Appendix A for desired part number of modules.

A proximity probe may be used to sense very low speeds. With a proximity probe, speed can be sensed down to 0.5 Hz. When interfacing to open collector type proximity probes, a pull-up resistor is required between the supplied proximity probe voltage and the proximity probe input to the FTM. See Figure 7-62 for MPU and proximity probe wiring examples.

IMPORTANT

It is not recommended that gears mounted on an auxiliary shaft coupled to the rotor be used to sense speed. Auxiliary shafts tend to turn more slowly than the rotor (reducing speed sensing resolution) and have coupling gear backlash, resulting in less than optimum speed control. For safety purposes, it is also not recommended that the speed sensing device sense speed from a gear coupled to a mechanical drive side of a system's rotor coupling.

8.29.4—FTM Reference

See Chapter 12 for complete field wiring information for the 4 Ch. MPU/Proximity FTM. See Appendix A for part number Cross Reference for modules, FTMs, and cables.

8.29.5—Troubleshooting

Speed ranges are selected from the GAP and the signal is pre-scaled accordingly. The pre-scaled signal then goes to a counter where the period of the signal is measured. The Digital Signal Processor samples the counter's values every 100 microseconds and performs a divide to generate a digital speed signal.

Every 100 microseconds a digital-filter algorithm is executed to average the speed values in order to improve speed-sensor resolution at input frequencies greater than 200 Hz. This digital filter also provides a derivative output.

Once every rate time (5-200 ms typically), the latest speed and derivative information is moved to the Dual-Port RAM for access by the CPU module.

During initialization, which occurs after every reset, the CPU turns the FAULT LEDs on. The CPU then tests each I/O module using diagnostic routines built into software. If the diagnostic test is not passed, the LED remains on. If the test is successful, the LED goes off.

During initialization of the module, the module's micro-controller turns the LED off after power-on self-tests have passed and the CPU has initialized the module.

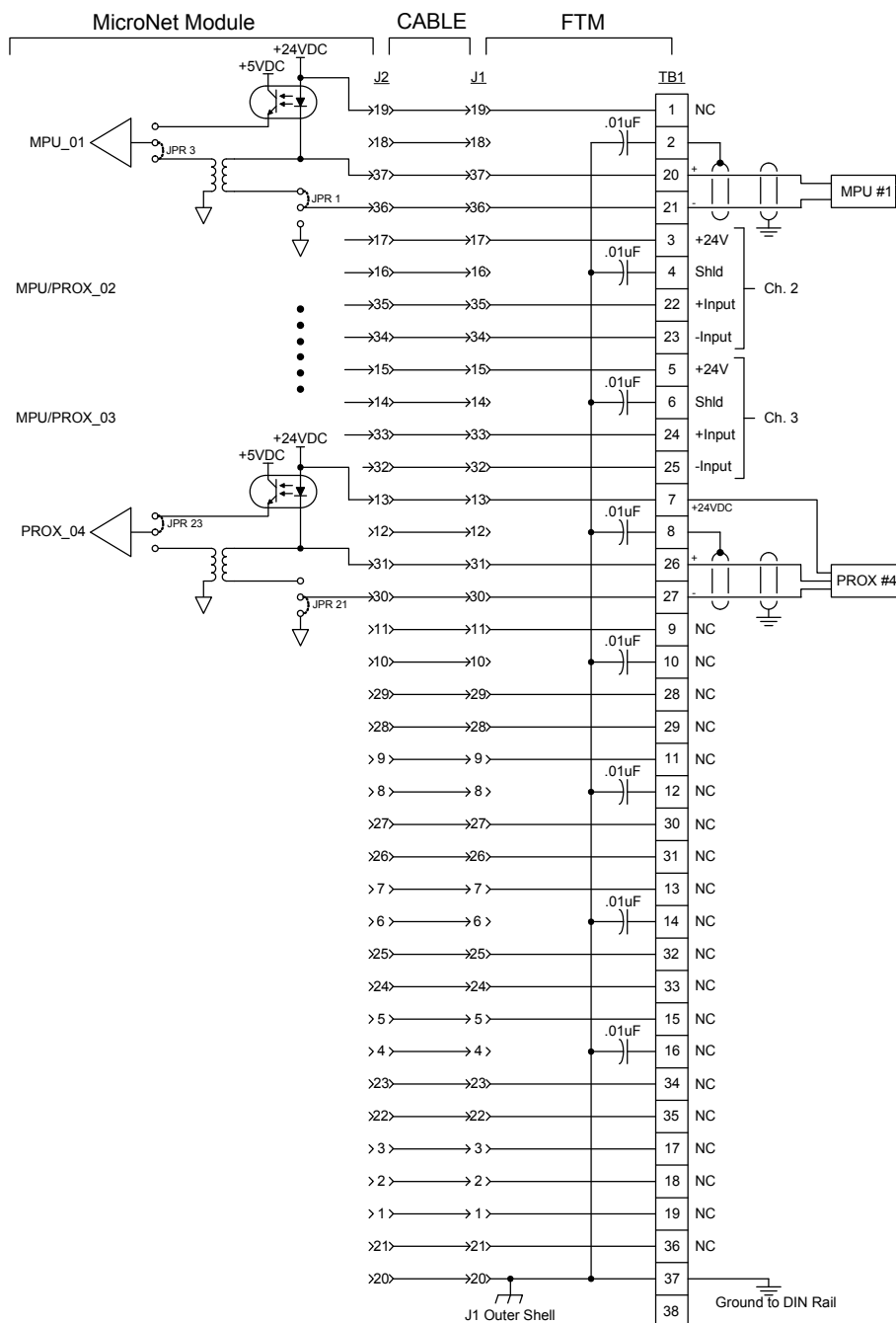

Figure 5-69. MPU and Proximity Probe Interface Wiring

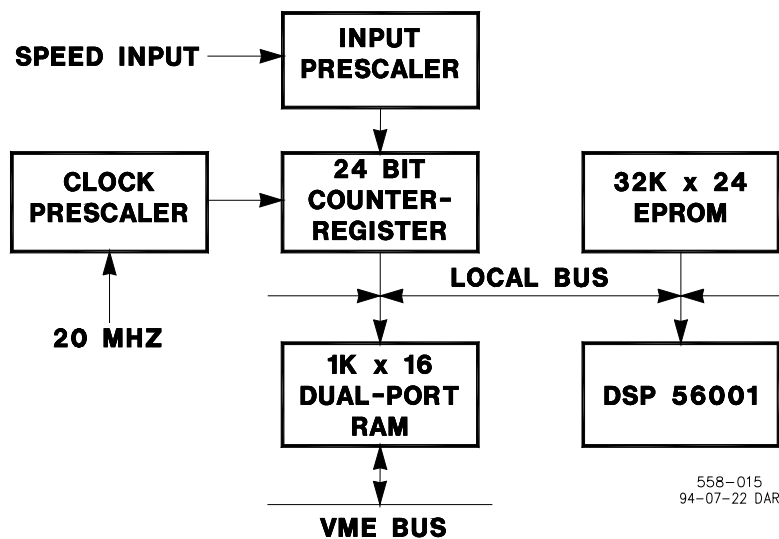

Figure 5-70. Digital Speed Sensor Module Block Diagram

The CPU also tells this module in which rate group each channel is to run, as well as special information. At run time, the CPU then periodically broadcasts a "key" to all I/O cards, telling them which rate groups are to be updated at that time. Through this initialization/key broadcast system, each I/O module handles its own rate-group scheduling with minimal CPU intervention.

Each I/O module has a fuse on it; this fuse is visible and can be changed through a cutout in the plastic cover of the module. If this fuse is blown, replace it with a fuse of the same type and size.

Troubleshooting Guide

MPUs. If a magnetic pickup input is not functioning properly, verify the following:

1. Check that the cable is shielded and the shield is properly grounded per the Shields and Grounding section in Chapter 14.
2. Measure the input voltage on the terminal block. It should be in the range of 1-25 VRMS.
3. Verify that the signal waveform is clean and void of double zero crossings.
4. Verify that no ground connection exists and that the resulting 60 Hz signal is absent.
5. Measure the frequency. It should be in the range of 50 Hz - 25 kHz.
6. Check the wiring. Look for a loose connection at the terminal blocks and disconnected or misconnected cables.
7. Check the software configuration to ensure that the input is configured properly.
8. If the readings are incorrect on several channels of the module, replace the Speed module.
9. If replacing the module does not fix the problem, replace the FTM. See instructions for replacing the FTM in Chapter 15. The FTM does not contain any active components on the MPU inputs, so replacing it should be the last option.

Proximity Probes

If a proximity probe input is not functioning properly, verify the following:

1. Check that the cable is shielded and the shield is properly grounded per the Shields and Grounding section in Chapter 14.
2. Measure the input voltage on the terminal block. It should be in the range of 3.5 - 24 V_{peak}.
3. Verify that the signal waveform is clean and void of double zero crossings.
4. Verify that no ground connection exists and that the resulting 60 Hz signal is absent.
5. Measure the frequency. It should be in the range of 0.5 Hz to 25 kHz.
6. Check the wiring. Look for a loose connection at the terminal blocks, disconnected or misconnected cables.
7. Check the software configuration to ensure that the input is configured properly.
8. If the readings are incorrect on several channels of the Speed module, replace the Speed module.
9. If replacing the module does not fix the problem, replace the FTM. See instructions for replacing the FTM in Chapter 15.

Chapter 6.

Actuator Modules

6.1. Four Channel Actuator Module

6.1.1—Module Description

This Actuator Driver module receives digital information from the CPU and generates four proportional actuator-driver signals. These signals are proportional and their maximum range is 0 to 25 mAdc or 0 to 200 mAdc.

Figure 9-5 is a block diagram of the four-channel Actuator Driver module. The system writes output values to dual-port memory through the VME-bus interface. The microcontroller scales the values using calibration constants stored in EEPROM, and schedules outputs to occur at the proper time.

The microcontroller monitors the output voltage and current of each channel and alerts the system of any channel and load faults. The system can individually disable the current drivers. If a fault is detected which prevents the module from operating, by either the microcontroller or the system, the FAULT LED will illuminate.

This module requires no calibration; an actuator may be replaced with a like actuator without any module or software adjustment.



Figure 6-1. Four Channel Actuator Driver Module

6.1.2—Module Specification

Output Current Ranges:	0–25 mA, 0–200 mA
Resolution:	12 bits
Accuracy @ 25 °C:	0.1% of full scale
Drift:	150 ppm/°C
Maximum Actuator Resistance:	45 Ω @ 200 mA, 360 Ω @ 25 mA

Maximum Actuator Inductance: 1 H
 Dither: Tunable amplitude, 25 Hz square wave
 Analog Driver Bandwidth: 50 Hz minimum

Fault Detection:

Load Faults: Module monitors actuator impedance
 Driver Faults: Actuator current is interrupted if fault is detected
 Microcontroller Faults: System monitors a software watchdog
 System Faults: Actuator current is interrupted if communications with CPU are lost
 Shutdowns: Current in each channel may be individually interrupted

6.1.3—Installation

The modules slide into card guides in the control’s chassis and plug into the motherboard. The modules are held in place by two screws, one at the top and one at the bottom of the front panel. Also at the top and bottom of the module are two handles which, when toggled (pushed outward), move the modules out just far enough for the boards to disengage the motherboard connectors.

6.1.4—FTM Reference

See Chapter 12 for complete field wiring information for the Four Channel Actuator Module FTM. See Appendix A for part number cross reference for modules, FTMs, and cables.

6.1.5—Troubleshooting

Each I/O module has a red fault LED, which indicates the status of the module. This LED will help with troubleshooting if the module should have a problem. A solid red LED indicates that the actuator controller is not communicating with the CPU module. Flashing red LEDs indicate an internal problem with the module, and module replacement is recommended.

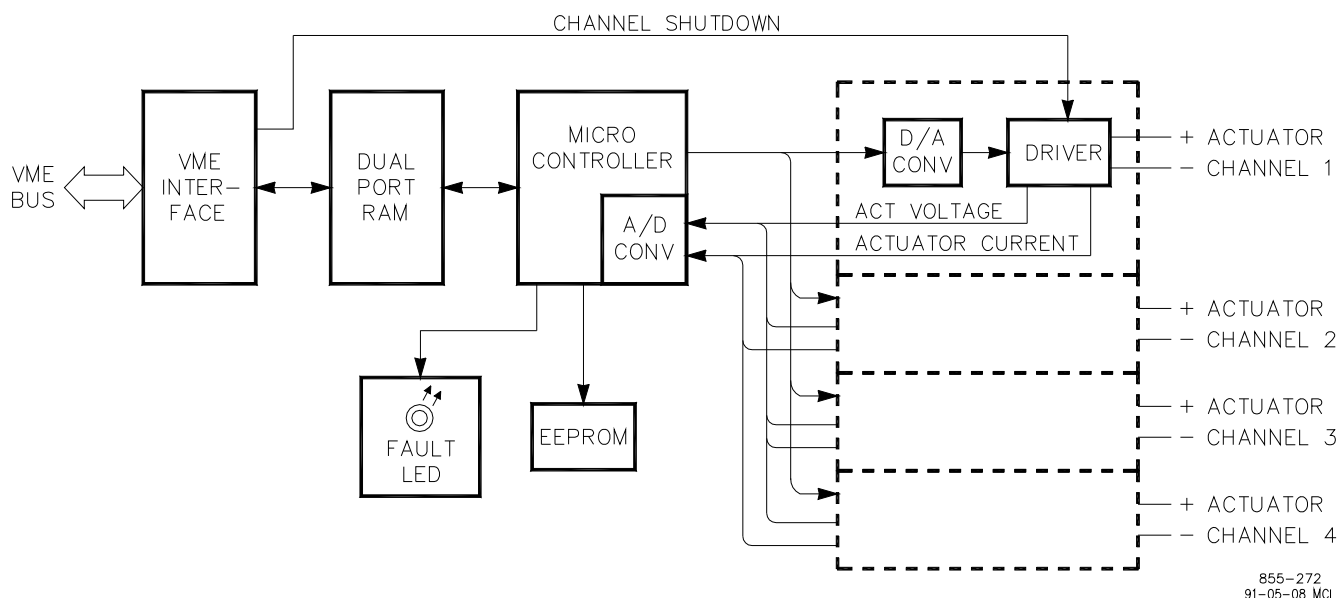

Figure 6-2. Four Channel Actuator Driver Module Block Diagram

855-272
 91-05-08 MCL

6.2. EM/TM Position Controller

6.2.1—Module Description

Figure 9-12 is a block diagram of the Position Controller Module (PCM). The microcontroller executes a position controller which receives a reference input from the CPU across the VME bus. It receives a feedback input from a remote driver via a serial link. The controller output is sent to the remote driver serially. Shutdown, reset, and fault signals are passed between the PCM and the remote driver using discrete lines.

The feedback input from the remote driver is a 16 bit value from the digitized output of a resolver. This gives the PCM the ability to control position with high accuracy and resolution. Consequently, the PCM is used primarily with Dry Low Emissions (DLE) systems or other systems where high accuracy is required.

The PCM can be used with various remote drivers as shown by Figure 6-4. For more information on using the position controller module with specific remote drivers, see the remote driver manual.



Figure 6-3. EM/TM Position Control Module

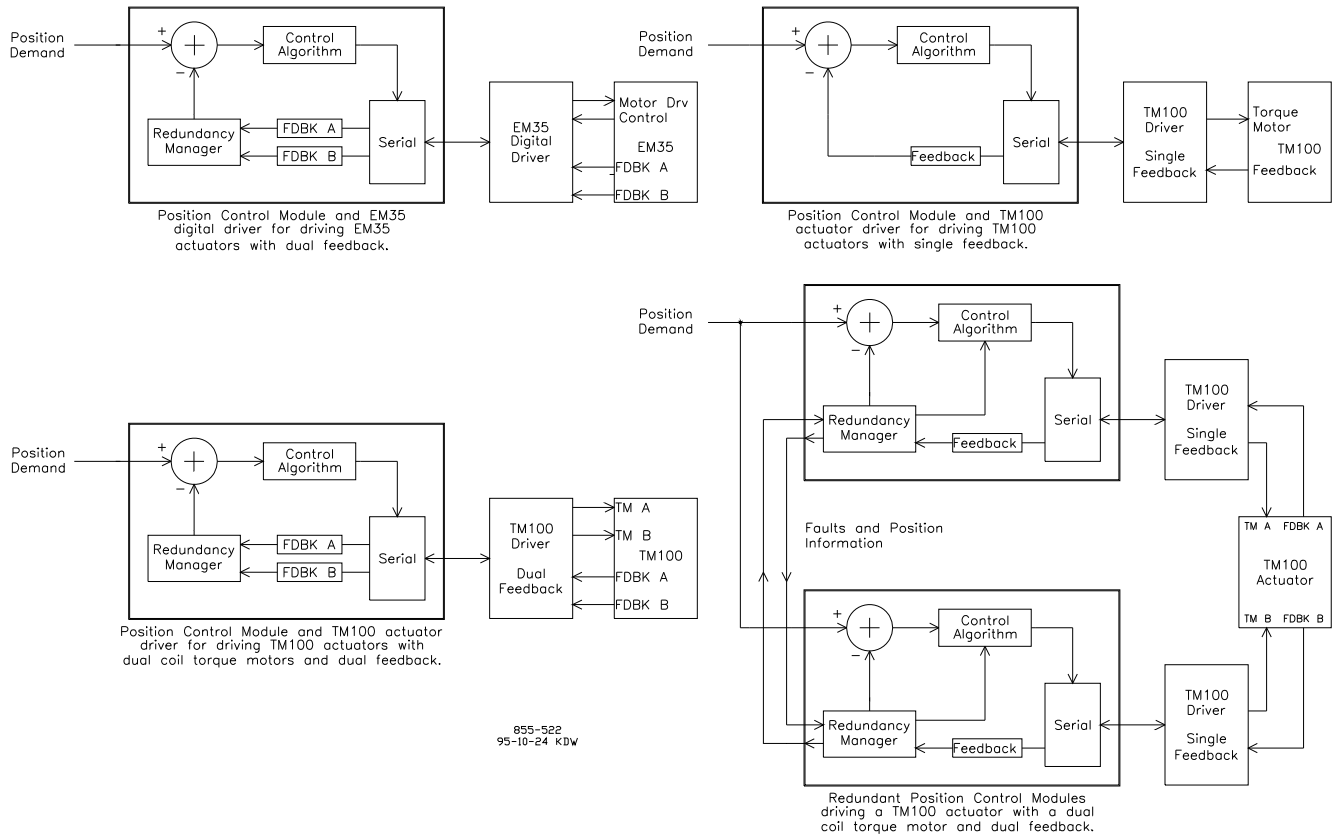

Figure 6-4. Position Control Module as used with various Remote Drivers

9.5.2—Module Specification

Controller Type: model-based
 Execution time: 1.67 ms
 Dither: Tunable amplitude, 50% duty cycle
 Frequency: 40 Hz with TM100 DFB and EM35 drivers, 25 Hz with TM100 SFB

Communications

Type: Synchronous
 Interface: RS-485
 Data length: 16 bits +1 bit parity
 Error detection: Odd parity
 PCM Detectable Faults Parity: Shutdown if parity error exist four consecutive times
 Feedback: Shutdown if feedback angle > 90°
 Position error: Alarm if feedback differs from demand by tunable amount for tunable delay
 Null fault: Alarm if null current moves outside settable limits
 (TM100 drivers only)

Fdbk spread fault: Alarm if feedback signals differ by settable amount. Control from higher/lower feedback selectable.

9.5.3—Installation

The modules slide into card guides in the control's chassis and plug into the motherboard. The modules are held in place by two screws, one at the top and one at the bottom of the front panel. Also at the top and bottom of the module are two handles which, when toggled (pushed outward), move the modules out just far enough for the boards to disengage the motherboard connectors.

9.5.4—FTM Reference

See Chapter 12 for complete field wiring information for the EM/TM Position Control Module FTM. See Appendix A for part number cross reference for modules, FTMs, and cables.

9.5.5—Troubleshooting

Following being reset, the PCM will perform a series of self-tests. The PCM will also check for run-time errors. This includes checking for the presence of the Minor Frame Timer (MFT) signal along with insuring that proper communications exists between itself and the CPU. If a self-test has failed or if a run-time fault exists, the LED will blink according to the following chart:

Table 6-1. LED Indications of Failure

Error Type	Number of Blinks	Meaning
Self-test Errors	1	Internal register test failure
	2	RAM test failure—both bytes
	3	RAM test failure—high byte
	4	RAM test failure—low byte
	5	EPROM checksum error
	6	EEPROM read/write failure
	7	EEPROM checksum error
Run-time Errors	8	MFT signal absent > 200 ms
	9	Invalid command received
	10	Loss of communication with CPU

A fault LED that is constantly lit may indicate that the PCM did not get a proper reset or that it is unable to execute its program.

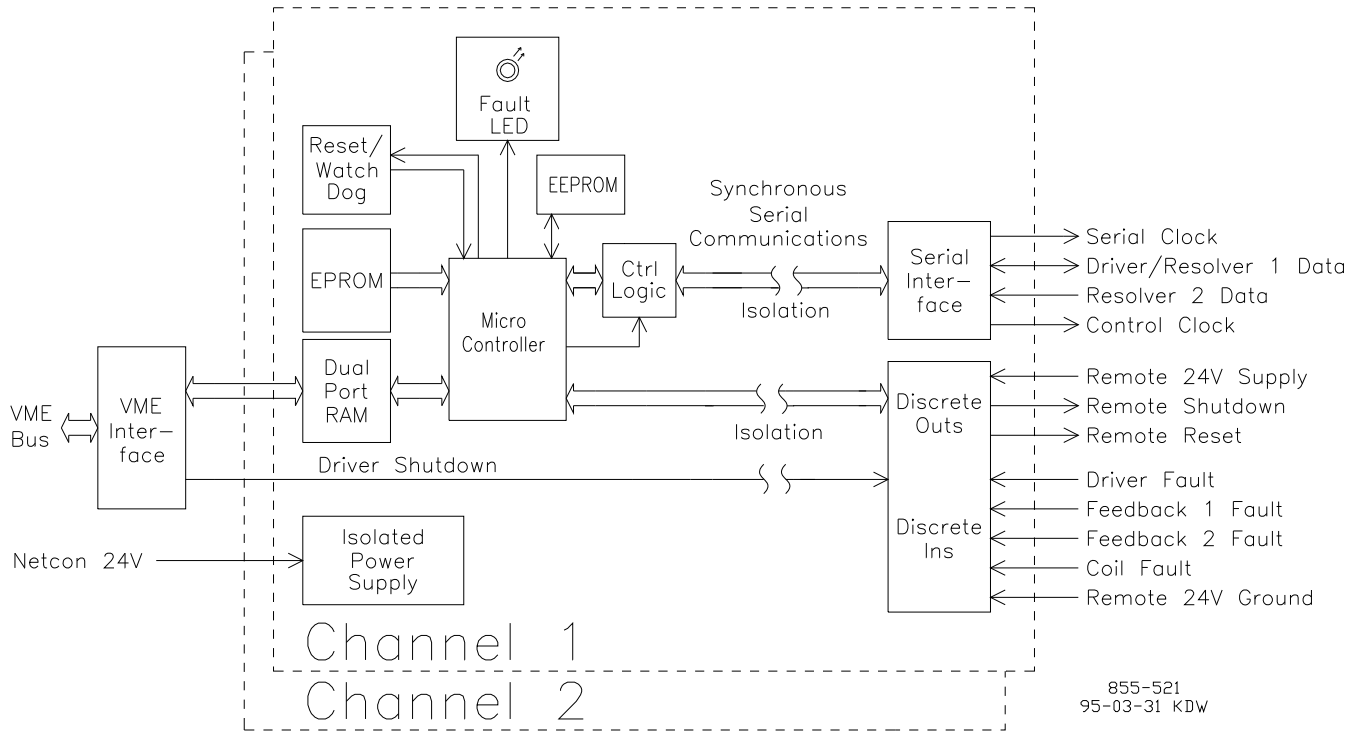

Figure 6-5. Position Controller Module Block Diagram

Chapter 7.

Field Termination Modules (FTMs)

7.1. Service Panel

The Service panel can be used by the system operator to communicate with a 040 CPU Module in a stand-alone MicroNet system (see Chapter 5 for MicroNet CPU module information and Appendix A for applicable module part number). The panel can be used to occasionally check the system, continuously monitor a value, or tune variables, (when applicable), through a 24-key keypad with a split-screen display. An optional mounting panel may be used to install the Service Panel in a 19 inch rack.

IMPORTANT

The Service Panel is used only with the 68040 CPU Module.



Figure 7-1. 68040 CPU Module Service Panel

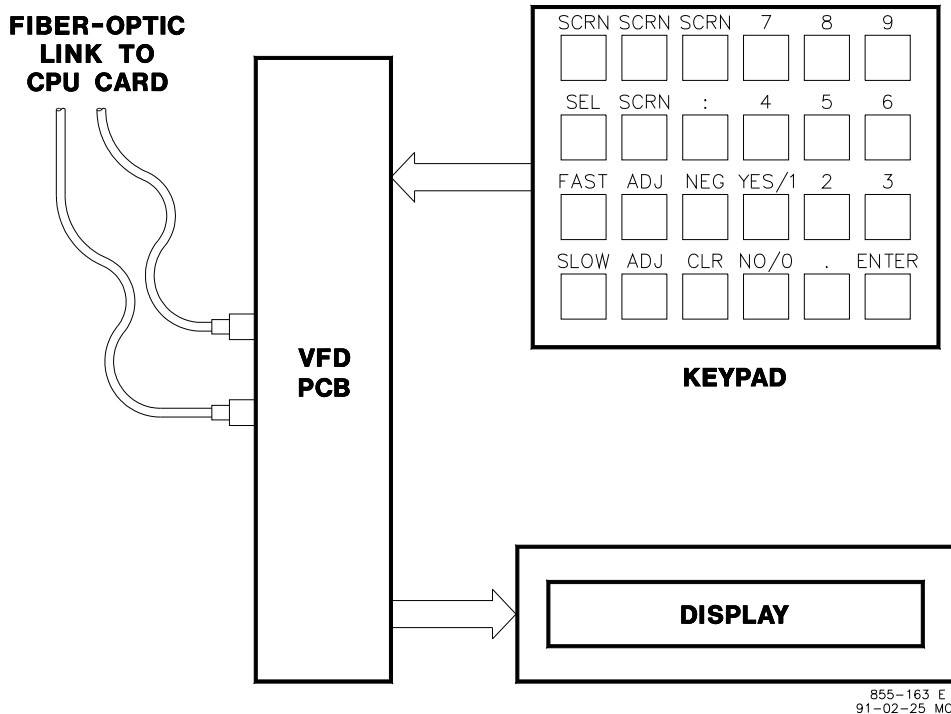

Figure 7-2. Service Panel Block Diagram

The VFD module communicates with the CPU through a twin fiber-optic cable. The fiber optic cables come in several different lengths. See Appendix A for part numbers and lengths.

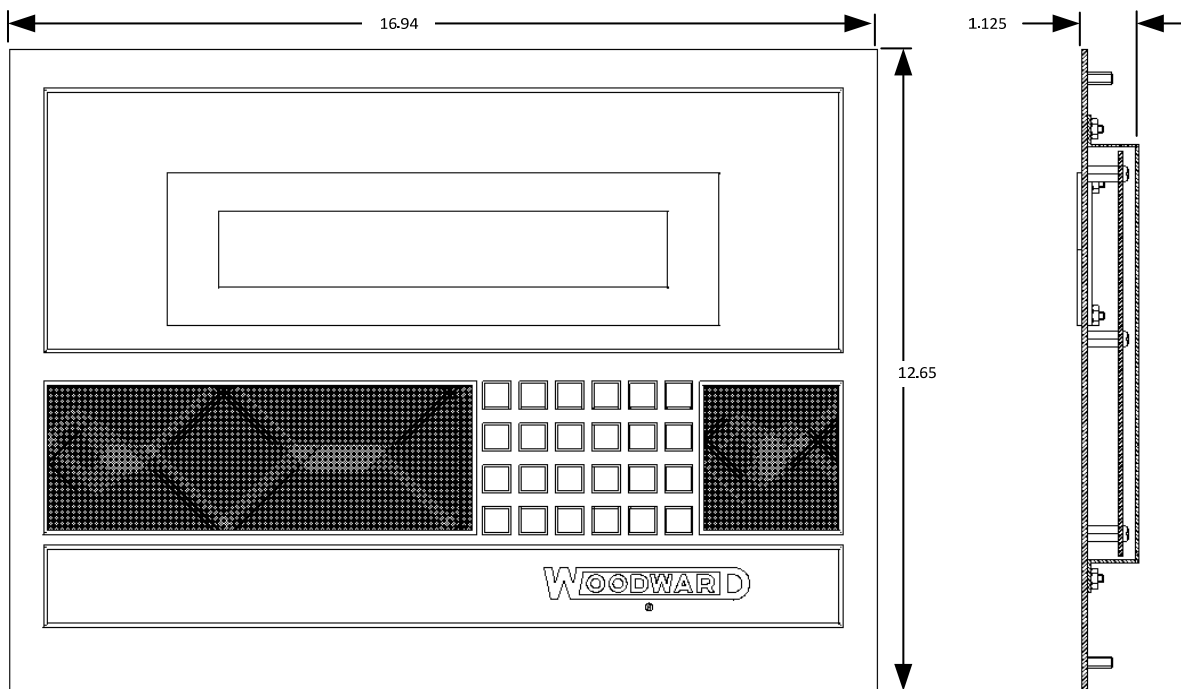

Figure 7-3. Service Panel Outline Dimensions

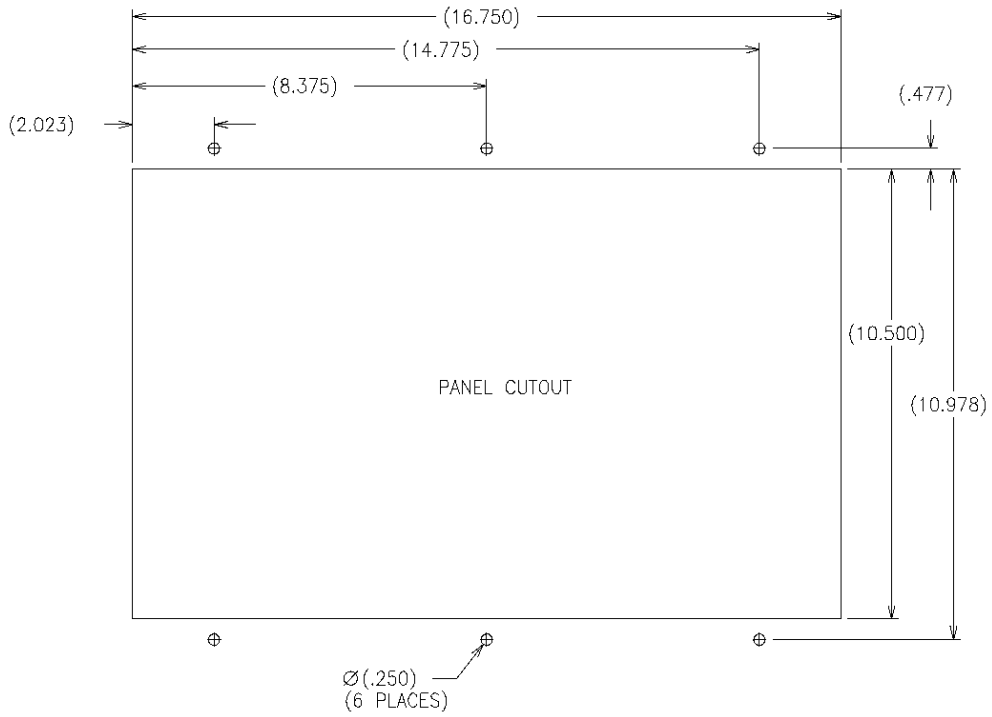

Figure 7-4. Service Panel Cutout Dimensions

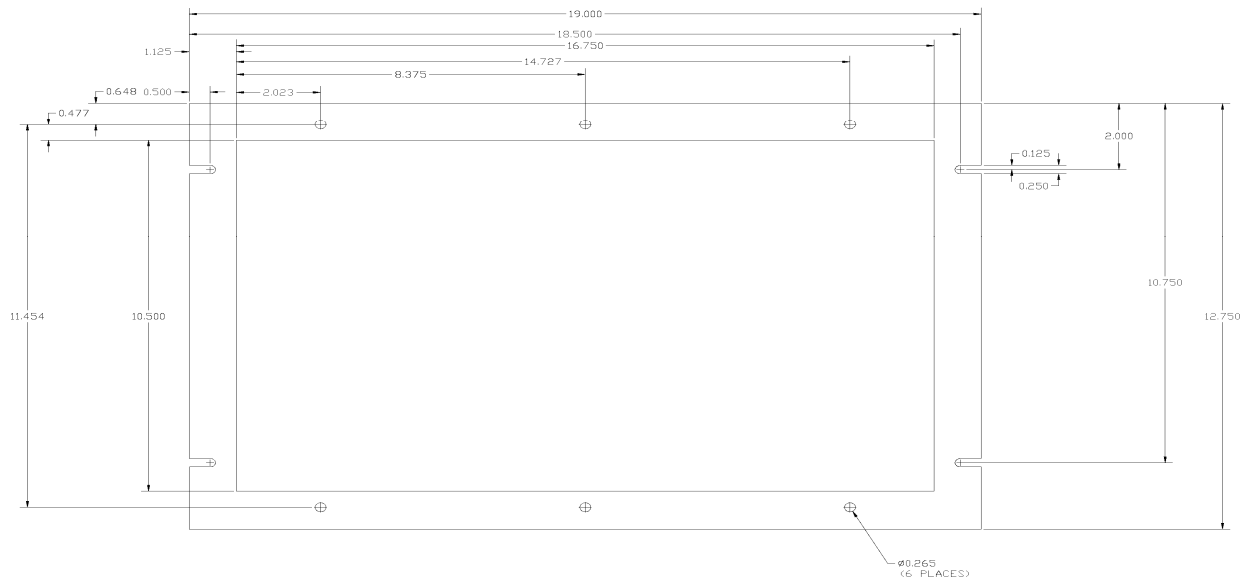

Figure 7-5. Service Panel Optional 19 Inch Mounting Panel

7.2. CPU Interfaces

7.2.1—Ethernet FTM

To ensure signal integrity and robust operation of Ethernet devices on the Pentium CPU module, an Ethernet FTM (Field Termination Module) is required when interfacing an Ethernet connection (see Appendix A for the Ethernet Isolation FTM part number). Its primary function is to implement EMI shielding and cable shield termination of the Ethernet cable. Along with this FTM, double shielded Ethernet cables (SSTP) are required for customer installations. This FTM should be installed between the CPU Ethernet connection and your field network connection.



Figure 7-6. Ethernet Interface FTM

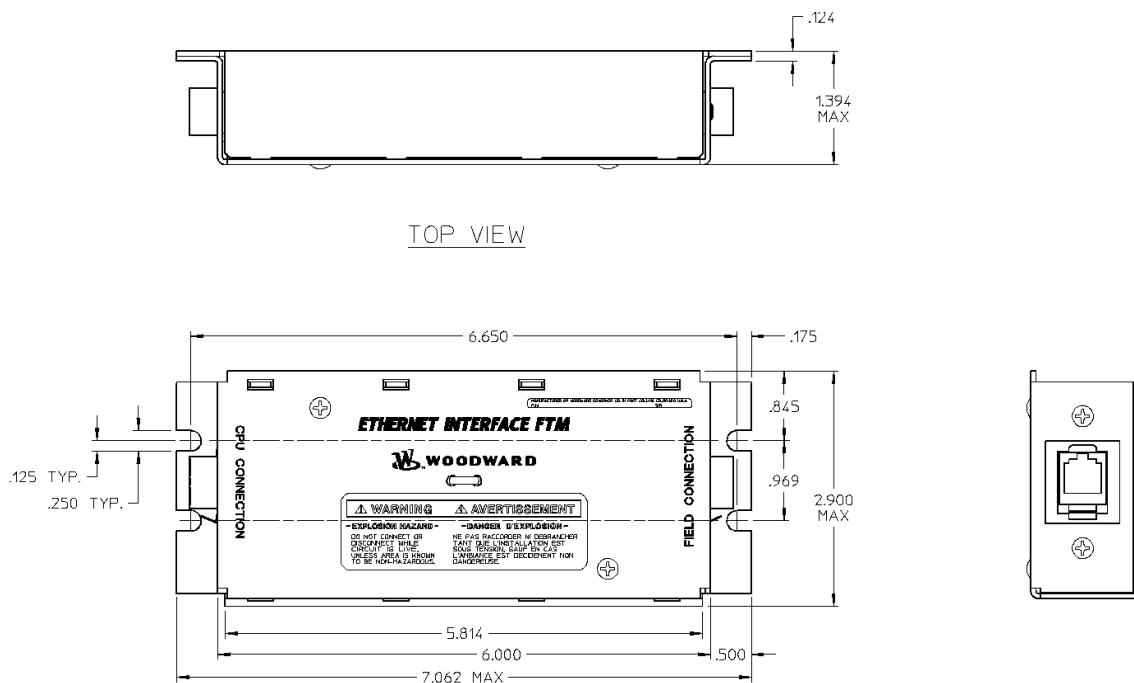

Figure 7-7. Ethernet Interface FTM Outline Drawing

7.2.2—CPU Serial Interface (RS-232-RS-232) FTM

IMPORTANT

A Serial Port Isolator/Converter must be properly installed, grounded, and powered prior to connection with the CPU. Once properly installed, it may be connected to a field device at any time. Alternatively, the isolator may be connected to the field device. However, it must be properly installed, grounded, and powered prior to connection to the CPU.

Additional hardware is required when an RS-232 serial port connection on either the MicroNet CPU (040) or (Pentium) module is needed (see Appendix A for the CPU Serial Interface (RS-232–RS-232) FTM part number). These communication ports are non-isolated. A shielded cable and Serial Port Isolator/Converter are required when using any of these ports to avoid susceptibility to EMI noise and ground loops related to PC connections and typical industrial environments. Depending on the CPU type, the hardware may include the following parts:

- 1 Ea Filter–RS-232 Db9mf
- 1 Ea Cable–10 ft. Molded Db9f to Db9f Null Modem w/thumbscrews
- 1 Ea Converter–Isolated RS-232–RS-232, Phoenix Contact, DIN Rail

Configure the parts for a 040 CPU as shown in Figure 13-55.

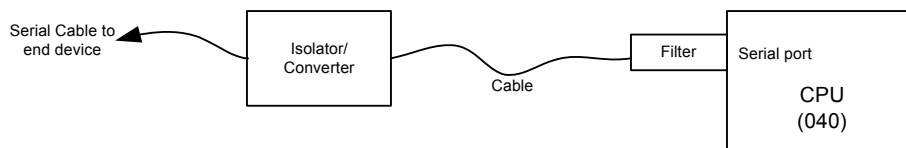

Figure 7-8. Kit Configuration (040 CPU)

7.2.3—CPU Serial Interface (RS-232-RS-232) FTM Marine Certified

IMPORTANT

A Serial Port Isolator/Converter must be properly installed, grounded, and powered prior to connection with the CPU. Once properly installed, it may be connected to a field device at any time. Alternatively, the isolator may be connected to the field device. However, it must be properly installed, grounded, and powered prior to connection to the CPU.

Additional hardware is required for Marine Certified applications when an RS-232 serial port connection on either the MicroNet CPU (040) or (Pentium) module is needed (see Appendix A for the CPU Serial Interface (RS-232–RS-232) FTM Marine Certified part number). Depending on the CPU type, the hardware may include the following parts:

- 1 Ea Filter–RS-232 Db9mf
- 1 Ea Cable–10 ft. Molded Db9f to Db9f Null Modem w/thumbscrews
- 1 Ea Converter–Isolated RS-232–RS-232, KD485, DIN Rail

See Volume 2, Figure 12-55, 040 CPU.

7.2.4—CPU Serial Interface (RS-232-RS-485) FTM

IMPORTANT

A Serial Port Isolator/Converter must be properly installed, grounded, and powered prior to connection with the CPU. Once properly installed, it may be connected to a field device at any time. Alternatively, the isolator may be connected to the field device. However, it must be properly installed, grounded, and powered prior to connection to the CPU.

Additional hardware is required when an RS-485 serial port connection on either the MicroNet CPU (040) or (Pentium) module is needed (see Appendix A for the CPU Serial Interface (RS-232–RS-485) FTM part number). Depending on the CPU type, the hardware may include the following parts:

- 1 Ea Filter–RS-232 Db9mf
- 1 Ea Cable–10 ft. Molded Db9f to Db9f Null Modem w/thumbscrews
- 1 Ea Converter–Interface (RS-232 to RS-485)

See Volume 2, Figure 12-55 for 040.

7.2.5—CPU Serial Interface (RS-232-RS-485) FTM Marine Certified

IMPORTANT

A Serial Port Isolator/Converter must be properly installed, grounded, and powered prior to connection with the CPU. Once properly installed, it may be connected to a field device at any time. Alternatively, the isolator may be connected to the field device. However, it must be properly installed, grounded, and powered prior to connection to the CPU.

Additional hardware is required for Marine Certified applications when an RS-485 serial port connection on either the MicroNet CPU (040) or (Pentium) module is needed (see Appendix A for the CPU Serial Interface (RS-232–RS-485) FTM Marine Certified part number). Depending on the CPU type, the addition hardware may include the following parts:

- 1 Ea Filter–RS-232 Db9mf
- 1 Ea Cable–10 ft. Molded Db9f to Db9f Null Modem w/thumbscrews
- 1 Ea Converter–Isolated RS-232–RS-422/RS-485, KD485, DIN Rail

See Volume 2, Figure 12-55 for 040 CPU.

We appreciate your comments about the content of our publications.

Send comments to: icinfo@woodward.com

Please reference publication **26167V3**.



PO Box 1519, Fort Collins CO 80522-1519, USA
1041 Woodward Way, Fort Collins CO 80524, USA
Phone +1 (970) 482-5811

Email and Website—www.woodward.com

Woodward has company-owned plants, subsidiaries, and branches,
as well as authorized distributors and other authorized service and sales facilities throughout the world.

Complete address / phone / fax / email information for all locations is available on our website.