

Users manual

Temperature Monitoring Unit **TS-01**



1 Technical data	1
2 Block diagram	2
3 Technical Description	3
3.1 General.....	3
3.2 "PWR" Measuring Circuit.....	3
3.3 "temp >" Measuring Circuit.....	4
3.4 "temp >>" Measuring Circuit.....	4
4 Connections	4
4.1 Inputs	4
4.2 Outputs.....	4
4.3 Installation Instructions	5

1 Technical data

Power supply:	24V - 270V \pm 10% DC 40V - 270V \pm 10%, AC 50-60Hz
Power input:	< 6VA or < 6W
PTC thermistor connection	2-wire connection relay closing 3.0 k Ω < R _{ON} < 3.2 k Ω relay opening 1.4 k Ω < R _{OFF} < 1.6 k Ω
3-relays	Max. voltage 230V Max. current 6A Max. switching capacity AC 1500 VA DC 120 W Re1: Power supply OK (green LED) Re2: PTC thermistor connection temp. > triggered (yellow LED) Re3: PTC thermistor connection temp. >> tripped (red LED)
Ambient temperature:	-10 ... +50°C
Connection data:	Rigid wire 0.2 – 2.5 mm ² Stranded wire 0.2 – 2.5 mm ²
Dimensions:	W x H x D 45mm x 99mm x 114.5 mm
Mounting:	Snap-on mounting for symmetrical mounting rail (35mm standard rail)

2 Block diagram

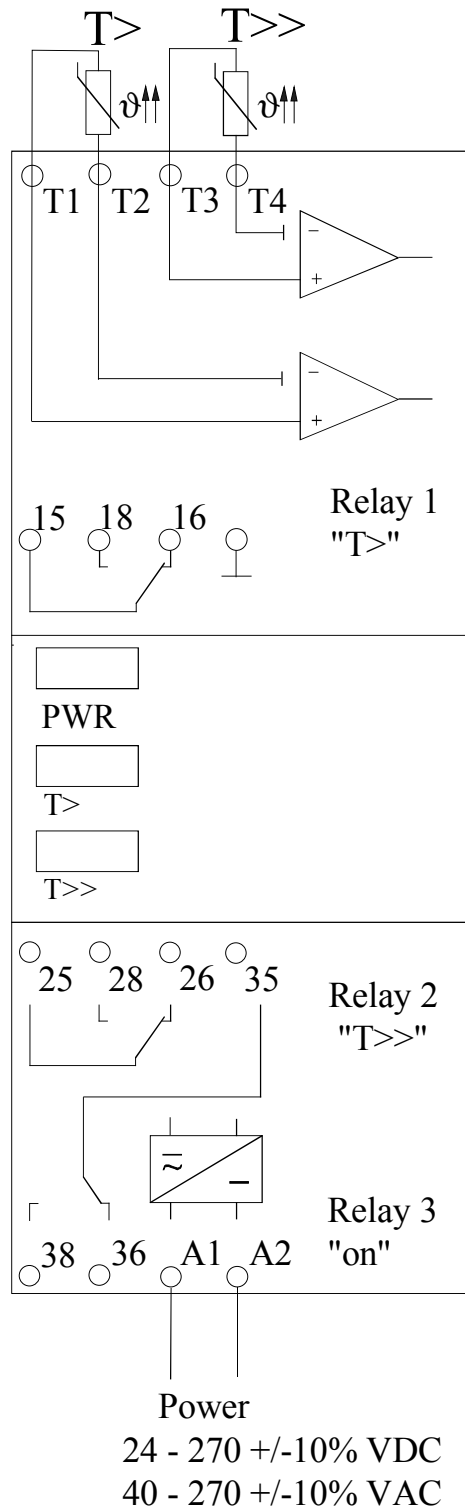

3 Technical description

3.1 General

The TS-01 temperature control unit is used to monitor the temperature of equipment by means of PTCs in accordance with DIN 44081/82 or DIN VDE 0660 Part 303.

Attached is an example of temperature monitoring of a transformer used for energy distribution in the field of medium- and high-voltage systems.

Three relays, are assigned to different measuring circuits. The significance of the individual measuring circuits and the LEDs can be found in the following sections.

The PTC thermistors are to be designed in such a way that the threshold temperature of the PTCs in the "temp. >" circuit is lower than that of the PTCs in the "temp. >>" circuit.

Example:

"temp. >" threshold temperature	T1 = 120°C
"temp. >>" threshold temperature	T2 = 150°C

Based on the hysteresis behaviour of the PTC thermistors, the threshold " on " temperature for the relays is slightly higher than the threshold " off " temperature.

As the operating point of the measuring circuits is in the $k\Omega$ range and the resistance of a PTC thermistor is only a few hundred Ohm (when operated below the threshold temperature), several PTC's can be connected in series (max. resistance < 1.4 kOhm).

3.2 "PWR" Measuring Circuit

Relay 3 is used to monitor the supply voltage. If the necessary operating voltage is applied to the measuring circuit, the relay picks up and the green LED (*PWR*) lights. A changeover contact is available as an output (terminals 35,38,36).

In case of power failure, Relay 3 drops, as well as relays Relay1 and 2, independent of their previous position. The relays are in the position as shown in chapter 4.1 and 4.2.

By power return, Relay 3 , energizes, the position of Relays 1 and 2 is depending of the value of the connected PTCs.

3.3 "temp. >" Measuring Circuit

If the threshold temperature of the PTC thermistor (f.ex. $T_1 = 120^{\circ}\text{C}$) is exceeded, Relay 1 picks up and the yellow LED ($T >$) lights. A changeover contact is available for output (terminals 15, 18, 16). If the temperature decreases below the threshold, the relay drops out and the LED extinguishes.

3.4 "temp. >>" Measuring Circuit

If the threshold temperature of the PTC thermistor (f.ex. $T_1 = 150^{\circ}\text{C}$) is exceeded, Relay 2 picks up and the red LED ($T >>$) lights. A changeover contact is available for output (terminals 25,28,26). If the temperature decreases below the threshold, the relay drops out and the LED extinguishes.

4 Connections

4.1 Inputs

Terminal marking	Connection
T1, T2	PTC temp.> *
T3, T4	PTC temp.>> *
A1, (L / +); A2, (N / -)	24 - 270V $\pm 10\%$ DC, 40 - 270V $\pm 10\%$ AC / 50 - 60Hz

* Standard value for PTC circuits: $R_{\text{series}} < 1.4 \text{ k}\Omega \rightarrow$ see also section 4.3 Installation instructions

4.2 Outputs

Terminal marking	Connection
15,18,16	Changeover contact temp. > (Relay 1)
25,28,26	Changeover contact temp. >> (Relay 2)
35,38,36	Changeover contact PWR/ON (Relay 3)

x5 = Common contact
x6 = NC contact
x8 = NO contact

4.3 Installation instructions

PTC > and PTC >>

Connection variants	Action
2-wire connection	Remove premounted 1 kΩ resistors, connect PTC> to terminal T1/T2 and PTC>> to terminal T3/T4 (both protected against polarity reversal)
No PTC> connection	Leave mounted resistor connected to terminal T1/T2
No PTC>> connection	Leave mounted resistor connected to terminal T3/T4

Connection to power supply

Do not connect the power cable until the sensor cables have been secured!
The system connection is protected against polarity reversal (for AC and DC supply).
The TS-01 is without PE connection and only has terminals for L/+ and N/-.
A PE conductor however can be connected to the ⊥ terminal for the PTC probes.
The power supply unit is isolated from the measuring circuits.

Permitted resistance ranges for PTC circuits T> and T>>

The PTC circuit may consist of both a single PTC or a PTC connected in series. In this case, to ensure flawless operation of the TS-01 temperature monitoring unit, the resistances values in the following table below should be observed in all cases to guarantee proper operation of the TS-01 temperature monitoring

In the case of series connection, the total resistance of the PTC chain should be $\rightarrow R_{\text{series}} < 1.4 \text{ k}\Omega$.

Function	Resistance range
Fault recognition, short circuit	0 Ω – 15 Ω
Measuring range of PTC	50 Ω – 50 kΩ
Fault recognition, open circuit	100 kΩ – ∞

The standard value of a PTC in accordance with DIN 44081/82 or DIN VDE 0660 Part 303 is $\leq 250\Omega$ within the range of -20°C to TNF-20K and $\geq 4000\Omega$ at TNF+15K. The resistance of the PTC's has to within these limits (TNF is the designated reaction temperature of a PTC).